

DW-GR LCD Autoclave User Manual



Please read operating manual before installation and operation.

Drawell International Technology Limited

Chongqing Drawell Instrument Co., Ltd.

Shanghai Drawell Scientific Instrument Co.,Ltd.

Address : Suite 2204,Building No.11,Shiyou Road No.1, Yuzhong District,
Chongqing China.

Homepage : www.drawell.com.cn

Tel : 0086-023-63268643

Email : sales05@drawell.com.cn



Precaution on Safe Operation



Precautions:

- Do not open/close the cover forcibly before energization.
- Do not disassemble/reassemble the instrument without authorization. If repairs or services are needed, please contact your local dealer or manufacturer service to dispatch qualified and certified maintenance technicians.
- Never use the autoclave to sterilize corrosive products such as acids, bases, and phenols, volatile compounds, solutions of ethyl alcohol, methyl alcohol, chloroforms, and the like, or radioactive substances.
- Never use the standard configuration of the instrument to sterilize liquid items contained in airtight glass bottles or other airtight glass vessels, as changes in temperature and pressure during the operation may cause these bottles to burst.
- Do not use the instrument to cook food.
- Do not use the instrument for purposes other than sterilization, drying, and agar melting, or for sterilization of flammable, explosive, and oxidizable substances as well as strong acids, strong bases, saline water, and the like; otherwise, it may lead to corrosion of the sterilization chamber and pipeline, or even an explosion.
- Do not block the steam exhaust port on the safety valve, as this may prevent the safety valve from discharging steam and relieving pressure in the event of an abnormality.
- Make sure the pressure gauge reads “0 MPa” before opening the chamber cover; when the pressure in the sterilization chamber is higher than “0 MPa”, do not open the chamber cover or the drain valve, otherwise it can lead to personal injuries due to high-pressure steam spraying.
- When adding purified or demineralized water into the sterilization chamber, do not let any water

leak into the control circuit, which may cause electric shock or other malfunctions.

- When using cleaning bags, waste bags, or other bags, place them in the stainless steel basket first, and then put the basket into the sterilization chamber, otherwise it may affect the precision of temperature.
- Keep an eye on the temperature inside the sterilization chamber, which is high at the end of an operation cycle. When opening the cover, keep your face and hands away from the sterilization chamber to avoid being scalded by the spraying steam; and when taking items out of the sterilization chamber, be sure to wear heat-insulating gloves. Since it takes time for high-temperature liquids to cool down, when taking sterilized liquid substances out of the sterilization chamber, ensure that they are sufficiently cooled to avoid scalding.
- Make sure to use purified or demineralized water as sterilization water to avoid affecting the service life of the autoclave. When the instrument continues to work, allow it to cool down for at least 15 minutes. Otherwise, the instrument will fail to produce enough saturated steam.
- If an abnormal condition (such as abnormal sound, odor, and smoke) occurs, turn off the power immediately, pay attention to the instrument, and contact local DEALER OR MANUFACTURER service.
- Always place a chemical indicator card for pressure steam sterilization (hereinafter referred to as the "chemical indicator card") that is suitable for the sterilization temperature on the items to be sterilized during each sterilization cycle. After the items have gone through a complete sterilization cycle, if the color change on the chemical indicator card matches the corresponding temperature and duration, it indicates that the required temperature and duration for sterilization have been met. Otherwise, if the color change does not match, it means the sterilization requirements have not been fulfilled.

Content

Chapter 1 About the Instrument.....	4
Chapter 2 Installation of Autoclave.....	11
Chapter 3 Operation Instruction.....	13
1.Basic sterilization illustration&operation instruction.....	14
1.Turn on the power.....	14
2.Open the sterilization chamber lid.....	14
3.Water adding.....	14
4.Load the articles to be sterilized.....	17
5.Close the sterilizer chamber lid.....	18
6.Select/Set the sterilization program.....	18
7.Start to sterilize.....	26
8.Cycle finished&Open the lid.....	26
9.Take out the sterilized articles.....	27
10.Turn off the power.....	27
2.Creating, modifying, deleting the program	28
1.Creating and modifying the program.....	28
2.Deleting program.....	28
3.Setting the sterilizing time.....	28
4.Setting of administrator menu.....	29
3.Clock checking and calibration	33
4.Setting auto start timer.....	34
5.Account management.....	35
Chapter 4 Maintenance.....	40
1.Cleaning.....	40
2.Parts maintenance.....	40
Chapter 5 Trouble shooting.....	44

Chapter 1 About the Instrument

1. Application

- This series of products are used for sterilization of scientific research institutions, laboratory utensils, culture media and unsealed liquids or preparations. Machine working only with power on.

2. Sterilization principle

- Steam is used as sterilization factor to kill loaded microorganisms. The main technical parameters of sterilization, such as pressure, temperature and time, are set and controlled by the program.

3.Types of microorganisms killed

- Using hot and humid high pressure steam as sterilization factor to kill loaded microorganisms, including spores of bacteria, spores of fungi, etc.

4. Product structure.

It is mainly composed of shell, sterilization chamber, sterilization door, built-in steam generator, pipeline system, temperature control system, pressure detection, safety interlock protection device and so on. The specification is preset and carried out automatically.

5.Normal working conditions

- Ambient temperature: 5 °C~ 40 °C
- relative humidity not greater than 85%.
- Atmospheric pressure: 70kPa~106kPa.
- Suitable for power supply AC200-240V, (50 -60) Hz.

6. Transportation requirement

Instruments are not allowed to stand upside down, overlap, below is not allowed to put items, avoid rain, carefully handle, there should be anti-movement measures.

7. Storage requirement

- Ambient temperature:-20 °C~ 55 °C.
- Relative humidity not greater than 93%.
- An indoor or sheltered place free of corrosive gas and well ventilated

8. Service life

- It is recommended to use up to 8 years

9. Technical specifications

Model	DW-GR60DA	DW-GR85DA	DW-GR110DA
Dimension(L*W*H,mm)	644mmX660mmX980	644mmX660mmX980	644mmX660mmX1180
Net weight	123kg	128kg	138kg
Model	DW-GR60DF	DW-GR85DF	DW-GR110DF
Dimension(L*W*H,mm)	644mmX831mmX980	644mmX831mmX980	644mmX831mmX1180
Net weight	126kg	130kg	137kg
Model	DW-GR60DR	DW-GR85DR	DW-GR110DR
Dimension(L*W*H,mm)	644mmX831mmX980	644mmX831mmX980	644mmX831mmX1180
Net weight	130kg	135kg	146kg
Capacity(L)	60L	85L	110L
Chamber dimension(Dia*H,mm)	φ390mm x505mm	φ390mm X 700mm	φ390mmX895mm
Power requirement	220V±10% 15A	220V±10% 25A	220V±10% 25A
Rated power	2900W	4600W	4600W
Chamber material	SUS304		
Sterilizing temperature	105°C~138°C		
Sterilizing time range	1min~6000min		
Melting temperature	60°C~115°C		
Metling time range	1min~6000min		

Warming temperature	45°C~79°C
Warming time range	1min~9999min
Drying time range	1min~300min
Cooling lock open	Solid/agar 40°C~99°C, Liquid 40°C~80°C
Exhaust level	0-5 Levels adjustable
Water tank	Yes
Auto Startup Timer	0~15days
Pressure	MAWP/Design pressure: 0.3MPa
Sterilizing mode	Liquid mode Liquid with warming mode Solid mode Wrapped instrument mode Fabric mode Rubber mode Fast mode Waste mode Agar mode Self-defined mode Drying mode(Only for GR-DR)
Controller	“Inspiration II”fast speed microcomputer controller
Safety device	Self-induction pressure interlocking device, lid closing checking, over temperature protection, temperature monitor, dry scorch protection system, over pressure protection,safety valve,over current and short circuit protection, leakage protection device,anti-scald safety protection, cooling lock, automatic troubleshooting system
Standard spare parts	Stainless steel baskets,water plate,waste water bottle
Optional spare parts	Printer, printing set,load thermometer, , adjustable pin,automatic water

10.Appearance and Parts

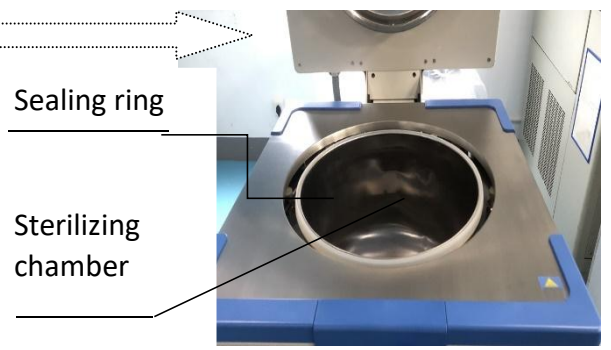
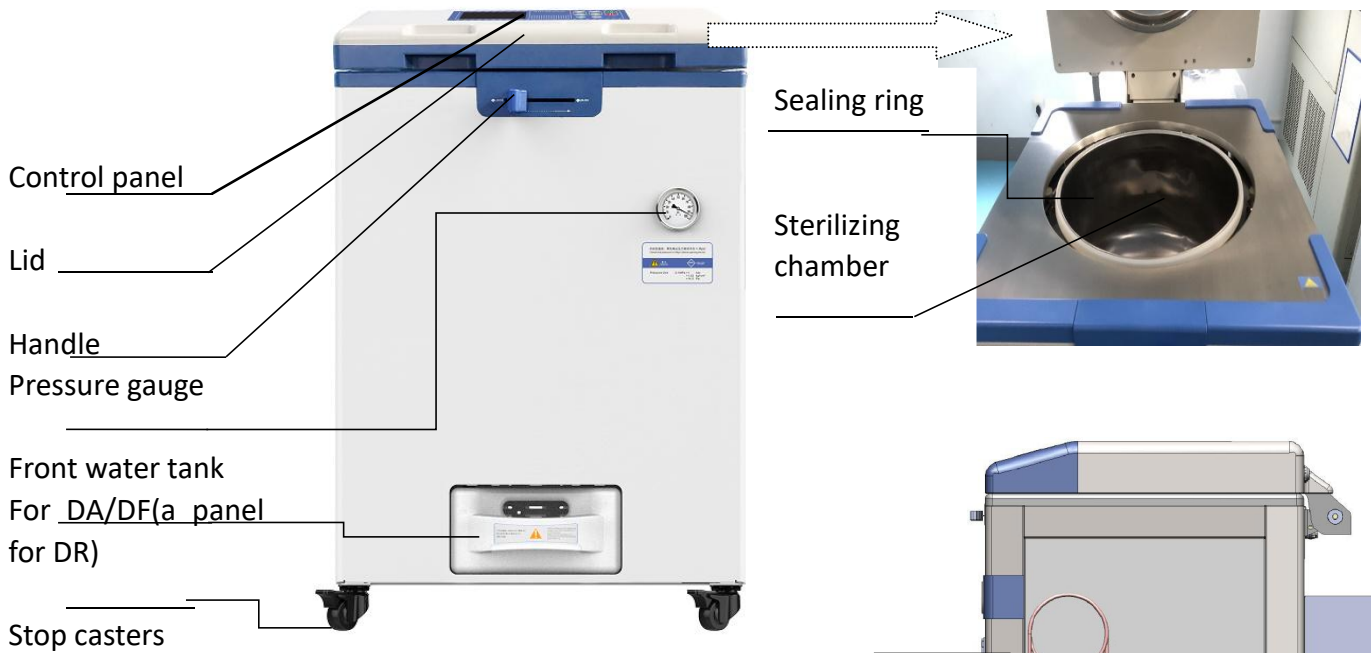

Water inlet silicone hose(only for GR-DF/DR)

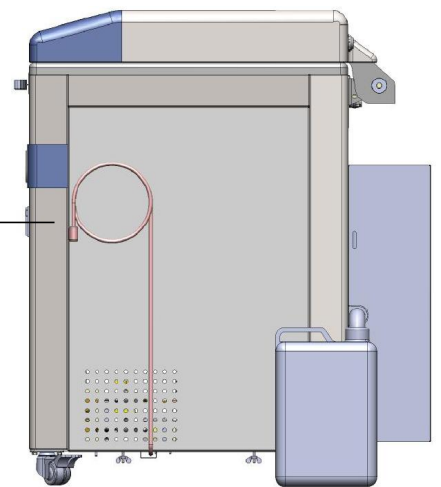

Right view

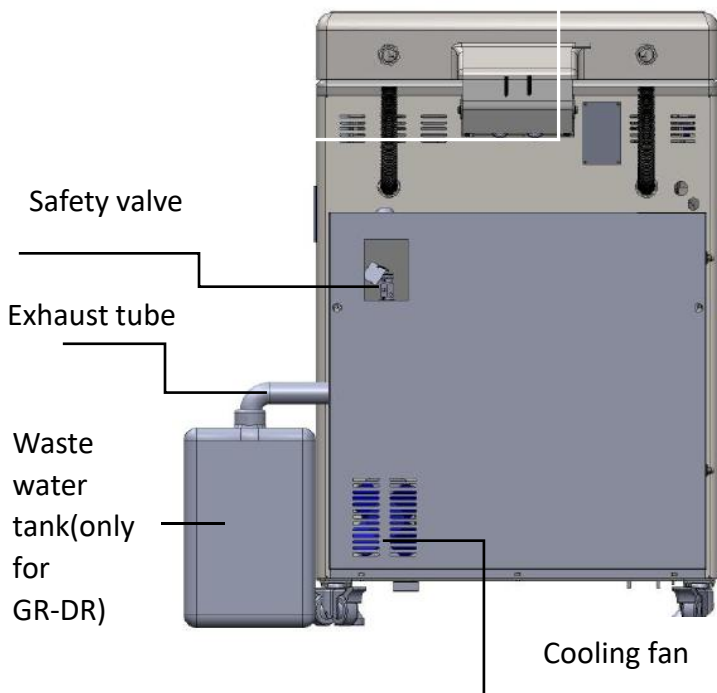

Back view

(The back water tank only for GR-DF/DR)

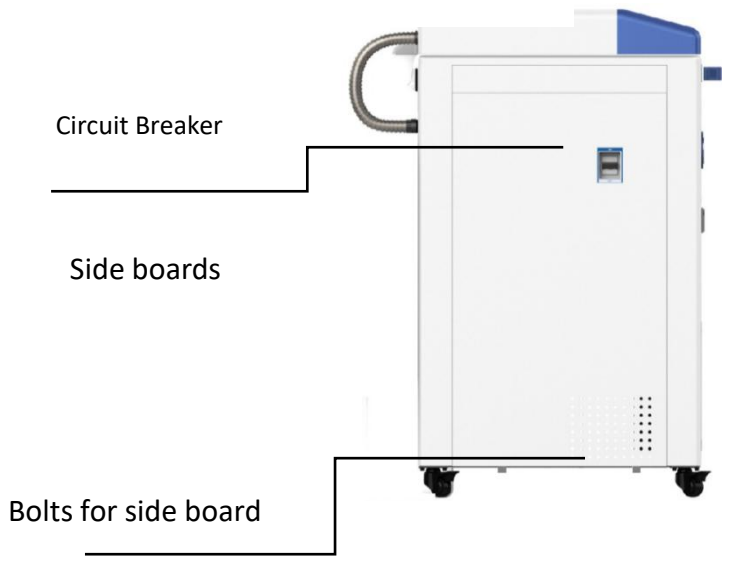

Left view

11.Parts Function

1、 Display Panel Function:

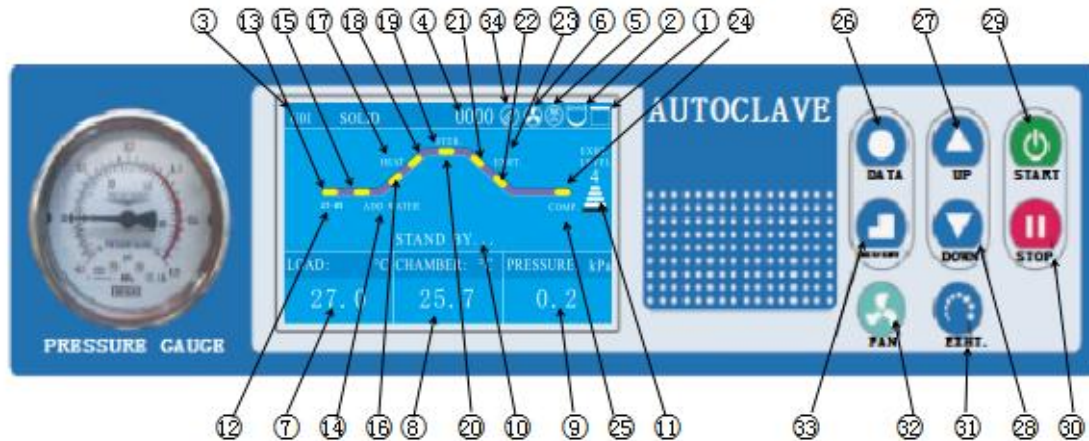

1.Lid interlocking icon:White when lid closed and locked, white and blinking when lid closed but not locked,red and blinking when lid is not closed.

2.Water level indicator icon:White when there is water in the chamber,red and blinking when lack of water.

Note:Available when there is automatic water feeding parts

3.Sterilization mode:Press UP/DOWN to choose the mode.

4.Ran cycle number:each time you press START,add 1 to the number.

5. Printer icon: this icon is available when the printer is selected. For more information on printer settings, see Chapter 4, "Setting of Administrator Menu."

6.Fan icon: when this function is on and when the chamber temperature is higher than 40 degrees, the fan icon will rotate and turn off automatically when the temperature is lower than 40 degrees. This function is default to be on.

7.Object temperature display:when this function is on, this area will show object temperature, when this function is off, here will show "---".

8.Chamber temperature display: displays chamber temperature

9.When the pressure sensor is installed and function is on, the current pressure value is displayed here, when this function is off, here will show "---".

10.The current status of the instrument: the working status of the current instrument is displayed here.

11.Exhaust level display: press "EXHT" key to adjust different exhaust level(volume), divided into 6 levels: Level 0 to level5, level 0 means no exhaust, level 5 means full exhaust.

12.ST-BY: ST-BY will flash under standby condition.

13.Standby state indicator: yellow means static state, when the flow chart is blue indicates that the instrument is in the standby state, when the flow chart is red indicates the machine is in the heating state.

- 14.ADD WATER: when running the program, if there is water in the chamber, the flow chart between "ST-BY" and "HEAT" state is displayed in red, means the standby state goes directly to the heating state. If there is no water, the "ST-BY" state will switch to the "ADD WATER" state, and the word "ADD WATER" will blink, indicating that the instrument is adding water, and the flow chart between "ST-BY" and "ADD-WATER" is red.
- 15.Flow chart light of ADD WATER
- 16.Heating indicator 1, when this indicator is red, means machine is heating up and temperature is between room temperature and boiling point temperature.
- 17.HEAT:when HEAT is blinking, means instrument is in heating process
- 18.Heating indicator 2, when this indicator is red, means machine is heating up and temperature is between boiling point temperature and sterilization temperature.
- 19.Sterilization state indicator:red means machine is in sterilization process
- 20.STER.:When blinking and flow chart of this part in red means during sterilizing process, the temperate is the set sterilizing temperature.
- 21.Exhaust indicator 1:When this indicator is red, means instrument is during exhaust process, the sterilization is finished, current temperature is cooling down, between set sterilization temperature and boiling point temperature.
- 22.Exhaust indicator 2:When this indicator is red, means instrument is during exhaust process, the sterilization is finished, current temperature is cooling down, betweenboiling point temperature and open lid temperature.
- 23.EXHT:When blinking and flow chart of this part in red means during exhaust process
- 24.Cycle end indicator:red means whole cycle ends
- 25.COMP.:blinks and whole flow chart is red, means the whole cycle completes.
- 26.DATA button,press DATA button can check the data of current program.When setting the parameter, you can press DATA to exit without saving the modification.
- 27.UP button,under standby condition,press UP button can switch from U01to U02,U03 to U03...;when modifying the parameter, press UP can increase value,long press this button, can increase the value by 10 units.
- 28.DWON button, under standby condition, press UP button can switch from U02to U01,U03 to U02...;when modifying the parameter, press UP can decrease value,long press this button, can decrease the value by 10 units.
- 29.START button,used to start the work(press over 2 seconds)
- 30.STOP button, used to stop the work(press over 2 seconds).When the machine is inserted with USB flash drive, and under standby condition,long press this button can remove the USB flash drive.
- 31.EXHT button, used to adjust the exhaust volume,during the liquid mode, be careful to set a lower exhaust volume to avoid liquid over-low.

32.FAN button,when this function is on, and chamber temperature is over 40°C , the cooling fan will start working automatically, press FAN button can stop or restart.Not valid when this function if off.

33.SET/ENT button,used to set data and confirm. 1)under standby condition,press SET/ENT to enter into administer menu;2)when input the password,press SET/ENT to input next number;3)When modifying the data, first time press SET/ENT to enter into modifying condition, second time press to save the modification.

34:USB icon:will appear when inserted with USB flash drive;will not store the data when there is power off or mis-remove the USB.

35. DRYING:when the DRYING is blinking, means it is during drying process.

36. Smart Cleaning:Under stand-by condition, hold UP+DOWN button together can start the smart cleaning function,then follow the screen instruction to do the smart cleaning job. If the screen show up the reminder for smart cleaning, if you want to perform it, please follow the screen instruction to add water, wait for the cleaning done by itself, and drain the water when the screen asks for. If you have added with one touch drainage function, press EXHT to start, if you want to exit, press STOP to exit. But when the screen shows the cleaning/washing is on going, please do not press STOP to exit, if you already start cleaning and the cleaning is not complete, the machine will keep sending out reminder until you complete again. And after cleaning, if the machine asks for water drainage, please drain it.

2、Cooling lock function:

After sterilizing, while cooling down, normally the chamber is cooling down quicker than the articles inside (especially for liquid). So, the user may get burnt if the articles are still hot. To make sure safety, autoclave is equipt with cooling lock "OPEN"temperature function, you can set a safe lid "OPEN" temperature.

The lid can be opened only when the chamber temperature is lower the preset "OPEN" temperature. If the machine is installed with load thermometer, the lid can be opened only when the chamber temperature and the article temperature are both lower the preset "OPEN" temperature.

3. Checking Package

Check the package before opening, take a picture if there is any damage. Open the box from the bottom (do not open the top), take out like a hat (shaken by two people from two sides). After opening the package, check if there is any damage of the machine, report to distributor or manufacturer.

4. Cleaning

- 1) Switch on the leakage protection switch and turn on the power, and then open the cover of sterilizer chamber, and take out the protective foams from the chamber. Clean the chamber and put the water plate and stainless steel baskets in.
- 2) Clean the foam scraps inside the sterilizer chamber completely to avoid blocking the pipeline.

5. Setting of Local Altitude

Before shipping, the machine has been set for an elevation between 0-300m, if the local elevation is over 300m, please reset the altitude to make sure proper usage of the machine.

Chapter 3 Operation Instruction

1、 Basic Sterilization Illustration & Operation Instruction

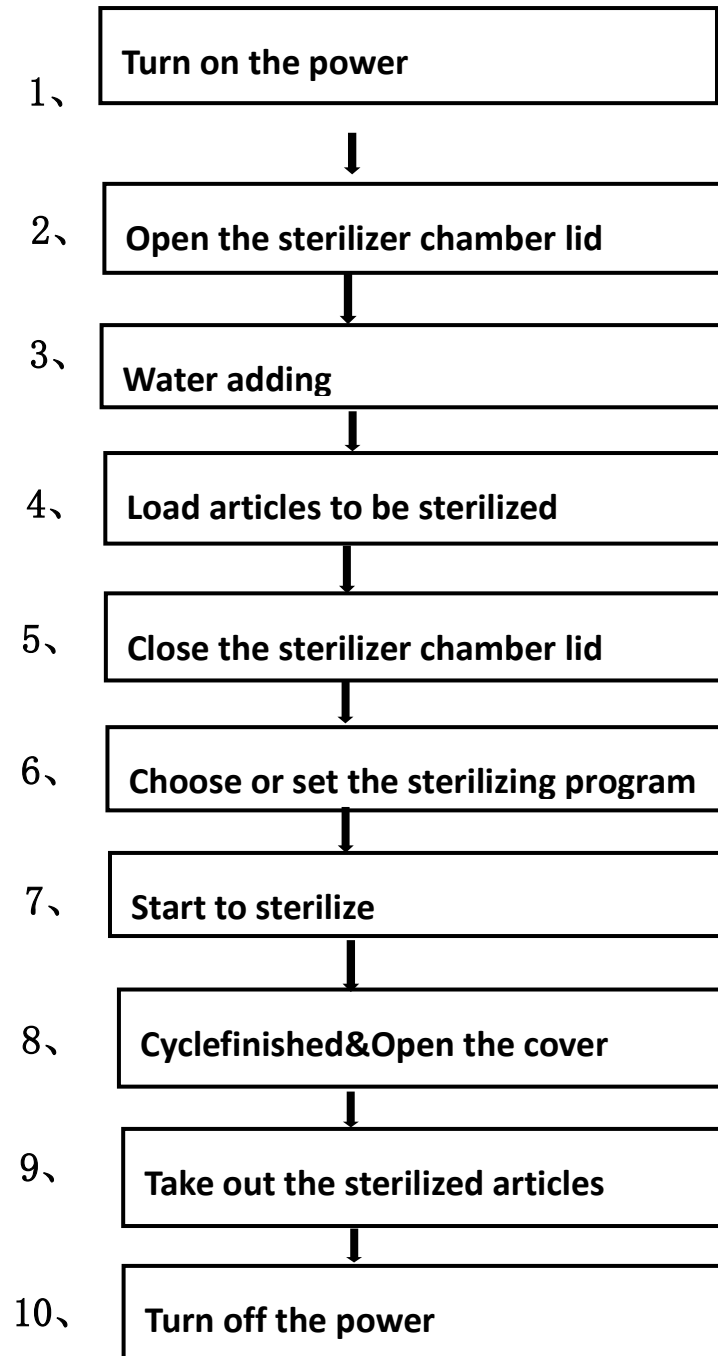

1. Turn on the power

- The system automatically performs self-check upon startup. After the self-check is completed, it will emit a prompt tone saying “Hello! Welcome to use our autoclave!”. Then, it will enter the last program screen saved by the user or display the last user login screen (when the Level 5 permission is enabled).
- When the instrument is in the standby state, if there is no operation within 30 min, the instrument will automatically enter the energy-saving mode and the screen will be closed; pressing any key will restore the display.

2. Open the sterilization chamber lid

- When opening the cover, gently press the middle front end of the upper cover with one hand, turn the opening/closing handle to the “UNLOCK” position with the other hand. Then,

the cover interlocking icon  will flash in red.

Grip the handle to open the chamber cover.

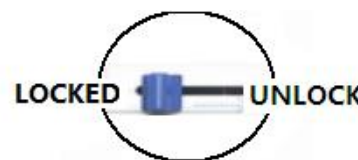

Note: 1) Gently open the chamber cover to prevent damage to the sealing ring. When operating the opening/closing handle, make sure the instrument is powered on and the power switch is in the ON position.

2) Take out the load promptly after the sterilization is completed, otherwise, it may cause negative pressure, thereby resulting in that the chamber cover cannot be opened.

3. Water adding

3.1 Adding water manually (For GR-DA)

- **Front water tank:** Drain the front water tank. If the condensate water is not promptly drained, it may overflow from the water filling funnel onto the floor.

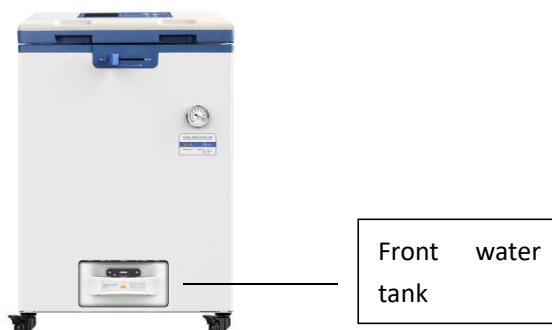

- **Manual water adding:** Open the lid, add water to the sterilization chamber from the top and ensure the water level is not higher than the surface of the water plate.

Maintain the water level sensor regularly, and replace the water in the sterilization

chamber and water inlet tank frequently to prevent dirt from adhering to the water level sensor and affecting its normal operation.

Note:  Do not open the sterilization chamber drain valve or water tank drain valve during sterilization, otherwise it may cause high temperature steam to spray out and hurt the operator.

- Always check the water level at the bottom of the chamber before each sterilization cycle since frequent water shortages can cause the electric heating tube to boil dry constantly, thereby accelerating its rust and aging, and reducing its service life.
- Always use purified or demineralized water (conductivity: 10~15us/cm) in the sterilization chamber, and do not use well water, saline water, or hard water, otherwise it may lead to corrosion and scaling of the sterilization chamber and shorten the service life of the heating element.

3.2 Adding water automatically (For GR-DF、GR-DR)

● Drain the water in the water tank:

For GR-DF, drain the front water tank.

For GR-DR, drain the 10L external water tank, if you want to do drying process later, connect the water tank on the right front side of the instrument to the exhaust pipe to collect water discharged after sterilization and before drying.

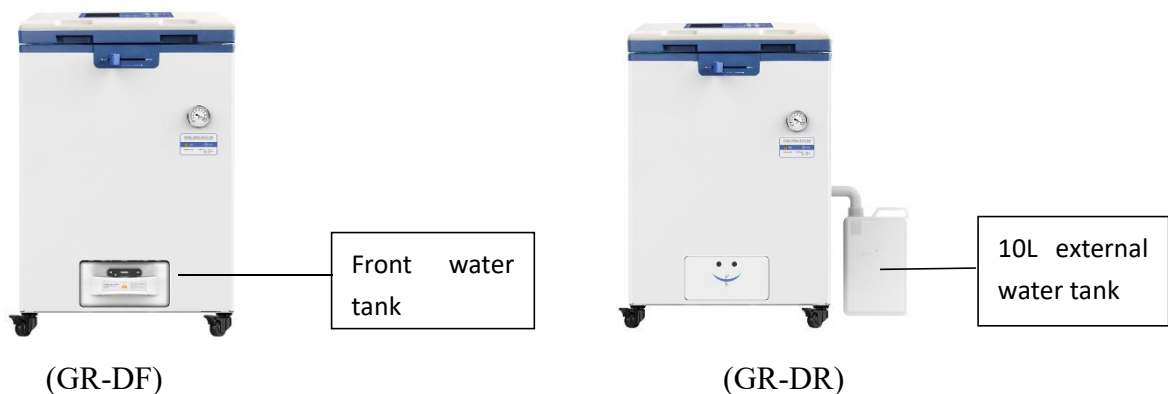

If the condensate water in the above water tank is not promptly drained, it may overflow to the floor.

Bring over a full pail (over 30L) of sterilizing water, put the silicon automatic water adding pipe into this pail, and follow the below screen instruction, water will be added into the back storage water tank (28L) and flow into the chamber automatic when you start the work.

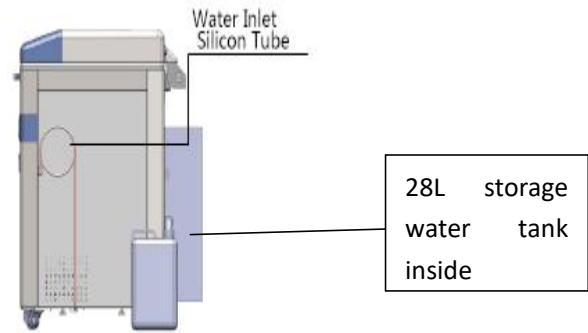

● If the water level of the back storage water tank drops below the LOW mark, a flashing icon “” will appear on the standby screen, and screen will jump to the below display:
Now press SET/ENT to start the autofill.

Lack of water in tank, start autofill now?

Yes: Press "SET/ENT"

NO: Press "DATA"

Note: 1. Please make sure that the source of water has been well connected with the instrument before pressing "SET/ENT"
2. The instrument will stop pumping automatically and prompt when the tank is full
3. You can press "STOP" to suspend during water adding, and press "STOP" again to continue
4. Water adding can be cancelled by pressing and holding "STOP" during the process

Then, the following screen appears:

Note:
1 The instrument will stop pumping automatically and prompt when the tank is full
2 You can press "STOP" to suspend during water adding, and press "STOP" again to continue
3 Water adding can be cancelled by pressing and holding "STOP" during the process.

● Maintain the water level sensor regularly, and replace the water in the sterilization

chamber and water inlet tank frequently to prevent dirt from adhering to the water level sensor and affecting its normal operation.

Note:  Do not open the sterilization chamber drain valve or water tank drain valve during sterilization, otherwise it may cause high temperature steam to spray out and hurt the operator.

- Always check the water level at the bottom of the chamber before each sterilization cycle since frequent water shortages can cause the electric heating tube to boil dry constantly, thereby accelerating its rust and aging, and reducing its service life.
- Always use purified or demineralized water (conductivity: 10~15us/cm) in the sterilization chamber, and do not use well water, saline water, or hard water, otherwise it may lead to corrosion and scaling of the sterilization chamber and shorten the service life of the heating element.

4、 Load articles to be sterilized

- Take the baskets out, and put the articles to be sterilized into the baskets
- Put the water plate first, then put the baskets on the waterplate, do not put the basket directly on the heater.

Notes: VERY IMPORTANT

1. Clean the articles to be put in thoroughly by cleaning agent and water
2. While putting the articles into the baskets, make sure the articles is placed well (overlap may cause inadequate sterilization). Put carbon steel devices and stainless steel device in different baskets and put several layer of Kapok paper under the carbon steel devices so as to protect the stainless baskets.
3. Sterile equipment should be packed with breathable packaging materials such as sterilization bags, sterile paper, gauze bags, etc.
4. When the sterilizer is loaded with plastic bags, the sterilization bags should be placed in the basket first and then in the sterilization chamber, otherwise the temperature control will be affected.
5. When the sterilizer is loaded with a cleaning bag, the opening of the cleaning bag shall be opened, and it shall be confirmed that the bag does not contact the inner wall of the sterilization chamber. During sterilization, if the bag mouth is sealed, the sterilization will be insufficient. If the bag is jammed into the sterilization chamber and the steam cannot fill every corner, the sterilization will be incomplete.

6. When sterilizing glassware such as beakers, conical bottles and test tubes, the glassware shall be placed upside down or horizontally. If the vessel can only be placed directly, a small amount of distilled water or purified water can be put into the sterilized vessel.
7. When sterilizing the liquid, such as chemical reagent or solvent, pay attention to the rationality of the liquid in the container (the volume of the flask shall not exceed 3 / 4, and the volume of the test tube shall not exceed 1 / 2), so as to avoid the liquid overflowing from the container during the process of heating or cooling. Before sterilizing, the cover of the container shall be loosened so as to ventilate, otherwise the container will be broken.
8. When agar is dissolved, the volume of the container should be less than 2 L, otherwise the dissolution will be insufficient. (Note: the Durham test tube with a diameter of more than 6mm shall be used as the sample tube. When the diameter of the sample tube is less than 6 mm, bubbles will remain in the tube, which will affect the sterilization effect).
9. If equipped with load thermometer, please put it in a place not easy to get damaged.

5、 Close the sterilizer chamber lid

- Press the middle part of the front end of the chamber cover gently, push the cover opening / closing handle to the left to the locked position, the system will give a sound, and the lid closing indicator light on the screen will become white.

Note:

- Before closing the cover, check if there are objects in or on the sealing ring, clean it to avoid damaging the sealing ring that may cause the steam leakage.
- Only when the lid close icon on the screen changes to white and not blinking, the machine will start to work.

6. Select/Set the sterilization program

(1) Selection method:

In the standby state as shown below, for symbols U01/U02...means the current program number, you can press UP and Down button to go to previous or next program. If you are happy with the current program, press START for 2 seconds to start the cycle.

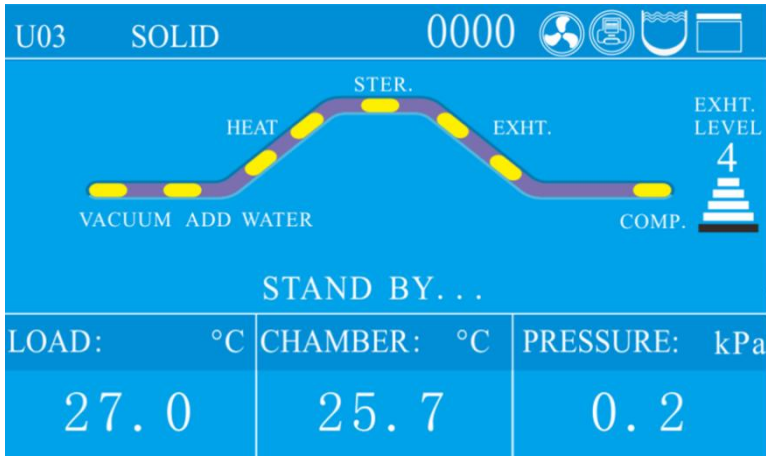

(2) Set the program

If you want to change program, under standby Press SET/ENT button to set the program.



When choose the program, if the current program is default program, you can choose the items to be sterilized first like below by UP/DOWN and SET/ENT:



If the program is not a default program, the screen will show below words:

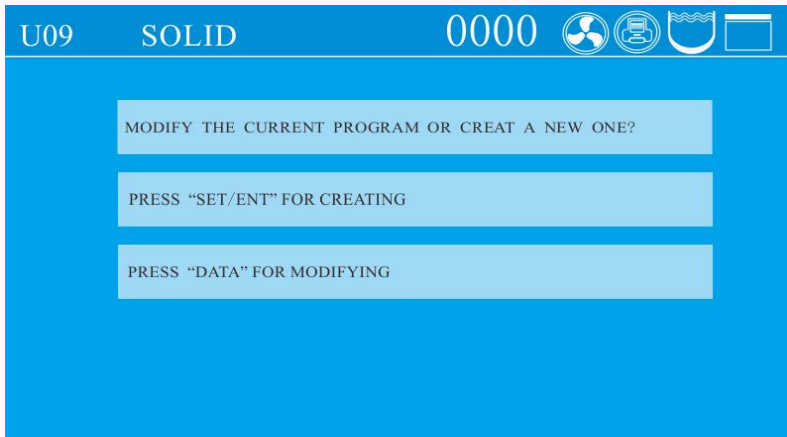

After the above setting, the screen will dump to below screen:

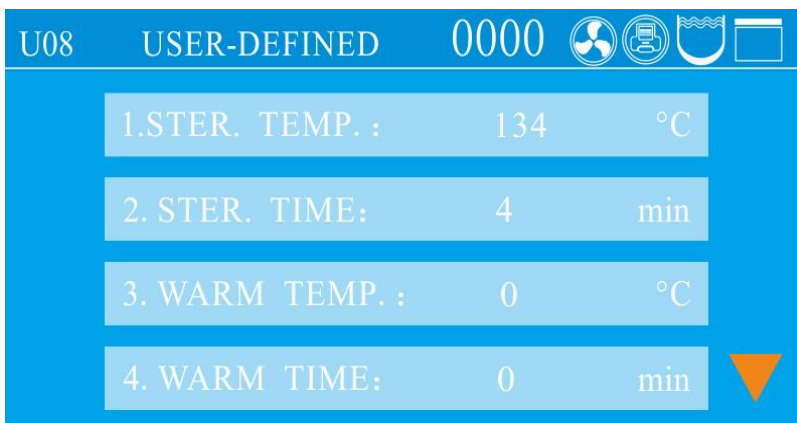

Press SET/ENT button to start modification, when the words are blinking, press UP or DOWN button to change the value, press SET/ENT again to confirm the modification, then press DATA to save and exit.

(3) Program introduction

- For GR-DA/DF there are ten basic modes. For GR-DR, there are eleven basic working modes available. And these working modes have been saved as nine basic programs (U01, U02, U03, U04, U05, U06, U07, U08, U09), one self-defined program (U10), and one drying program (U11) before delivery. U11 is only for GR-DR.
- The parameters of these ten or eleven basic modes cannot be deleted, but users can select any one as needed to modify parameters and it will become a new program after modified, and a maximum 60 programs (including the basic programs) can be created and saved;
- We set the default drying temperature and time to be lower and shorter to protect the articles. But when you run the cycles with drying, it is recommended to increase the drying temperature and time depends on different articles compared to the default

temperature/time of the fixed program, higher temperature and longer time will help for through drying.

- The DRY and ADD WATER icons are only for the automatic water feeding and drying models (For GR-SF or GR-DR)
- Basic working modes and parameters of corresponding basic programs (Any settings related with drying data are only for drying models: GR-DR, it doesn't mean that the whole mode is only for drying models, it just means the particular drying data in that mode is only for drying models) :

U01-Liquid program

- Sterilization process: Heating→Sterilizing→Steam exhausting→End
- Application: Sterilization of liquids

Name	Default Parameter	New Program Parameter Range
Sterilization temperature	121 °C	105 °C ~ 138 °C
Sterilization time	20 min	1 min ~ 6,000 min
Steam exhaust level	0	0-5
Cooling fan	On	On/Off
Extended time for purging cold air	0 min	0 min ~ 10 min
Cover opening temperature	80 °C	40 °C ~ 80 °C

U02-Liquid with warming program

- Sterilization process: Heating→Sterilizing→Steam exhausting→Warming→End
- Application: Sterilization of liquids, automatic warming is enabled after sterilization to keep some material in a soft state (e.g. for agar medium sterilization)

Name	Default Parameter	New Program Parameter Range
Sterilization temperature	121 °C	105 °C ~ 138 °C
Sterilization time	20 min	1 min ~ 6,000 min
Warming temperature	50°C	45 °C ~ 79 °C
Warming time	600 min	1 min ~ 9999 min
Steam exhaust level	0	0-5
Cooling fan	On	On/Off
Extended time for purging cold air	0 min	0 min ~ 10 min
Cover opening temperature	80 °C	40 °C ~ 80 °C

U03-Solid program

- Sterilization process: Heating→Sterilizing→Steam exhausting (water drainage)
→Drying→End
- Application: Sterilization of solids, glassware

Name	Default Parameter	New Program Parameter Range
Sterilization temperature	121 °C	105 °C ~ 138 °C
Sterilization time	20 min	1 min ~ 6,000 min
Drying temperature	124°C	80 °C ~ 160 °C
Drying time	40 min	0 min ~ 300 min
Steam exhaust level	3	0-5
Cooling fan	On	On/Off
Extended time for purging cold air	0 min	0 min ~ 10 min
Cover opening temperature	97°C	40 °C ~ 99 °C

U04-Wrapped load program

- Sterilization process: Heating→Sterilizing →Steam exhausting (water drainage)
→Drying→End
- Application: Sterilization of instrument packs, paper bags, and paper-plastic packaged instruments

Name	Default Parameter	New Program Parameter Range
Sterilization temperature	121 °C	105 °C ~ 138 °C
Sterilization time	30 min	1 min ~ 6,000 min
Drying temperature	124°C	80 °C ~ 160 °C
Drying time	40 min	0 min ~ 300 min
Steam exhaust level	3	0-5
Cooling fan	On	On/Off
Extended time for purging cold air	0 min	0 min ~ 10 min
Cover opening temperature	97°C	40 °C ~ 99 °C

U05-Fabric program

- Sterilization process: Heating→Sterilizing→Steam exhausting (water drainage)→
Drying→End
- Application: Sterilization of cloth and dressing packs

Name	Default Parameter	New Program Parameter Range
Sterilization temperature	121 °C	105 °C ~ 138 °C
Sterilization time	30 min	1 min ~ 6,000 min
Drying temperature	124°C	80 °C ~ 160 °C
Drying time	80 min	0 min ~ 300 min
Steam exhaust level	3	0-5
Cooling fan	On	On/Off
Extended time for purging cold air	0 min	0 min ~ 10 min
Cover opening temperature	97°C	40 °C ~ 99 °C

U06-Rubber program

- Sterilization process: Heating→Sterilizing→Steam exhausting (water drainage)
→Drying→End
- Application: Sterilization of heat and moisture-resistant tubular rubber, porous rubber, and similar items

Name	Default Parameter	New Program Parameter Range
Sterilization temperature	121 °C	105 °C ~ 138 °C
Sterilization time	30 min	1 min ~ 6,000 min
Drying temperature	124°C	80 °C ~ 160 °C
Drying time	40 min	0 min ~ 300 min
Steam exhaust level	3	0-5
Cooling fan	On	On/Off
Extended time for purging cold air	0 min	0 min ~ 10 min
Cover opening temperature	97°C	40 °C ~ 99 °C

U07-Fast program

- Sterilization process: Heating→Sterilization→Steam exhausting (water drainage)
→Drying→End
- Application: Only suitable for sterilization of exposed items. For immediate use.

Name	Default Parameter	New Program Parameter Range
Sterilization temperature	134°C	105 °C ~ 135 °C
Sterilization time	12 min	1 min ~ 6,000 min

Drying temperature	140°C	80 °C ~ 160 °C
Drying time	20 min	0 min ~ 300 min
Steam exhaust level	3	0-5
Cooling fan	On	On/Off
Extended time for purging cold air	0 min	0 min ~ 10 min
Cover opening temperature	97°C	40 °C ~ 99 °C

U08-Waste program

- Sterilization process: Standby→Water supply→Heating→Sterilization→Steam exhausting (water drainage)→Complete
- Application: Sterilization of waste, which can be solids, liquids, or a mixture of solids and liquids

Name	Default Parameter	New Program Parameter Range
Sterilization temperature	126°C	105 °C ~ 138 °C
Sterilization time	40 min	1 min ~ 6,000 min
Steam exhaust level	0	0-5
Cooling fan	Open	Open/Close
Extended time for purging cold air	0 min	0 min ~ 10 min
Start time for purging cold air	0 min	0 min ~ 250 min
Cover opening temperature	97°C	40 °C ~ 99 °C

U09-Agar program

- Sterilization process: Heating→Melting→Steam exhausting→Warming→End
- Application: Agar melting

Name	Default Parameter	New Program Parameter Range
Melting temperature	100°C	60 °C ~ 115 °C
Melting time	10 min	1 min ~ 6,000 min
Warming temperature	50°C	45 °C ~ 79 °C
Warming time	600 min	1 min ~ 9999 min
Cover opening temperature	80 °C	40 °C ~ 80 °C

U10- Self-defined program

- Sterilization process: Heating→Sterilization→Steam exhausting→Warming (Drying)→End

- Application: User can customize their own programs here

Name	Default Parameter	New Program Parameter Range	Remark
Sterilization temperature	121 °C	105 °C ~ 138 °C	
Sterilization success	By time	By time/By F0 value	
F0 value	10	1-300	
Sterilization time	20 min	1 min ~ 6,000 min	
Warming temperature	50°C	45 °C ~ 79 °C	
Warming time	600 min	0,1 min ~ 9999 min	0 indicates the warming function is not activated
Steam exhaust level	Level 3	Level 0 to Level 5	
Cooling fan	Open	Open/Close	
Drying temperature	140°C	80 °C ~ 160 °C	
Drying time	20 min	0, 0 min ~ 300 min	0 indicates the drying function is not activated
Extended time for purging cold air	0 min	0 min ~ 15 min	
Cover opening temperature	97°C	40 °C ~ 99 °C	
Start time for purging cold air	0 min	0, 1 min ~ 250 min	0 indicates the function is not activated

Note: 1. If the warming function is available, during the warming stage, the lid can be opened at any time to take out the sterilized materials. To continue warming, please close the chamber lid.

2. By time/By F0 value means the success of the sterilizing work can either depends on the time you set or the F0 value the system calculates.

U11- Drying program (Only for GR-DR)

- Drying process: Drying→Steam exhausting→Complete

Name	Default Parameter	New Program Parameter Range
Drying temperature	140°C	80 °C ~ 160 °C
Drying time	20 min	1 min ~ 300 min
Cover opening temperature	80 °C	40 °C ~ 80 °C

Note:

- The drying temperature refers to the temperature of the drying heat source rather than the displayed chamber temperature.
- The drying temperature should be adjusted to the recommended suitable temperature to ensure effective sterilization and protect the load being sterilized. If necessary, the

temperature can be increased appropriately within the drying data range. The correct drying temperature helps expedite the drying process.

● 7、 Start to sterilize

1) After power turned on, screen displays the latest saved program. If you continue to use the program, long press "START" to start the work directly.

2) Call the saved program: in standby mode, press the "up" or "down" key once, and the displayed program number will be increased or subtracted by 1 based on the current program number. If the current program number is U10, Press the "up" key once, the display program number is U11; if the "down" key is pressed once, the program number is displayed as u09; when the "up" or "down" button is continuously pressed, the displayed program number increases or decreases in 10 units. When the button is stopped, the specific parameters of the current program will be displayed on the two screens in turn. Select the appropriate program and press "start" to start the operation.

3) Modify or set up a new program and start:

For the specific modification method, please refer to Chapter 3 operation instructions creating, modifying and deleting procedures.

4) Clock check and calibration:

For details, please refer to the third part of the third chapter of the operating instructions, and for setting the timing start, see the fourth part of the third chapter

5) Program printing function: if the printer is installed and set in the administrator menu, enable it. Set up the print function before running the program. For details, please refer to P001 set by user administrator in Chapter 4, maintenance and management of instruments (3).

6) Exhaust setting:

During the process of sterilization, if the default exhaust level is not suitable, you can press the "func" and "up" keys at the same time for manual adjustment. Each time you press the "function" button, the exhaust level will increase by one level. If you press it again at the fifth level, it will be adjusted to level 0 and cycle up and down.

8、 Cycle finished&Open the cover

●When reach the set sterilizing temp.,melting temp. or drying temp, the system will

give a indicating sound.

- When all the program finished and temperature is lower than the cooling lock open temp., the COMP. will blink,system will send out 5 long sound,indicating the finish of the sterilization. You can open, pay attention not to get burnt.
- When the temperature is lower than 40 °C, the "COMP." will no longer flash, and the "ST-BY" will flash. The system will return to the standby state, and the cover can be opened safely.

Note:Do not press STOP randomly during the process. Do not open chamber or water tank drainage valve during process.

9、 Take out the sterilized articles

- 1) Always wear the heat insulation gloves when taking articles out after sterilization,and wait until the steam disappers before reaching into the sterilizer chamber.
- 2) When sterilize the liquids,make sure taking articles out with enough low temperature,due to slow cooling speed of liquid.
- 3) Press the "FUNC" + "DOWN" key at the same time to check the actual temperature of the load thermometer when the load thermometer is installed. When taking out the basket, pay attention that the thermometer is not stuck before taking it out.

10、 Turn off the power

- 1) The power switch should be turned off at the end of the day's sterilization work or when it is not in use for a long time.
- 2) At the end of the day's work, it is recommended to drain out all water in the sterilization chamber.

2.Creating,Modifying,Deleting the Program

1、 Creating and modifying the program

Find the required sterilization mode by pressing the "UP" or "DOWN" key, and then press the "SET/ ENT" key to enter the parameter modification interface. If there is a function of setting and enabling password in the background, the administrator password should be input. In the setting process, if you press the "DATA" key, the parameter settings will not be saved and return to the standby state; if you press the "SET/ ENT" key during the setting process, the parameter settings will be saved and a new sterilization mode will be created. Press "START" again to run the program.



2、 Deleting Program

- If you need to delete the program, press DELETE PROGRAM
- Default programs can not be deleted.

3、 Setting the sterilizing time

- Some items (such as liquid) have high thermal inertia, in order to obtain the ideal sterilization effect, it is recommended to use the load thermometer;if no,set a longer sterilization time.

For example, for 3L water in a flask,when the chamber temperature reaches set temperature after 20 minutes, but the liquid in the bottle hasn't reach yet, it needs 33 minutes more to reach. So, the sterilization time should set to be 53minute. Actual required sterilizing time(53min)=Normal sterilizing time(20min)+Delay time(33min)





- When installed with load thermometer, the system will begin sterilization process only when the sensor put in the liquids reaches the set temperature.
- When sterilize waste processing bags, 300-500ml water will help to shorten the heating up time.
- A delay time is also needed for plastic products.

4.Setting of Administrator Menu

U02 LIQUID & WARM 0000    





1. PRINTER:	DISABLE
2. PRINT FREQUENCY:	1 min
3. CHAMBER TEMP. COMPENSATION:	-0.3 °C
4. LOAD THERMOMETER:	ENABLE
5. LOAD TEMP. COMPENSATION:	0 °C

PRESS "DATA" TO EXIT

U02 LIQUID & WARM 0000    





6. MAX WORKING TEMP. :	145 °C
7. PRESSURE SENSOR:	DISABLE
8. PRESSURE UNIT:	KPa
9. PRESSURE COMPENSATION:	0 kPa
10. DATE DISPLAY FORMAT:	MM/DD/YY

PRESS "DATA" TO EXIT

U02 LIQUID & WARM 0000    





11. COOLING FAN:	DISABLE
12. SAFETY VALVE TEST:	DISABLE
13. SAFETY VALVE TEST PERIOD:	DISABLE
14. SINCE THE LAST TEST:	0 DAYS
15. BUTTON SOUND:	ENABLE

PRESS "DATA" TO EXIT

U02 LIQUID & WARM 0000    

16. LOCAL ALTITUDE:	300 m
17. BOILING POINT TEMP. :	99.1 °C
18. LANGUAGE SELECTION:	EN.
19. SOFTWARE VERSION:	1.00 +d.4
20. SCREEN BRIGHTNESS:	5

PRESS "DATA" TO EXIT

U02 LIQUID & WARM 0000    

21. TYPE OF PRESSURE DISPLAY: ABSOLUTE 





22. FILTER TEMP. COMPENSATION: 0 °C

23. RESET FILTER USED TIMES: DISABLE

24. PRINTING LOAD TEMPERATURE: DISABLE

25. PRINTING FILTER TEMPERATURE: DISABLE 

PRESS "DATA" TO EXIT

U02 LIQUID & WARM 0000    





26. Five level authority switch: DISABLE 

27. Number of operator: 6 6 7 7 8 8

28. Status of the operator:

29. Cooling water tank temperature: 45 °C

30. Wifi link: DISABLE 

U02 LIQUID & WARM 0000    





26. Five level authority switch: DISABLE 

27. Password of administraton: 6 6 7 7 8 8

28. Status of the operator:

29. Cooling water tank temperature: 45 °C

30. Wifi link: DISABLE 

U02 LIQUID & WARM 0000    

36. Times of smart cleaning: 0 

37. Timed low temp. wash: DISABLE

38. Time to start low temp. wash: 00 : 00

39. Drainage/cleaning frequency: 7

40. Last drainage/cleaning time: 00 00 , 2000 

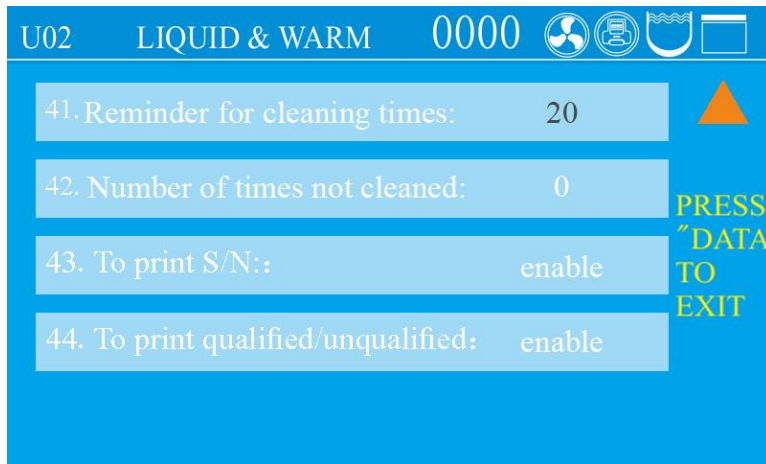

- Under standby condition, press SET/ENT to enter into administer menu, press UP or DWON to choose PARAMETER SETTING, press SET/ENT to enter into, then input password.

- After enter into the menu, press UP or DOWN to choose the item you want to modify, press SET/ENT to enter into and after modification, press SET/ENT again to save and exit.

- The default password is 667788, you can modify if you want, if you forget your modification, please contact distributor.

- When doing administrator setting, press STOP will go back to standby screen, press DATA to go back to the previous screen.

● Administrator Menu:

- 1、 PRINTER: You can choose to print only data or “data&curve”
- 2、 PRINTE FREQUENCY: Can choose 1-10 minutes
- 3、 CHAMBER TEMP.COMPENSATION: Range from -5°C to 5°C.
- 4、 LOAD THERMOMETER: Enable and disable, if you choose Enable, screen will show Object temperature value.
- 5、 LOAD TEMP. CMPENSATION: Range from -5°C to 5°C。
- 6、 MAX WORKING TEMP.: Range from 138°C to 145°C, used for safety valve test
- 7、 PRESSURE SENSOR: If pressure sensor is installed and enabled, the screen will display the value, if no, screen will show “---”
- 8、 PRESSURE UNIT: You can choose from kpa、 psi、 bar。
- 9、 PRESSURE COMPENSATION: Range from -5kPa to 5kPa。
- 10、 DATE DISPLAY FORMAT: Year/Month/Date or Date/Month/Year
- 11、 COOLING FAN: Enable and disable

- 12、SAFETY VALVE TEST: Choose Enable can start the safety valve test
- 13、SAFETY VALVE TEST PERIOD: You can choose how often to remind you to do test,30、 60、 90、 120、 150、 180、 210、 240、 270、 300、 330、 360 day or off.
- 14、SINCE THE LAST TEST: How many days since the last safety valve test
- 15、BUTTON SOUND: Enable and disable
- 16、LOCAL ALTITUDE: Range 0~3000
- 17、BOILING POINT TEMP.: Local boiling point
- 18、LANGUAGE SELECTION: Chinese and English
- 19、SOFTWARE VERSION: Can not be modified
- 20、SCREEN BRIGHTNESS: Default is 23,adjust range is 10-25
- 21、TYPE OF PRESSURE DISPLAY: Gauge and absolute
- 22、FILTER TEMP COMPENSATION: Range -5°Cto 5°C
- 23、RESET FILTER USED TIMES: one cycle will increased once, if machine with filter
- 24、PRINTING LOAD TEMPERATURE:to print the PT 100 sensor temperature or not
- 25、PRINTING FILTERTEMPERATURE:to print filter temp. ,if machine with filter
- 26、FIVE LEVEL AUTHORITY SWITCH: default is on
- 27、PASSWORD OF ADMINISTRATOR:667788, if you turn on 26: five level authority switch, this one will become Operator 1-8 if you want to create.
- 28、SATAUS OF THE OPERATOR: default is off
- 29、COOLING WATER TANK TEMPERATURE:default 45°C , range from 45-65°C
- 30、WIFI LINK:Turn on can link machine to Wifi
- 31、MODBUS COMMUNICATION BAUDRATE:Set Modbus baudrate
- 32、MODBUS COMMUNICATION IP ADDRESS:Range 1-127
- 33、HIDDEN STERILIZATION MODE: choose the programs you want to hide
- 34、EMPTY WATER AFTER STERILIZATION:for solid mode, for one-click drainage function.
- 35、ONE-CLICK DRAINAGE TEMPERATURE:default 45°C , range from 45-80°C
- 36、TIMES OF SMART CLEANING: how many times you want to repeat smart cleaning,default 0,range 0-10. Only valid when you have automatic water feeding function.
- 37、TIMED LOW TEMP. WASH: Default is off
- 38、TIME TO START LOW TEMP. WASH:make appointment for auto start low temp. wash, need to add water and drain the water manually when it finished for SA and need

to drain manually for SF/SR if not equipped with one click drainage.

39、 DRAINAGE/CLEANING FREQUENCY: default is appear each 7 days, range is 1-30 or off. If you want to turn off the smart cleaning, need to turn off 39 and 41 together.

40、 LAST DRAINAGE/CLEANING TIME:can not be modified

41、 REMINDER FOR CLEANING TIMES:default is appear after 20 cycles, range is 1-60 or off.If you want to turn off the smart cleaning, need to turn off 39 and 41 together.

42、 NUMBER OF TIMES NOT CLEANED:can not be modified

43、 TO PRINT S/N:

44、 TO PRINT QUALIFIED/UNQUALIFIED:

3.Clock Checking and Calibration

Press SET/ENT to enter into management menu, press UP/DOWN to choose “CHECK AND MODIFY TIME”, press SET/ENT to enter into next menu. After modifying,press SET/ENT to save and exit, press DATA to exit without saving.

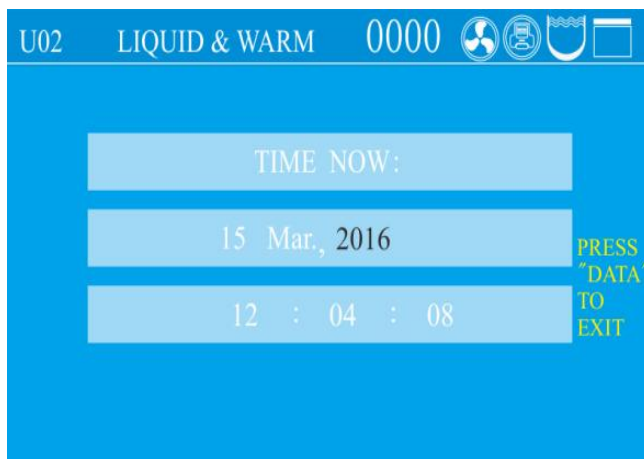
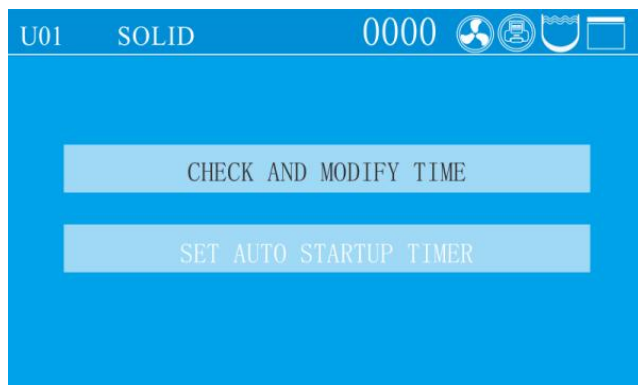

Adjustable Time Range:

Name	Adjustable Range
Year	2000~2099
Month	1~12
Date	1~31
Hour	0~23
Minute	0~59
Second	0~59

●Please make sure you set reasonable date, if not, the system will switch back to the correct date. For example, If you set Feb.30,2018, system will switch to Mar.1,2018 after 23:59:59, Feb.30,2018.

4.Set auto start timer

Press SET/ENT to enter into management menu, press UP/DOWN to choose “SET AUTO STARTUP TIMER”, press SET/ENT to enter into next menu. After modifying,press SET/ENT to save and exit, press DATA to exit without saving.

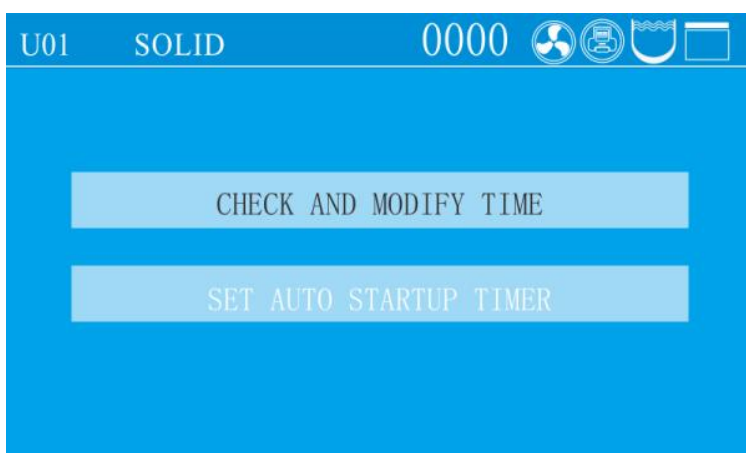

★Note: ○Please recheck the time setting, if the time is not set correctly, the auto start timer will follow the wrong setting.

5.Account management

First, after the instrument is powered on and turned on, press the "SET/ENT" key,the display is as follows:

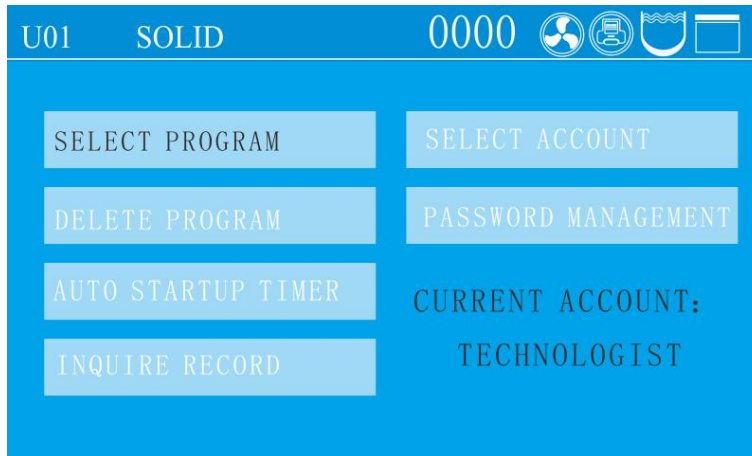

Press UP and DOWN to choose Select Account, then press SET/ENT to enter.

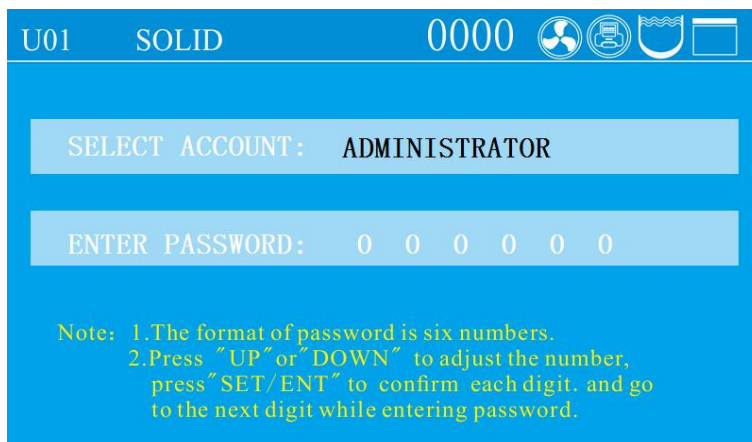

Select the account you want to use, and then enter the correct password to enter the standby interface.

Note: The instrument will remember the last account used. For example, Operator 2 was used last time, and the account first displays Operator 2 after startup

1.Operator

After selecting the operator account and entering the password (the initial password is 000000), press the "SET/ENT" key, and the display is as follows:



The operator has a total of 3 permissions, as shown in the figure. When the display font is black, it means it is selected, and then press the SET/ENT key to enter the corresponding menu.

1.1.Record Query

Enter the record query interface as follows:



A:The latest record will be displayed automatically

B:Five records are displayed on each page. When there is content on the next page, the lower triangle in the lower right corner indicates that there is an earlier record page below, and the upper triangle in the upper right corner indicates that updated records can be switched

C:Each record is displayed by the time when the sterilization was started and whether the sterilization was successful.

D:You can press the UP or DOWN key to switch up and down to select the record.

When the next record is reached, pressing the DOWN key again will switch to the next earlier record interface.

E:After selecting a record and pressing SET/ENT, the screen will display this sterilization information, as follows:

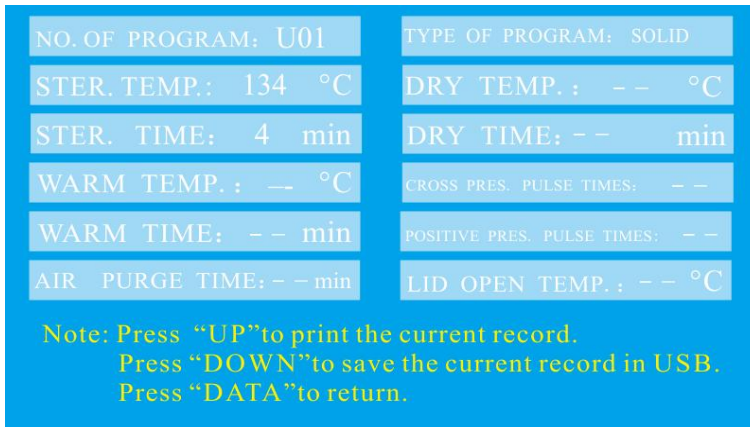

1.2.Account switching

Enter account switching, and the interface displays the following content. The font of the account name flashes, indicating that the status can be switched, press "UP" or "DOWN" to select the user to be switched, and press "SET/ENT" to confirm. The system will automatically switch to the password option. At this time, press the "SET/ENT" key to confirm. The initial password is "000000". After that, the system will prompt "Account switching succeeded!".

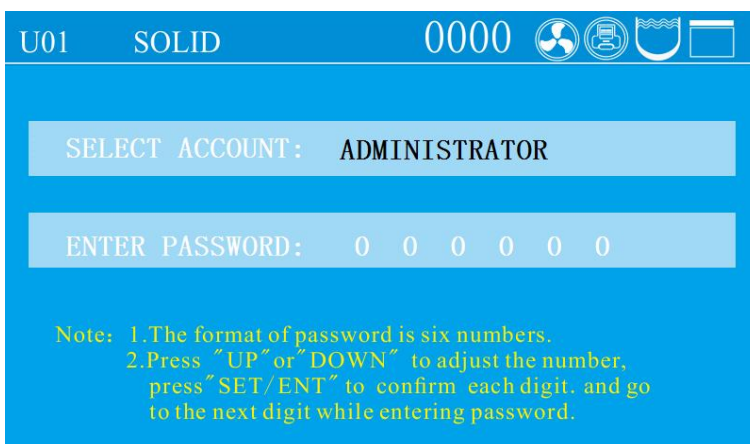

1.3 Password management

After entering the password management, the password confirmation interface will pop up first, as shown below:

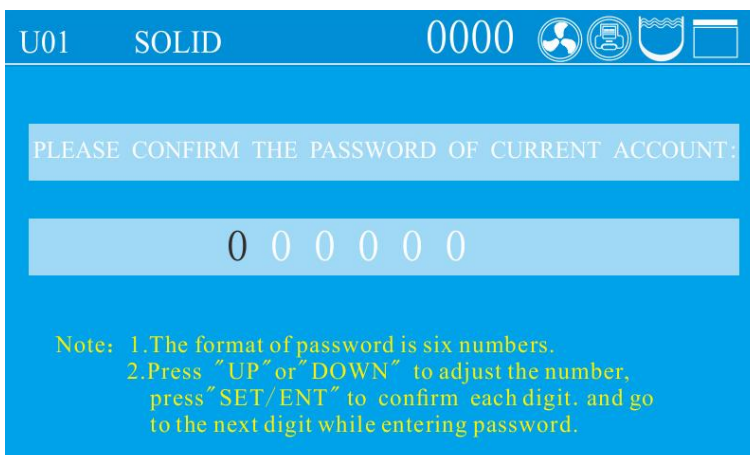

Press the "SET/ENT" key to confirm the password for the first time. The initial password is "000000".After confirmation, the following interface will appear. At this time, press the "UP" or "DOWN" key to change it into a password that you can easily remember,The reset account and password account can be confirmed according to the status displayed on the interface. No change is required.

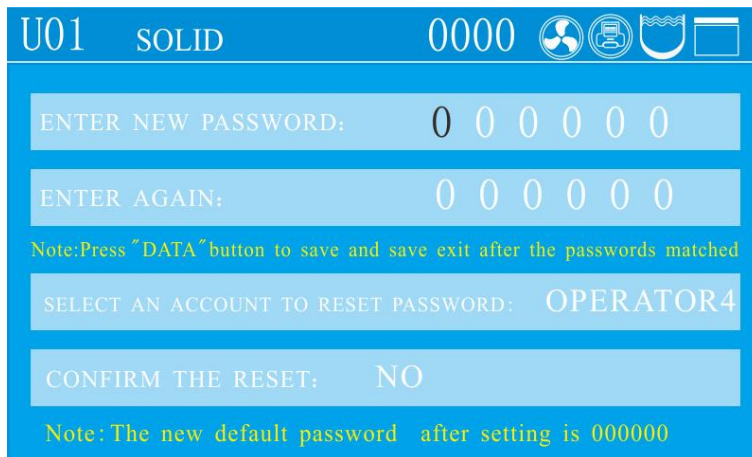

2、Technologist

After selecting the technologist account and entering the password (the initial password is 000000), press the "SET/ENT" key,the display is as follows:



The record query and account switching are the same as those of the operator.

2.1.Program settings, see “Setting of administrator menu”.

2.2.Appointment for auto start: see “Setting auto start timer”

2.3.Password management

The interface is as follows:

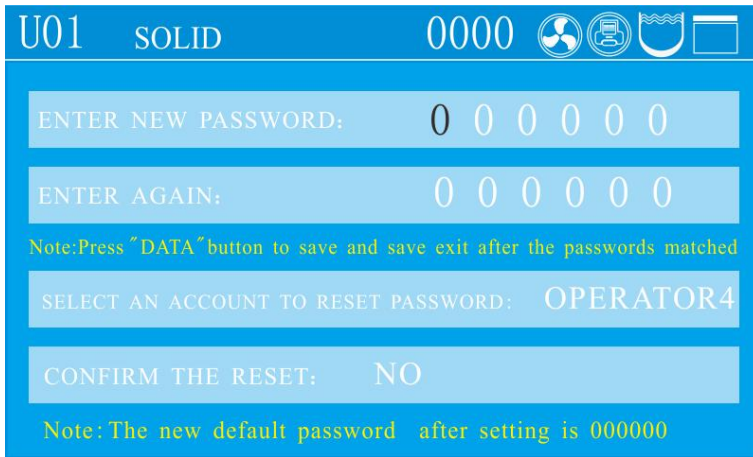

The password modification method at the top of the screen is the same as that of the operator. The technologist has a function to reset other account passwords in this interface. The technologist can only reset the password of the operator.

3、Administrator

After selecting the administrator account and entering the password, the initial password is 000000. Press the "SET/ENT" key, and the display is as follows:



The parameter setting and password management permissions are the same as those of the technologist. For parameter settings, please refer to the description in "Setting of administrator menu".

Chapter 4 Maintenance

★ Note: Cut off the power supply and confirm that the sterilization chamber has been cooled before maintenance or repair, make sure pressure is 0 on the pressure gauge.

I. Cleaning

1. Drainage of the water tank

- Use a silicone hose to connect the water tank drain port to a collection container or the sewer, and then open the drain ball valve to drain the water from the water tank.

★ Note: When the instrument needs to be transported or left unused for a long time, the water in the water tank should be drained.

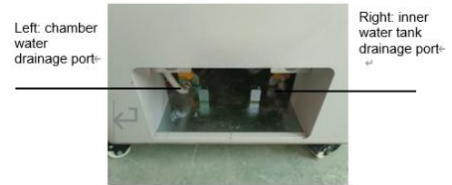

2. Water change and cleaning of the sterilization chamber

1) Water change of the sterilization chamber

- If the water in the sterilization chamber is used repeatedly for a long time, impurities in the water can easily clog the solenoid valve, which may lead to rust and noise in the solenoid valve.
- If the load to be sterilized contains slightly corrosive substances, the water should be changed after each sterilization cycle. To drain the water, connect one end of the drain hose to the sterilization chamber drain port, and the other end in a collection container. Open the drain valve to drain the water, and then close the valve by turning it counterclockwise.

⚠ Note: Before opening the sterilization chamber drain valve and the water tank drain valve, ensure that the instrument is not running and the master controller temperature is below 40 °C.

2) Cleaning of the sterilization chamber

- Although the water tank and pipeline are equipped with mesh filters, debris from the sterilized load may still cause faults, clog the pipeline, or accumulate on the heating tube, thereby reducing the service life of the heating tube. Therefore, please clean the sterilization chamber regularly to remove scale and debris.
- Use a brush with a handle to clean the bottom of the sterilization chamber, but be careful to operate gently, otherwise, it may damage the electric heating tube and the

temperature control switch.

- Wipe the sterilization chamber clean with a damp soft cloth, and then rinse it with hot water (do not use any cleaning agent).
- Preferably clean the chamber once a week.

3. Cleaning of water outlet filters (if there is)

- The water inlet and outlet filters are located at the lower rear of the instrument. To clean them, first use a hex wrench to unscrew the end cap, remove the filter elements, rinse the filter elements thoroughly with clean water, put the cleaned filter elements back in place, and then re-screw the end cap tightly.

- Remove and thoroughly clean the meshes inside the filter elements, and then re-roll and re-install them properly in the filter elements.



- Clean the filters at least once a week.

 **Note:** When there is still water remaining in the water tank, do not open the water inlet filter. When the chamber temperature is above 40 °C, do not open the water outlet filter.

4. Cleaning and maintenance of the heating element/chamber drain filter/water level sensor

- Take out the water level plate, and check if the surface of the electric heating element

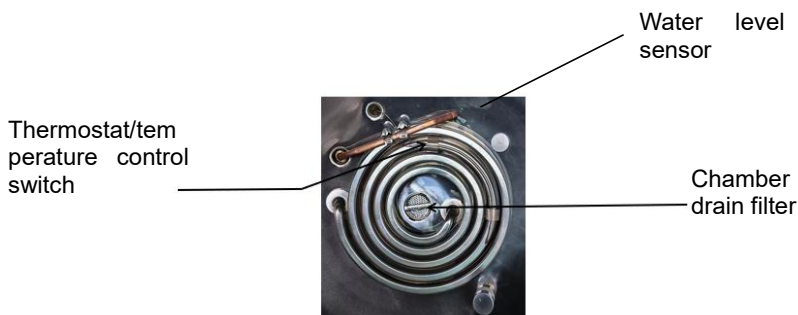

is clean. If there is any dirt, gently wipe it with a soft brush, rinse it with water, and then drain the dirty water.

- When wiping the dirt, be careful not to move or damage the temperature control switch.
- Remove and clean any debris from the chamber drain filter. (Rotate the filter out of the fixed position to take it out, and rotate it into the fixed position for re-installation)
- Preferably conduct the cleaning work once a month.

5. Cleaning of the instrument surface

- Gently wipe the instrument surface with a soft cloth. For hard-to-remove stains, remove them with a small amount of neutral detergent, and then take care to wipe the surface dry with a cloth.
- Do not use phenol or oil thinner to clean the instrument surface, otherwise it may damage the instrument surface or lead to paint peeling.

6. Maintenance of the sealing ring

- Check if the sealing ring is damaged. If there is any damage, replace it immediately.
- Clean the surface of the sealing ring regularly to remove any dirt. Use a small amount of detergent and wipe the surface with a damp cloth during cleaning.
- Gently wipe the instrument surface with a soft cloth. For hard-to-remove stains, remove them with a small amount of neutral detergent, and then take care to wipe the surface dry with a cloth.

2.Parts Maintenance

1、 Check of Leakage Circuit Breaker

- Press the T button at the back of leakage circuit breaker,if it dumps off,means normal,if no, please turn off and contact the dealer
- Press the power switch,pull up the leakage circuit breaker,can connect the power again
- Check once half year

2、 Safety valve test

- Enter into the administer menu(Refer to Setting of Administor Menu), then press DOWN to choose the safety valve test,choose ENABLE,press SET/ENT to save and exit.
- The instrument will start to do safety valve test, you can press STOP to stop it.
- If the temperature goes over the max temperature and safety valve is not releasing, means there is problem with the safety valve, please stop the test and contact distributor.
- Press STOP can put an end to the testing,screen will show E03,this is normal, you can press STOP button after the temperature goes down to 105℃ to return to standby condition.

3、 Replacement of sealing ring

- Open the cover.
- Insert the lower part of the fixing ring with a slotted screwdriver, gently pry upwards, take out the old sealing ring, and then take out the fixing ring of the sealing ring from the old sealing ring.
- Clean the dirt on the fixing ring of the sealing ring and the contact part between the chamber and the sealing ring with a cloth.
- There are two rings, one is sealing ring, one is stainless steel fixing ring. Place the fixing ring on the bottom of the groove on the new seal ring, and slowly press the seal ring into the outer edge of the sterilization chamber until it is completely inserted. If the retaining ring slips out, it can be pressed back into the fixing groove with a soft ham. When the sealing ring is fully in place, the inner part of the upper edge is slightly lower than the outer edge of the sterilization chamber, and the lower edge touches the metal surface of the base. Press the surface of the sealing ring lightly by hand to make it flat. If the sealing ring surface is not flat, the cover will be difficult to close.
- Run the cycle and observe the leaking situation of the sealing ring.

4、 Uninstall the left and right side panels

- The left and right side plates of the instrument are designed to be taken off for convenient maintenance.
- The bolts for locking the side plate are located at the bottom of the instrument and can be unscrewed by hand or tool.

Chapter 5 Troubleshooting

- The automatic control system of the sterilizer monitors the real time operation of the instrument. Whenever any failure occurs,the system may send out alarm and display the error code, then please press STOP button to return standby status, and turn off the power, check the error code and handle on time.
- To make sure safety, only open the lid when there is no pressure inside and temperature is lower than boiling point. For liquid model,do not press STOP before temperature is lower than the boiling point,so as to avoid liquid overflowing.

Error Code	Possible Cause	Suggestion
E-01	Chamber cover interlock failure	Check if the cover opening/closing handle is set in place. If the handle is in place but the error still exists, contact the local DEALER OR MANUFACTURER Service.
E-02	Altitude not set	Reset the altitude
	Temperature sensor obstructed by the load	Carefully read the instructions for loading
	Heating system failure	Check the heating tube and wiring, or contact the local DEALER OR MANUFACTURER Service
E-03	Water level sensor contaminated	Clean the water level sensor
	Mismatch between the pressure gauge reading and the temperature	1. Check for blockage in the solenoid valve and pipeline 2. Check the temperature sensor and its wiring 3. Check the pressure switch and its wiring
	Temperature control switch error	Replace the temperature control switch
E-04	Abnormal temperature fluctuation due to abnormal power supply fluctuation	Check whether the power supply voltage is between 198 V - 242 V
	Cold air not fully exhausted	Check the pipeline for blockage, and ensure the load is placed correctly
E-06	Chamber temperature sensor plug disconnected from or in poor contact with the circuit board	Re-connect the temperature sensor plug
	Chamber temperature sensor failure	Replace the temperature sensor
E-07	Master controller temperature sensor plug or wiring short-circuited	Replace the temperature sensor
E-10	Exceptions such as power failure during sterilization	Re-sterilization
E-11	Low external water supply pressure	Adjust the water supply pressure
E-12	Mismatch between temperature sensor and pressure gauge readings	Calibrate or replace the temperature sensor
	Micro pressure switch failure	Replace the micro pressure switch or contact the local DEALER OR MANUFACTURER Service

Error Code	Possible Cause	Suggestion
E-14	Drying heating system or thermostat failure	Contact the local DEALER OR MANUFACTURER Service
E-15	Low water level in the sterilization chamber	Add water to the sterilization chamber
	Water conductivity less than 10 us/cm	Add an appropriate amount of salt to increase the conductivity to 10-15 us/cm.
	Steam exhaust solenoid valve contaminated	Clean the steam exhaust solenoid valve
E-16	Load temperature sensor plug disconnected from or in poor contact with the circuit board	Re-connect the temperature sensor plug
	Load temperature sensor failure	Replace the temperature sensor
E-18	Solenoid valve and pipeline blocked	Clean the solenoid valve and pipeline
	Error in the temperature sensor/pressure sensor or its wiring	Disconnect and re-connect the temperature sensor/pressure sensor plug. If the issue persists, contact the local DEALER OR MANUFACTURER Service.
E-19	Container water level sensor contaminated	Wipe the water level sensor inside the container with a clean cloth
E-20	Safety valve test circuit failure	Contact the local DEALER OR MANUFACTURER Service
E-24	Safety valve pipeline blocked	Clean the safety valve pipeline
	Safety valve failure	Replace the safety valve
E-25	Drying temperature sensor plug disconnected from or in poor contact with the circuit board	Re-connect the temperature sensor plug
	Drying temperature sensor failure	Replace the temperature sensor
E-26	Pressure sensor plug disconnected from or in poor contact with the circuit board	Re-connect the pressure sensor plug
	Chamber pressure sensor failure	Replace the pressure sensor
E-27	Chamber pressure sensor plug or wiring short-circuited	Contact the local DEALER OR MANUFACTURER Service or replace the pressure sensor
E-31	Low external water supply pressure	Adjust the water supply pressure
	Water inlet filter clogged	Clean the water inlet filter
	Water tank level sensor error	Replace the water tank level sensor
E-32	Water tank level sensor contaminated	Wipe the water level sensor inside the water tank with a clean cloth
E-35	Filter element exhaust pipeline blocked	Clean the filter element exhaust pipeline
	Filter element sensor location with accumulated water	Adjust the instrument's level to make the end close to the sterilization chamber filter element slightly lower than the far end
	Filter element temperature sensor in poor contact, uncalibrated, or failed	Properly re-connect, recalibrate, or, when the error cannot be eliminated, replace the temperature sensor

Error Code	Possible Cause	Suggestion
E-36	Overheat protection sensor open-circuited or short-circuited	Re-connect the temperature sensor plug
E-37	Low water level in the sterilization chamber	Add water to the chamber
	Water level sensor contaminated	Clean the water level sensor
	Water level sensor failure	Contact the local DEALER OR MANUFACTURER Service
E-38	Chamber cover interlock failure in the standby state	Check if the cover opening/closing electromagnet pops up or is jammed, or contact the local DEALER OR MANUFACTURER Service
E-50	Boil-dry protection failure	Contact the local DEALER OR MANUFACTURER Service
Earth leakage circuit breaker tripped	Instrument leakage or short-circuited	Contact the DEALER OR MANUFACTURER Service

Below are note messages. You can press the STOP key very shortly to return to the standby state.

Note Message	Suggestion
Over temperature in the chamber !	Wait for the temperature to decrease before proceeding with work
Clean the chamber, drain the water then remove this note while no water in the chamber!	Please clean the water level sensor, heating tube, and sterilization chamber, and then drain the water from the chamber to clear this message
Unreasonable setting of auto start time!	Reset the time
The safety valve test hasn't been done for too long!	Test the safety valve
Water shortage in water tank	Manually add water or enable automatic water filling
Please wait for the micro pressure to release.	There is still pressure in the chamber. Please wait for it to be released



● The above table lists some simple errors, causes, and suggestions for repair. If you are unable to deal with these problems, please contact dealer or manufacturer and provide the following information:

- 1) Instrument model and S/N
- 2) Damaged part and fault phenomenon and sterilized load(error code, if any)
- 3) Operation details before the error appears
- 4) Date of purchase of the instrument
- 5) Software version

Drawell International Technology Limited

**Shanghai Drawell Scientific Instrument
Co.,Ltd.**

Chongqing Drawell Instrument Co.,Ltd.



Add: Suite 2204, Building No.11, Shiyou Road No.1, Yuzhong District,
Chongqing, China

Tel: 0086-023-63268643

Web : www.drawell.com.cn

Email : sales05@drawell.com.cn