



Operation Manuals

Floortype Refrigerated Centrifuge

Model: iDL-7MC

 Warning

 Precaution

 Direction



Intelligent type

Thanks for using Drawell centrifuge! In order to get quick and sincere service, please read the operation manuals carefully before you operate!

Contents

Safety Notices	1
1. General Introduction	5
1.1 Product Name and Classify	5
1.2 Application and Scope	5
1.3 Centrifugal Theory	5
2. Main Technical Parameters	5
3. Structure Characteristics	7
3.1 Structure	7
3.2 Main Frame Shap	7
3.3 Drive System	7
3.4 Refrigeration System	8
3.5 Electric Control Part	8
4. Installation and Adjustment	9
4.1 Unpacking of package	9
4.2 Installation Requirements	9
4.3 Adjusting Requirements	10
5. operation	12
5.1 Safety Notice	12
5.2 Preparation and Installation of the Rotor	14
5.3 Operation Procedures & Directions	15
6.Maintenance & Trouble Shooting	16
6.1 maintenance	17
6.2 Trouble Shooting	17
7. Transportation and Storage	19
7.1 Transportation	19
7.2 Storage	19
Warranty	20
Quality Certificate	21
Packing List	22
Warranty Card	23
Service Records	23
Service Manual	24

Safety Notices

We appreciate your business with DRAWELL. To prevent any potential accident, please operate centrifuges according to the following safety protocol.

Safety in installation and maintenance

- * The electricity should be cut off before repairing. Please take care if instrument must be repaired with electricity on. Before opening any lids, please cut off the electricity and wait for 4 minutes.
- * Make sure for placing centrifuge on a steady floor or table and adjusting the level for normal operation.
- * The power supply of centrifuge is the type of nameplate. If you have any problem of the type of power, please consult the dealer and power supply bureau in your place.
- * As safety measures, the centrifuge equipped with a single-phase three-phase cable, and the longer cable connects with casing as the protection grounding. If your sockets hasn't protection grounding, please contact your electrician to replace the original socket without allowing security role of single-phase with three-wire power cable to be invalid.
- * When replacing parts, the serviceman should use parts manufacturer required with the same function of original parts. The unrecognized alternative parts many cause fire, electric shock or other hazards.
- * The room should be installed an air-conditioner for good refrigerating effect when temperature is higher than 35.°C.
- * Please keep cleaning of the installation site for the centrifuge. Pay attention to the blockage of condenser, it should be cleaned once in three months for guarantee the refrigerating effect.
- * Don't unpack and repair instrument by oneself. Please contact with our technicians for necessary matter.

Attention for fireproofing

- * Small breaker (Air switch) can protect the circuit when centrifuge

over-currents. Please use breaker (air switch) with same specification and model when replacing it.

* The centrifuge is not designed for the flammable and explosive matters. You cannot make centrifugal for the matter (chloroform, acetaldehyde), and cannot put the matters in the centrifuge or store them around centrifuge within 30cm.

Attention for the safe operation

* Please use the rotor and accessories which are designed for this centrifuge.
* Please check rotor, bucket and other accessories carefully before operation.
* Input the right rotor number before operation for not exceeding of its max speed.

Attention: The max speed of rotor, buckets and accessories may be different.

- * Make sure that rotor can be installed on main spindle correctly for not damaging the spindle part.
- * Put all buckets (the same model) in rotor before operation for not exceeding its max imbalance volume, close the rotor lid then.
- * Make sure is the centrifugal chamber is cleaned before operation.
- * Don't reduce the speed by hand when it is rotating.
- * Don't open door lid when rotor is rotating
- * Don't move centrifuge lid when rotor is rotating.
- * Anything is not allowed to enter into centrifuge during operation.
- * If tube broken in centrifugal chamber, please clean out the fragments before next operation.
- * If there is water condensing in centrifugal chamber, please wipe up it with clean cloth.
- * The container with liquid should not be put around centrifuge; the electric parts may be damaged for water spraying in.
- * If centrifuge is irradiated by ultraviolet radiation for long time, the outer skin may be faded. Clothing should be covered for avoiding irradiation.
- * This centrifuge must not be used to separate the sample which producing flammable and explosive gas. The stock around centrifuge is also forbidden.
- * It is forbidden to operate the rotor exceed of its max speed. If user has not

set rotor type according with the number on rotor lid, all damages caused by above misoperation should be borne by user.

- * please wipe up the rotor with neutral cleaning mixture after taking out for avoiding corrosion and then stock it at dry, ventilated place. Central hole in rotor should be smeared some lubricating grease for protection.
- * All action on rotor should be soft, and rotor should be taken out vertically for protecting the shaft.
- * Please wipe up the water in centrifugal chamber if it is leaving unused. Some lubricating grease should be smeared on drive shaft for protection.
- * The interval of between two operations is no less than 5 minutes for avoiding damage of compressor.
- * If rotor damage occurring, allowable space to move for centrifuge is 30cm. * Anything should not be put around centrifuge within 30cm, especially for flammable and explosive matter.
- * It is not allowed to lean on the centrifuge when it is running. Non-staff are not allowed to stay in the operation area.
- * When unpacking rotor and replacing rotor accessory and sample under low-temperature, the operator must adapt protection actions for avoiding tissue frostbiting.
- * Centrifuge must be stopped when ant abnormal phenomena occurring or error code displaying, then you should inform our company or service agent soon.

Attention for safety in chemistry and biology

The routine manipulation may include all kinds of liquid and test sample which may be the disease-causing and poisonous matters. The centrifuge can not be manipulated with the matters unless you have taken the protection measures.

- * Please pay attention to the liquid explanation in container before operation.
- * Be careful of the infectious liquid. If not understanding the provided sample. Please at least make sure that they aren't microbe. You must make further aerosol protection (the suspended speck aren't in the air, such as smoke and fog). For the easier disease-causing hepatitis virus (B or C), HIV, atypical myco-bacteria and the fungus of physical structure.

- * The infectious samples must be manipulated according to the manipulating program and method in lab for avoiding expanding disease.
- * The spilt matters may produce aerosol (the suspended speck in the air, such as smoke and fog.), so please pay attention to the warning about aerosol (the suspended speck in the air, such as smoke and fog.)
- * Only use the suitable rotor and adapter. The centrifuge can not be manipulated with disease-causing, poisonous or radioactive matters unless you substance (according to the “Laboratory Biosafety Manual” of the World Health Organization.) is manipulated, the air safety level must be monitored. The superior substances require a higher level of safe protection measurements.
- * You should follow the environment security and protection requirements when destroying the discarded liquid.
- * Users have responsibility to clean and sterilize centrifuge and accessory if you need maintenance service from our company.

In a word, centrifuge is a high-risk common equipment in the lab which refers to safety of people. Correct operation can avoid and reduce accidents.

1. General Introduction

1.1 Product Name and Classify

Floor type Refrigerated Centrifuge DL-7MC

It belongs to Class I of medical laboratory equipment according to the management of “The Classified Catalog of Medical Devices”.

It belongs to Class I of ordinary equipment with protective grounding according to the protection against electric shock.

1.2 Application and Scope

The centrifuge makes use of centrifugal theory to separate, purify and condense various mixture liquid or emulsion with tiny particle and similar density. It can be widely used in hospitals, blood banks, pharmaceutical and biology, medicine, agricultural science laboratory and production units. Under the cooling condition, it makes separation, sedimentation and concentration for blood products, biological products, chemical products, pharmaceutical products. This machine is with large centrifugal force, large capacity. It is the routine equipment of separation and production. The machine used AC induction motor, frequency control, microprocessor control, touch keys and digital display panel is a new generation of models.

1.3 Centrifugal Theory

Centrifuge makes use of the strong RCF that centrifuge rotates with high speed in order to accelerate the setting speed of the granule in the liquid, and separate, condense and purify the matters with different settling coefficient and density.

2. Main Technical Parameters

- | | |
|------------------------------------|---------------------------|
| 1. Max. Speed: 8000r/min | 2. Max Capacity: 6×1000ml |
| 3. Max. RCF(field): 116200xg | 4. Time Range: 0~23h99min |
| 5. Noise: ≤65dB | 6. Temp Range: -20℃~+40℃ |
| 7. Speed control accuracy±50 r/min | 8. Ac/Dc Rte: 0-9 Grade |
| 9. Program storage capacity: 35 | |

Rotors for option (According to the customer's request to process various rotor)

Rotor data

Rotor:According to the customer's request to process various rotor			
Number	Max Speed	Max RCF	Capacity
NO.1 Angle Rotor	8000r/min	11620xg	4×1000ml
NO.2 Angle Rotor	7000r/min	11500xg	6×1000ml

Basic formula for centrifugal technology theory :

Relative Centrifugal Force $RCF = 1.12r \left(\frac{rpm}{1000} \right)^2$ r = Rotor radius
rpm = Speed

Sedimentation Coefficient $S = \frac{1}{\omega^2 r} \times \frac{\delta r}{\delta t}$ ω = Acceleration
 k = Rotor k-factor

Test Time $t = k/S$ S = Sedimentation Coefficient

3. Structure Characteristics

3.1 Structure

This centrifuge is composed of main machine, rotor and other accessories (by user's option). And main machine is composed of machine frame, door lid, control panel, drive system, refrigerating system and electric control system.

3.2 Main Frame Shap

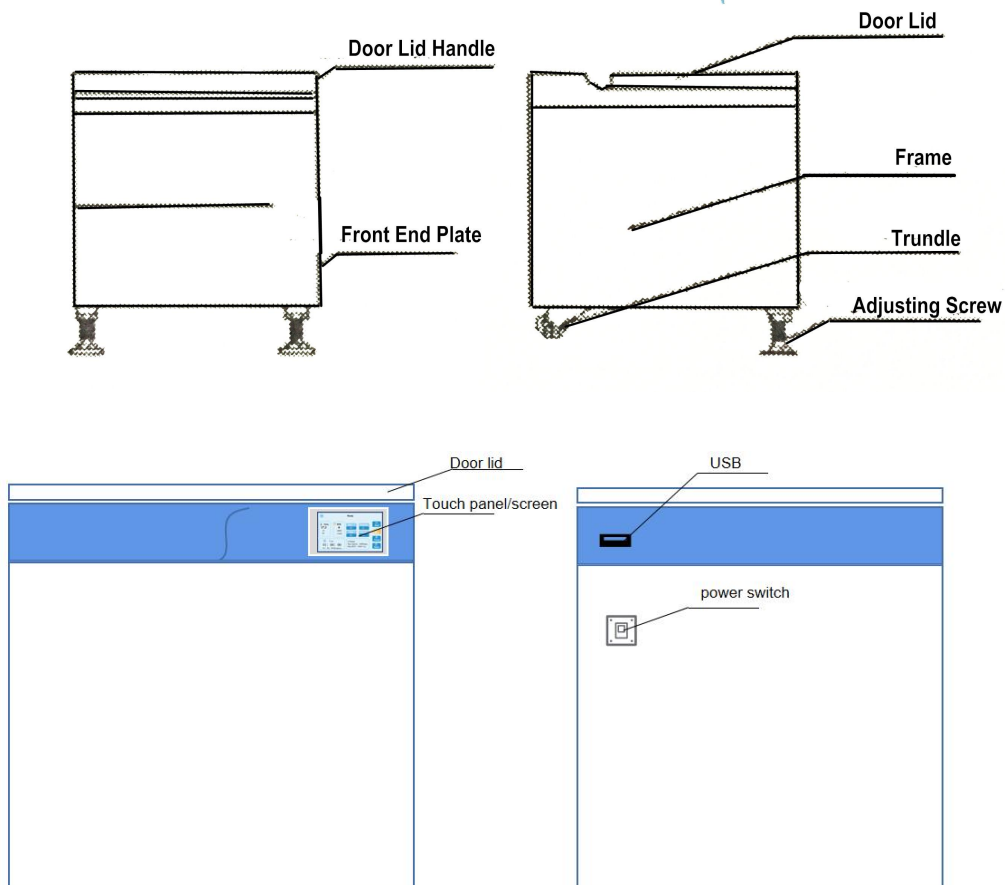

When you need check motor, control board or other parts' working status, please loosen screws below the front end plate firstly and then remove it.

3.3 Drive System

Direct drive system. Frequency conversion motor with high torque is

equipped with special shocking absorber for reducing vibration and noise.

3.4 Refrigeration System

This centrifuge is equipped High-performance compressor, CFC-free refrigeration system. And with two circuit control and start/stop solenoid valve for good efficiency of heating and refrigerating.

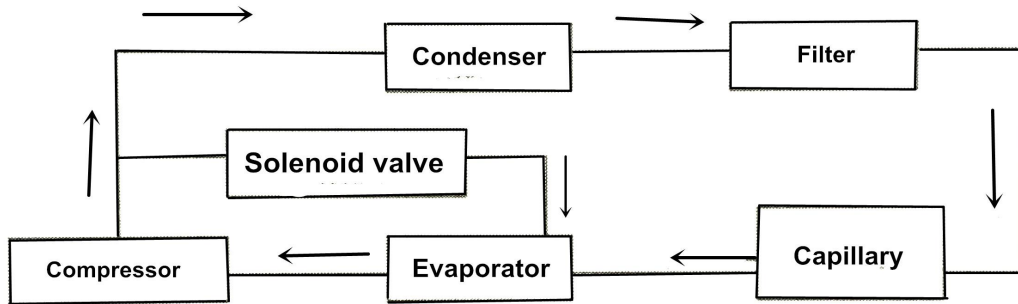

3.5 Electric Control Part

System control is adopted 8-digit CPU. Through sensors CPU detects the temperature in centrifugal chamber, speed and fault signal etc., and compare them with the setup parameters such as temperature and speed, then deal with them correspondingly.

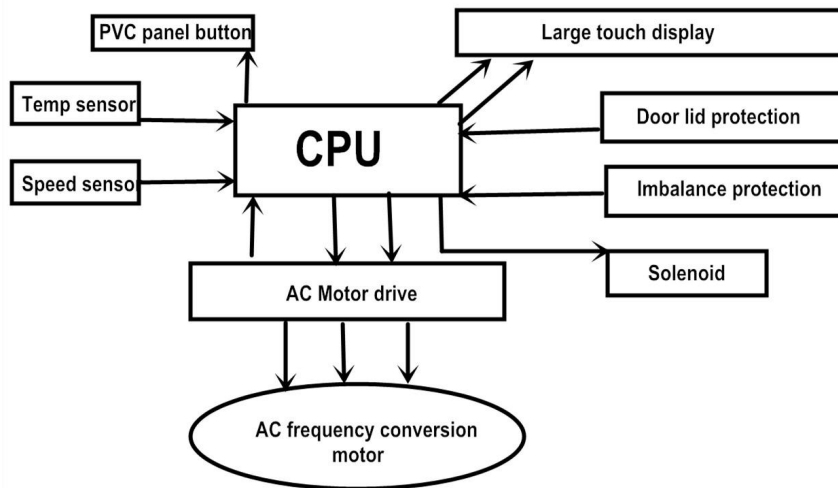

4. Installation and Adjustment

4.1 Unpacking of package

User should check the appearance of packing case after receiving, and the goods should not be happened with sharp hitting and upending during delivery. Please contact with forwarding agent and inform our company immediately if occurring above accidents.

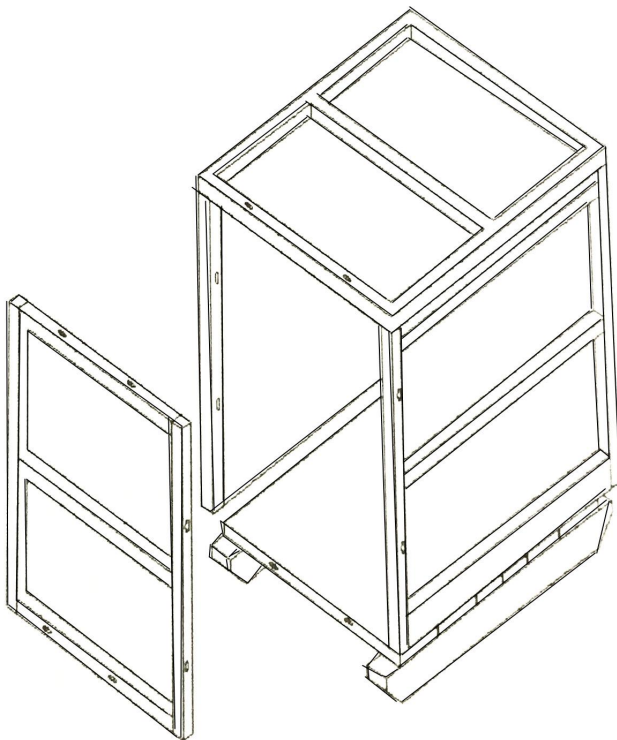

Attention : The idler wheels of this centrifuge can be only moved a short distance on smooth ground for avoiding damage. Be sure to check accessories and packing list after unpacking the case.

4.2 Installation Requirements

 **Warning:** This centrifuge should be installed indoor with steady ground, no conducting dust, no corrosive gas, no strong shocking source and no direct sunlight.

Space requirement:

The distance between centrifuge and wall should be kept 3cm at least for air

circulation. The room temperature should not exceed 35 for the best.

Power requirements:



Warning: The ground wire should be connected properly in case of electric shock.

As for measures, this centrifuge is adopted with single phase and three wires plug to make sure of grounding. If your plug can not plug in the mains jack, please contact the electrician to replay your main jack. Make sure that the centrifuge is grounded properly.

Installation requirements:

Two adjusting screws are located on 2 corners of base board, four feet can be adjusted on floor and universal wheels can be raised 3-5mm by spinning them. Two truckles and two screwing feet should be adjusted until stressed equably.

4.3 Adjusting Requirements

Checking the goods:

Check the packing list the and make sure if damage is occurred during delivery.

Installation , adjustment and maintenance should all be guided or operated by professional technicians.

Door lid opening:

After installing the main machine, check the connection of all connectors and fuses first, and turn on the main switch then. When the screen display model/Logo, and then the main specifications will be showed. Pull the latch on the door lid lock device by manually, and the door lid gradually opens at the holding of gas springs polar and your hands,

Rotor installation:

Rotor should be checked carefully before using. It is forbidden to use rotor and buckets with crack and corrosion spots (especially the buckets bottom of swing rotor). All accessories should not be used if it is exceeding of its service life. The conical surface of driving shaft should be smeared with some lubricating grease if the main spindle is leaving unused.

 **Warning: The conical surface of rotor and driving shaft must be connected closely.**

As shown in the following figure: Firstly clasp the symmetric spoke of rotor, and put it on the rotor base vertically and placidly while the rotor bottom's location cone aims at the location cone of drive shaft; then put the flat gasket on the lead screw and screw down the cap nut. At last, hold up the rotor steadily (not shacking) by one hand, and put the solid wrench on the cap nut by another hand. In the mean while turn the wrench for 3 to 6 rounds in clockwise direction until the rotor connects the drive shaft closely.

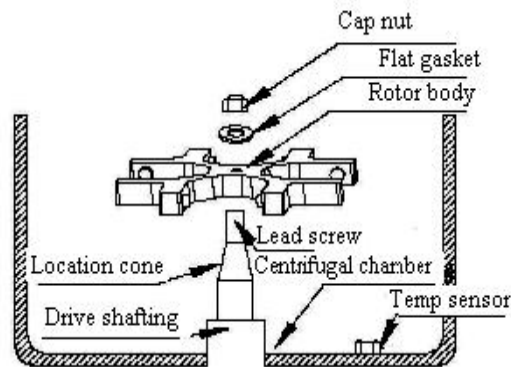

Rotor disassembly: (After finishing adjust or centrifugal)

First clasp the spoke of rotor with one hand, and put the solid wrench on the cap nut by another hand. In the mean while turn the wrench for 3 to 6 round in counter clock wise direction to loose the cap nut until the rotor can be separated from driving shaft. If the rotor is not taken out from the drive shaft for a lone time and blocked, you can beat the surrounding spoke of rotor several

times lightly with wooden or rubber hammer. Then clasp the symmetric spoke of rotor and lift slightly by both hands, and put the rotor on the flat table and ground covered with soft pad.

 **Warning: All actions on the rotor must be soft for avoiding the damage of driving shafting.**

Adjusting level

Take out the gradiometer after rotor installation, open lid of centrifugal chamber and then put it on the rotor bracket. Adjust 2 leveling screws (on the front of baseboard) until the bubbles of any directions are all located in center.

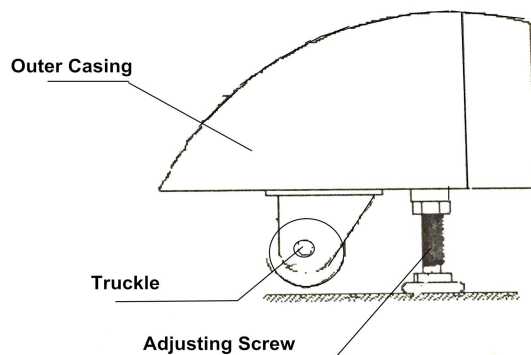

 **Warning: Adjust the screws for instrument leveling; reliable installation can reduce rotor damage.**

Attention: Make sure that 2 back wheels and 2 adjusting screws are all stressed, it is forbidden for hanging. Installation, adjustment and maintenance must be worked by professional technician..

5. operation

5.1 Safety Notice

When the centrifuge is under high-speed operation, a small mistake of operation will cause strong damage of the centrifuge. In order to operate the centrifuge safely, operators should read the instruction manual carefully, and be careful with the following things:

Performance index for main machine

- 1. Pls make sure the machine and rotor balance before operation.**
- 2. Please pre-cooling for more than half hour (Just turn the power on) before operation so that could gain your condition.**
- 3. Heating the centrifuge chamber to 25°C to 30°C for 10 minutes after using (if under low temp.) to keep the chamber and Motor shaft DRY so as to extend the life of the machine.**

1. Forbidden for Artificial over speed

Artificial over speed is a serious violation of operating procedures, very easy to occur personal equipment accidents. Please don't run the centrifuge over the max speed of the rotor.

2. Don't start the centrifuge machine under these conditions:

- a. The rotor is unbalance.
- b. You have not adjust the level of the centrifuge

3. Please don't change or set the fixed value of the inverter.

4. The service life of the rotor: The service life of the rotor is 5 years. The use of cumulative number is 3000 times, the accumulated use time is 2000 hours. One of the three conditions is reached; the duration of rotor 'use is invalid. Prohibit using the rotor with exceeding service life.

5. Please check the rotors if had hair line before use every time. The rotors will crack if using cracked and corrosion sign rotors.

Check rotor carefully before each operation.

Never use rotor with cracking, corrosion sign, and never use expired rotor.

When maintenance, please take off the plug, wait at least 3mins, then open the front cover, otherwise, very easy to occur electric shock.

The rotor should be equipped on the rotor block correctly, make sure transfer

pin gather in upon each other.

6. Instrument repair, you should remove the power plug, wait at least 3 minutes, and then open the front cover, or prone to electric shock.



Note: Separation of the radioactive, toxic or viral substances, response turned around, try cup, hanging baskets, test adapters and other steam sterilization and purification methods in Table 3

Table 3 Time- Temperature Conditions

Absolute Pressure kpa	Corresponding steam temperature		Minimum hold time/ min
	Rated temperature /°C	Range/°C	
225	136.0	134-138	3
150	127.5	126-129	10
115	122.5	121-124	15
75	116.5	115-118	30

Note: The minimum hold time is purification time under temperatures

5.2 Preparation and Installation of the Rotor

- 1). Choose the rotor and centrifuge tubes as the sample.
- 2). Use the double pan balance to balance after the tubes with sample. The difference cant be over 0.5g. Then put it into the centrifugal cup of the rotor in symmetry. The rotor lid should be locked closely.
- 3). The pipe rack of the swing rotor should be put on the rotor block according to the number and tubes should be put in in symmetry. Do not allow the weight of the pipe rack in symmetry not the same with the other pipe rack in symmetry.(if the sample is in low, use other liquid instead).
- 4). Open the centrifuge chamber, clean it.
- 5). Put the rotor into the rotor block reposefully. Pay attention to make transfer pin in the middle of the rotor put into the transfer pin' blank of the rotor block.

Make sure the rotor completely fall, or it is dangerous. Then close the lid of the centrifuge chamber.

5.3 Operation Procedures & Directions

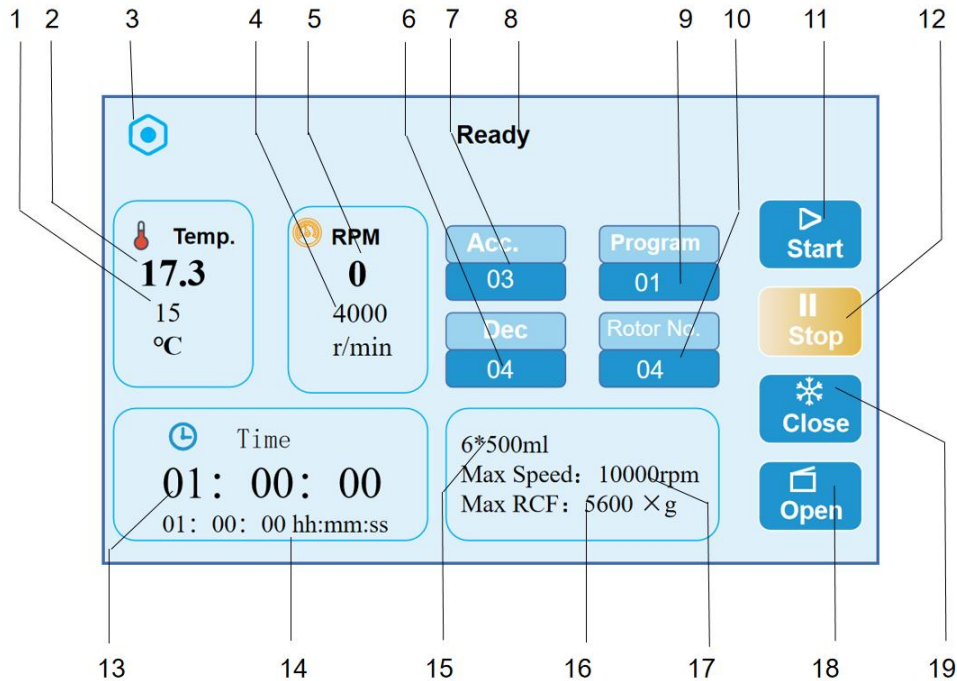

Fig.1 Touch Panel/screen

- 1-Set temperature 2-Real temperature 3-Set up 4-Set Speed
- 5-Real speed 6-Deceration grade 7- Acceration grade 8-Status
- 9-Program memory 10- Rotor No. 11-Start key 12-Stop Key
- 13-Real time 14-Real time left 15-Rotor Capacity 16-Rotor max RCF
- 17-Rotor max speed 18-Open door key 19-Close door key

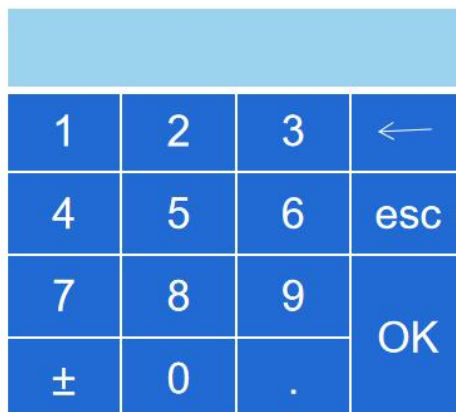

Fig.2 keyboard

5.3.1 Power on

Power switch is located on the right bottom corner of control panel. Turn it to “On” position, the power indicator will turn red.

5.3.2 Parameters setting

1). Temperature Setting

Click the [Temperature] in screen, will show the Fig.2 keyboard. Set the Temperature needed and click {OK} to confirm the setting, or click {esc} to cancel the settings. Compressor will work since machine power on.

2) . RPM Setting

Click the [RPM] in screen, will show the Fig.2 keyboard. Set the RPM needed and click {OK} to confirm the setting, or click {esc} to cancel the settings.

3) Time Setting

Click the [Time] in screen, will show the Fig.2 keyboard. Set the time needed and click {OK} to confirm the setting, or click {esc} to cancel the settings. Cut down timing mode while reach to setting speed.

4) Acceleration /Deceleration Setting

Click the [Acc/Dec] in Screen, will show the Fig.2 keyboard. Set the Acc/dec grade and click {OK} to confirm the setting. There are 1-9 grade, No.1 grade is fastest, No.9 is slowest.

5) Program Memory Setting

Click [Program] in Screen, will show the Fig.2 keyboard. Choose the Prog. Number and then to set other parameters that you need to memory.

6) Rotor No. Setting

Click the [Rotor No.] in Screen, will show the Fig.2 keyboard. Set the Rotor and click {OK} to confirm the setting, if you set wrong number, will correct it after running.

7) Open Door

Click the [open door] icon to open the door lid, for unexpected power off, there is backup power for open door lid.

(note: backup power only for short time use, after unexpected power off, please take out samples ASAP.)

8) Start

Click [Start key] in screen, machine will running and automatic identify the rotor number. Click Start key no use while door lid opening.

9) Stop

After finish running will stop automatically or click [Stop] at any time.

6.Maintenance & Trouble Shooting

We try to reduce the complex work of maintenance and checking in the centrifuge's design. But operator should also maintain daily according to the requirements of "Instruction Manual" for a long-term, safe and efficient work.

6.1 maintenance

1) Maintenance of the centrifuge chamber

Clean the centrifugal chamber time, take out rotor and then scrubbed by cleanly cloth. Put the silica gel bag into chamber if the centrifuge will not be used for a long time to absorb humidity and avoid rust.

2) Maintenance of the rotor

Rotor block can not bump. Do not damage the cone. Clean carefully rotor block and rotor cone with soft cloth before the rotor put in and coated with a little Vaseline or other grease medical.

3) Maintenance of the control box and work surface

Control box and work surfaces must be kept clean. Rotor centrifuge tube and other tools of centrifuge may not be placed on the panel to prevent scratches. Control box and work surface can be only used with a soft cloth and mild detergent.

4) Maintenance of drive shaft

The drive shaft must not be hit for conical surface/cone protection. Use soft cloth to clean the drive shaft and taper hole before rotor installation, and then smear some Vaseline or other lubrication grease.

6.2 Trouble Shooting

1) Common troubleshooting

A. The rotor does not work.

a. If the power light is off, check if the fuse is burned out, whether the power

contact is good.

b. Whether the value set is correct.

c. Whether it is under thermal protection after a long time working.

B. Cooling effect is not good

a. The temperature in the centrifuge chamber is too high.

b. The centrifuge is too close to the wall.

c. Condenser heat sink is blocked by dust or condenser fan is not running.

d. Refrigeration system refrigerant leaks or is mixed with air. Cooling system is blocked or broken.

e. The re-poured amount of refrigerant is too little or too much after repair or refrigerant is not a match.

f. The vibration and noise of the centrifuge increases or sound abnormal.

g. Whether the ground is solid, and whether there are strong availability of source effects.

h. Whether rotor balancing is destroyed.

Whether centrifuge tube is qualified for balance, placing is symmetrical.

i. Whether level did not adjust well, it is with uniform stress.

j. Whether shaft bending jumps too large.

k. In the centrifugal midway, the centrifuge tubes or O-type seal ring broke.

C. The rotor can not be put into the rotor block reposefully.

a. Check rotor and rotor block if there are scars or dirty objects.

b. Whether transfer pin is out of shape.

D. The rotor can not be got out of rotor block.

a. With using the rotor handle screwing into center of the rotor screw, the rotor can be removed.

b. The rotor block cone and the rotor cone coated with a little grease can easily remove the rotor.

c. Do not run for a long time when there is no refrigeration.

Table 4 Trouble reminder and solution

Trouble Reminder	Solution
------------------	----------

The display window not working	Please check whether the power switch is lighten, and if the connect line of display panel is loose.
No Speed	Please check whether the electric connector line of motor is loose, and if the speed sensor is normal.
Over Speed	Turn on again, check whether the speed sensor is normal
Door Unclosed	Please close the door tightly before start
Transducer Communication Trouble	Please check whether the frequency converter is damaged, whether the communication line is connect good
Module Trouble	Please change the control board

7. Transportation and Storage

7.1 Transportation

You should use the wooden case and carton during long-distance transportation. Put centrifuge with dust cap into the case, and fill with foam or plastic shock absorption materials. It is forbidden to be hit, inverted, rolled and soaked by rain and snow.

You can directly move the centrifuge in room, but avoid big vibration, hitting and inversion

7.2 Storage

If the centrifuge is leaving unused for long time, you should open the door lid and store it in ventilated, dry and clean room where is no corrosive, flammable and explosive matters.

The ambient temperature is $-10^{\circ}\text{C} \sim 45^{\circ}\text{C}$, and relative humidity is not over 75%. No corrosive air and well-ventilated indoor.

As the technology continuously renews, please consult us if there is something unconformable with this instruction manual.

Warranty

Respected customers,

Thank you for purchase of our company's product. To protect your legal rights and avoid your worries, we provide warranty service for one year with the main machines. If it is broken under warranty with un-artificial reason, we will supply free maintenance service. The customer needs to pay the prime cost of the product parts if the product has exceeded the warranty period. We will not supply the free maintenance if any following matter is happened:

- 1.Exceed of the warranty period or without the warranty card.
- 2.The trouble is caused by wrong installation, operation and maintenance.
- 3.The trouble is caused by the unauthorized uninstalling and repairing by our company.
- 4.The trouble is caused by using the rotor not equipped with this centrifuge.
- 5.The trouble is caused by war or other irresistible factors.

This centrifuge has been subjected to thorough testing and quality control before delivery. We promise to do as below:

1. One year warranty for this centrifuge (from the date of delivery).
2. Our company after-service center will build up files in time and follow up the user's information.
3. We will offer the replacement parts freely if the centrifuge within warranty

Quality Certificate

Floortype Refrigerated Centrifuge DL-7MC

Capacity : 6×1000ml

Speed : 8000r/min

RCF : 11620xg

Product series number: DW2603XF68

This product is tested and qualified for delivery.

Test Department:

QC:

Date:2023-3-10

Packing List

Ser.No	Description	Quantity	Remark
1	Centrifuge	1set	√
2	Rotor	1sets	√
3	Quality Certificate	1pcs	√
4	Instruction Manual	1pcs	√
5	Packing List	1pcs	√
6	Rotor Handle	1pcs	√
7	Compression Screw	1pcs	

Rotor Option				
Number	Max Speed	Max RCF	Capacity	Option
NO.1 Angle Rotor	8000r/min	11620xg	4×1000ml	
NO.2 Angle Rotor	7000r/min	11500xg	6×1000ml	√

Service Manual

Trouble	Cause	Removal
The display window not working	No 220V power supply; Air switch to transformer is turnoff(rosin joint)	Check power supply
	Power transformer in main board is damaged;Control board has burn out.	Check and replace
	The electrical elements L7812,L7805 of the display board are broken.	Replace
Power switch trips	Error connection;Heavy current component is short.	According solution
	127V power input is short.	Check and repair
Motor running without speed	Speed sensor of motor is damaged.	Replace the sensor
	Check whether 0~5V output of the main board is normal or not.	Replace main board
	The Control mode of invert is through external terminal and frequency is 0~5V.	Reset parameters
	Check connection between control panel and speed sensor.	According solution
The rotor doesn't run after you press the start button	The connection terminal to circuit board is loosened.	Connect it properly
	The control mode of inverter is through external terminal and frequency is 0~5V.	Reset parameters
	Check whether 0~5V output of the main board is normal or not.	Replace main board
Motor is blocked or dithering	Inverter parameters are reset.	Reset
	Rotor is blocked mechanically.	Replace motor
Motor speed is not stable	Voltage fluctuation is frequent;Rotor type is set wrongly.	Replace
	Check whether 0~5V output of the main board is normal or not.	Replace
	Output voltage L7812,L7805 of display board is abnormal.	Reset
	Inverter parameters are set improperly.	Reset
Motor can only run when you move the rotor by hand after starting.	Inverter parameters are set improperly.	Reset
	Check whether 0~5V output of the main board is normal or not.	Replace
	Rotor is blocked mechanically	Replace
LD2 small yellow light	The indicator light of speed sensor:while motor shaft is rotating,the light flashing means the sensor is normal;The light not flashing means the sensor is abnormal.	
LD3 small red light	Main board DC12V indicator light:light on means normal;Light off means abnormal.	
LD4 small red light	The indicator light for door lid doesn't close	

	properly:light on means abnormal;light off means normal.	
LD5 small red light	The indicator light of inverter trouble:light on means abnormal;light off means normal.	
LD6 small green light	The indicator light of inverter start:light on means start;light off means stop.	
LD7 small green light	The indicator light of door lid opening : light on by pressing door opening button;light off without pressing.	
LED4 big green light	The indicator light of CPU running:bright often and flashing once for every second means normal.	
Door lid protection "Er3,Er5"	The door lid isn't close properly.	Close door lid properly
	The sensitive switch of door lid is damaged.	Replace
System failure "Er7"	Press start button to check if the display board voltage from VOUT to AGND is over 1.0V.	Replace main board
	Whether signal connecting wires to inverter is reliable.	Replace
	While motor shaft is rotating,whether LD2 small yellow light is flashing.	Replace speed measuring device
	Inverter parameters are set improperly.	Reset
Error manipulation "Er8"	Re-manipulate until the speed is descended on to 300r/min or set correct parameters.	Wait
Error manipulation "Er9"	Inverter parameters are set improperly.	Reset
	Whether connector is jointed reliably.	Replace
	Inverter is damaged.	Replace
Temperature display window always show "0.0" error	Temperature display window always show"0.0":if you touch closely the temperature sensor in centrifugal chamber without changing display window or the actual temperature in centrifugal chamber has changed while temperature display window always show"0.0",we judge the temperature sensor or main board damaged.	Replace the sensor or main board
	While the centrifuge is in single heating/cooling status for a long time,the actual temperature in centrifugal chamber will be over the temperature accuracy controlling range.	

Drawell International Technology Limited
Chongqing Drawell Instrument Co., Ltd.
Shanghai Drawell Scientific Instrument Co.,Ltd.

Chongqing Center : Suite 2204,Building No.11,Shiyou Road No.1,
Yuzhong District, Chongqing China.

Shanghai Office : Suite 1117,Lane561 XiuChuan Rd.,PuDong New
Area,Shanghai,China

Homepage : www.drawell.com.cn

Tel : 0086-023-63268643

Email : sales05@drawell.com.cn