

CS-8820T Carbon & Sulfur Analyzer User Manual



Please read operating manual before installation and operation.

Drawell International Technology Limited

Chongqing Drawell Instrument Co., Ltd.

Shanghai Drawell Scientific Instrument Co., Ltd.

Address : Suite 2204, Building No.11, Shiyou Road No.1, Yuzhong District,
Chongqing China.

Homepage : www.drawell.com.cn

Tel : 0086-023-63268643

Email : sales05@drawell.com.cn

Contents

Chapter 1 General Introduction.....	1
1.1 Application.....	1
1.2 Component.....	1
1.3 Technical Index.....	1
1.3.1 Range of Measurement.....	1
1.3.2 Repeatability.....	1
1.3.3 Indication Error.....	1
1.4 Technical Requirements.....	2
1.4.1 Working Gas.....	2
1.4.2 Gas Flow.....	2
1.4.3 Chemical Reagent.....	2
1.5 Basic Working Principle.....	2
1.5.1 The Principle for Infrared Testing Principle.....	2
1.5.2 High-Frequency Heating Principle.....	3
1.5.3 Working Principle for HF Induction Circuit.....	4
1.5.4 Working Principle of Gas Path.....	5
1.5.5 The Full-frame Working Principle.....	5
Chapter 2 Instrument Construction	8
2.1 Electronic Balance.....	8
2.2 Computer.....	8
2.3 Infrared Host.....	8
2.3.1 Front View.....	8
2.3.2 Left View.....	10
2.3.3 Right View.....	11
2.3.4 Rear View.....	12
2.3.5 High-frequency Induction Furnace.....	12
Chapter 3 Installation of Instrument.....	14
3.1 Preparation before the installation.....	14
3.1.1 Working Environment Requirements.....	14
3.1.2 Power Supply.....	14
3.2 Instrument Computer Installation.....	14
3.2.1 Installing an electronic balance.....	14
3.2.2 Installing the computer.....	16
3.2.3 Installing the electronic tube.....	18
3.2.4 Installation of burner system and combustion tube.....	19
3.2.5 Installation of reagents.....	22
3.2.6 Signal pool installation.....	23
3.2.7 Installation of gas path.....	25
Chapter 4 System Installation and Analysis Software Features.....	26
4.1 Software Introduction.....	26
4.2 Analysis Software Installation.....	26
4.3 System Build Mode.....	26

4.4 Analysis Software Main Interface.....	26
4.4.1 Color Display Rule.....	27
4.4.2 Alarm Display.....	28
4.5 Weight Operation.....	28
4.6 Analysis Operation and Display.....	28
4.6.1 Conditions and Operations Required to Enter the Analysis State.....	28
4.6.2 Analysis Process Display.....	29
4.6.3 Interrupt Analysis or Pause Analysis.....	29
4.6.4 Storage, Printing and Saving after the End of the Analysis Process.....	29
4.6.5 Real-time Curve Display and Storage.....	30
4.7 Analysis Software Function.....	30
4.7.1 Channel Selection and Channel Parameter Modification.....	31
4.7.2 Results.....	31
4.7.3 One-point Calibration.....	32
4.7.4 Multi-point Calibration.....	33
4.7.5 Current Curve Display.....	34
4.7.6 Curve Reproduction.....	34
4.7.7 Gas Path.....	35
4.7.8 Blank Calibration.....	35
4.7.9 Result Query and Print.....	36
4.7.10 Analyze Data to be copied from the Computer.....	36
4.8 The Principle of Parameter Setting.....	36
4.8.1 Pre-blowing Oxygen Time.....	36
4.8.2 Shortest Analysis Time.....	37
4.8.3 Longest Analysis Time.....	37
4.8.4 The Working Time of High Frequency Furnace.....	37
4.8.5 Up to Level.....	37
4.8.6 Coefficient Calibration.....	39
4.8.7 Blank.....	39
4.8.8 Standard Value.....	39
Chapter 5 Instrumental Analysis Operation.....	40
5.1 Analysis Preparation.....	40
5.1.1 Porcelain Crucible.....	40
5.1.2 Flux.....	40
5.1.3 Standard Material.....	41
5.1.4 Sample Preparation.....	41
5.1.5 Reagent.....	41
5.1.6 Power Supply.....	41
5.1.7 Oxygen Supply.....	41
5.2 Boot Step.....	42
5.2.1 Power Ups.....	42
5.2.2 Oxygen.....	42
5.2.3 Inspection Reagent.....	42
5.2.4 Cleaning Dust.....	42

5.2.5 Check the Working Status of the Instrument.....	42
5.2.6 Analysis Condition Setting.....	43
5.3 Analysis Process.....	44
5.3.1 Sample Weighing.....	44
5.3.2 Porcelain Crucible.....	44
5.3.3 Start Analysis.....	44
5.3.4 Cleaning the Burner.....	44
5.4 Analysis Routine.....	44
5.4.1 How to Analyze a Sample.....	44
5.4.2 One-point calibration operation.....	48
5.4.3 Multi-point calibration operation.....	49
5.4.4 Linear coefficient calibration operation.....	51
5.4.5 Daily maintenance.....	52
5.4.6 How to Analyze Unknown Samples.....	53
5.5 Analytical Experiment.....	54
5.5.1 Calibration Test.....	54
5.5.2 Method Test.....	54
5.5.3 Analysis and Judgment.....	56
Chapter 6 Maintenance and Simple Fault Diagnosis.....	57
6.1 Replacement Reagent.....	57
6.2 Cleaning Filter Screen and Infrared Analysis Chamber.....	60
6.3 Change the reagent.....	66
6.4 Leak inspection.....	68
6.5 Adjust Carbon and Sulfur Voltage.....	72
6.7 Failure Phenomenon and Cause.....	73
6.8 Frequently-used consumable items.....	74

Chapter 1 General Introduction

1.1 Application

CS analyzer Infrared Carbon & Sulfur Analyzer is made up of High-frequency Induction Combustion Furnace and Computer. It can determine the quality fraction of carbon and sulfur contained in steel, iron, alloy, non-ferrous metal, cement, ore, activator, glass, ceramic and other materials rapidly and accurately. This set of equipment is the high-tech product integrating optical, mechanical, electronic, computerization and analytical technologies. It characterizes itself in having wide range of measurement, precise and reliable results of analysis and the like advantages. Due to application of computerized technology, it has so far reached the advanced level domestically in respect to intellectualization of the instrument, the screen display of images and graphs, and collection and processing of data. It can be regarded as an ideal analyzer for various sectors to determine carbon and sulfur contents.

1.2 Component

CS analyzer Infrared Carbon & Sulfur Analyzer consists of balance, all-in-one high – frequency induction heating, computer, and printer.

1.3 Technical Index

1.3.1 Range of Measurement:

Carbon: (0~10)% (extendable to 99.99%)

Sulfur: (0~1)% (extendable to 99.99)

Sample weighing: 0.2g~0.5g

1.3.2 Repeatability

Analyzer repeatability is expressed in terms of relative standard deviation (RSD)

Carbon RSD: $\leq 0.5\%$

Sulfur RSD: $\leq 1.5\%$

1.3.3 Indication Error

For different measurement ranges, the difference between the measured average value and the standard value (the indication value error) shall not exceed the following table.

Indication Error

Carbon(%)	Indication Error(%)
>0~0.0100	±0.0005
>0.010~0.100	±0.005
>0.100~1.00	±0.010
>1.00~4.00	±0.03
>4.00~10.00	±0.07
Sulfur(%)	Indication Error(%)
>0~0.0100	±0.0005
>0.010~0.050	±0.003
>0.050~0.100	±0.004
>0.100~1.00	±0.020

Minimum reading: 0.00001%

Sensitivity: 0.00003%

Balance weighing range: 0.001-100g

Analysis time: 25~60s (Adjustable), usually 35s

1.4 Technical Requirements

Environment: (15~30)°C

Relative humidity: ≤ 60%

Power supply: voltage 220V±10%, frequency: 50Hz ± 2%,

Power: 5KVA, grounding resistance ≤ 4Ω, combustion power > 2.5KVA

1.4.1 Working Gas

Oxygen purity ≥ 99.5%, oxygen cylinder pressure > 0.5Mpa

Input pressure: 0.18Mpa, oxygen carrying pressure: 0.08Mpa

1.4.2 Gas Flow

Top oxygen flow: 1.0~2.0L/min Analysis gas flow: 3.0~4.5L/min

1.4.3 Chemical Reagent

Efficient color changing desiccant, high efficiency carbon dioxide absorber(Alkali asbestos)

1.5 Basic Working Principle

1.5.1 The Principle for Infrared Testing Principle

The gaseous molecules CO₂ and SO₂ placed in the infrared waveband have selective absorption spectra. When going through CO₂ and/or SO₂ gases, the infrared rays of certain wave length can have strong capacity of light absorption, of which the regularity can be obtained from Lambert-Beer's Law.

$$I_o(\lambda) = I_i(\lambda) \cdot (-\alpha(\lambda)CL) \dots \dots \dots (1)$$

Since it is available for the detector to convert the light signal into the electric signal,

Formula (1) could be expressed in another way as follows:

$$V_o(\lambda) = V_i(\lambda) \cdot (-\alpha(\lambda)CL) \dots \dots \dots (1)$$

In which, $I_i(\lambda)$ and $V_i(\lambda)$ represent respectively the incoming light intensity of the specific wavelength λ and the electric signal value thereof.

$I_o(\lambda)$ and $V_o(\lambda)$ represent respectively outgoing light intensity after the absorption cell and the electric signal value thereof.

$\alpha(\lambda)$ represents the absorptance index of the testing gas in the specific wave length λ .

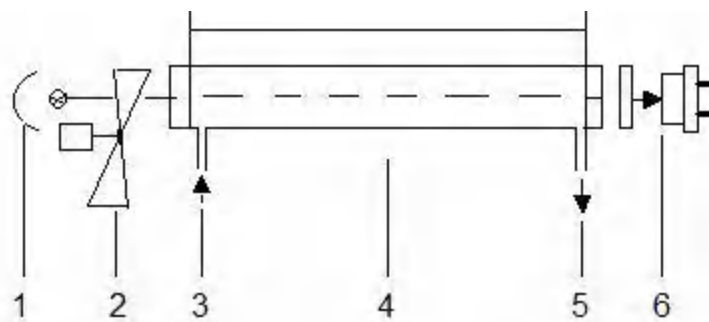

Fig.(1) Route Chart of Analysis Cell

- 1 Light source 2 Chopper 3 Infrared window
- 4 Absorption cell 5 Light filter 6 Detector

It is comprehensible from the aforesaid formula that as one specific wave length is chosen and the analytical (absorption) cell length is determined, the concentration of the testing gas contained in the mixed gases can be converted from the light intensity measured. That is the basic principle for the quantitative determination of the gas concentration with the infrared absorption method. Selected for this type of measuring instrument, the wavelength of CO₂ is 4.26 μm and that of SO₂ is 7.4 μm.

1.5.2 High-Frequency Heating Principle

According to Faraday law of electromagnetic induction, as being placed in the HF alternating field, the metal conduct will produce from inside the induction electromotive force, as a result of its low resistance, will generate powerful induced current. It is known from Joule-Lenz's law that the alternating magnetic field shall cause the current in the conduct flow toward the metal surface so as to create the skin effect, the density of the instantaneous current is proportional to the frequency, the higher the frequency is, the more density of the induced current would concentrate on the surface, or in another word, the skin effect would be more intensive. The conduct will be heated rapidly as the valid conductive area is decreased but the resistance is increased.

1.5.3 Working Principle for HF Induction Circuit

After switching on the power on the panel, the 220V AC voltage will be divided into three routes by way of LBI Power Wave Filter before supplying the whole system separately: the first one will be supplied to the axial fan F through LB2, the second will be supplied to the filament transformer T2 and the third will be supplied to the HV circuit through the control of the solid-state relay K2. After the switching the High-frequency, and the solid-state relay K2 is turned on, the 220V AC voltage will be input to the step-up transformer at its primary step and then the high voltage from the output of its secondary step will be rectified by V1~V4 HV rectistack into the DC high volt before supplying the anode of the oscillator when a tank circuit can be formed by C3, C4 & L2 so as to initiate the process of combustion and heating. By adjusting the grid potentiometer W can the grid current be changed so that alteration of the negative feedback would thus be possible. At the end of the set time limit of combustion, the power will be cut off automatically and the process of combustion will be ended. The schematic wiring diagram (2) can be reviewed for details.

In addition, the electric circuit is equipped with the protector against over current and over time. The circuit will cut off the HV power and give the alarm automatically if anodic current exceeds 0.7A or the time of combustion exceeds 1 minute. Push “Rest” button on the lower board to call off the alarm and restore the original condition of operation, the machine can continue to work after proper treatment.

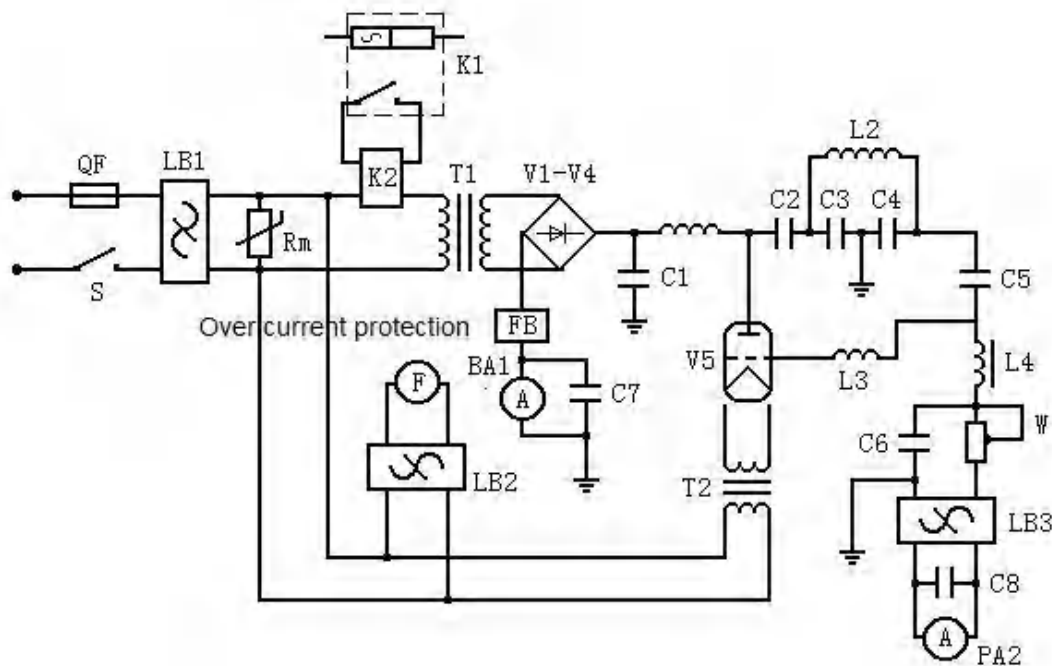

Fig.(2)—Schematic wiring diagram

1.5.4 Working Principle of Gas Path

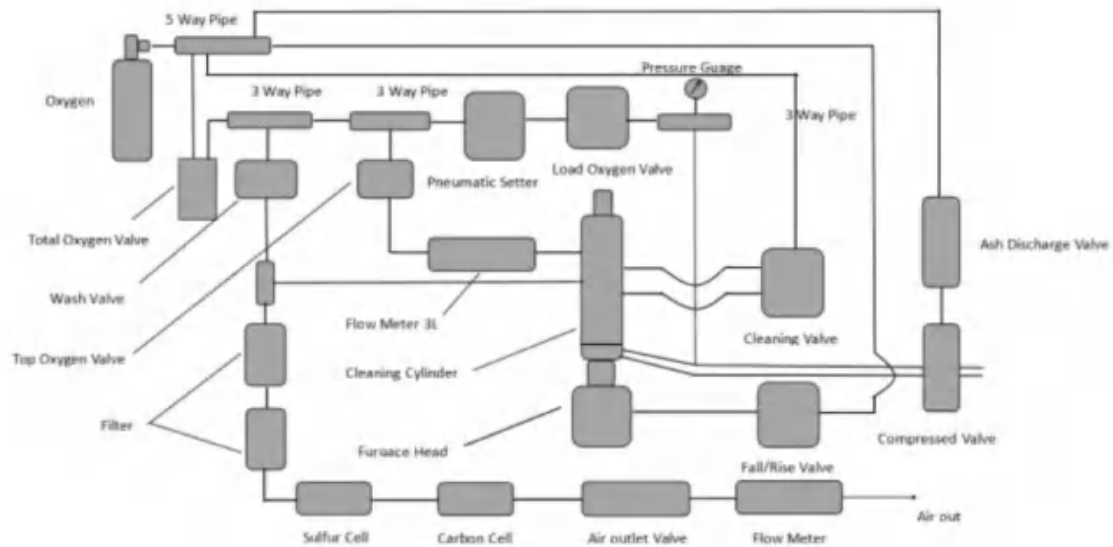

Fig.(3) Schematic diagram of gas path

Refer to Figure (3) for its working principle. The oxygen from the reduce valve of its cylinder with a regulated pressure at 0.18-0.2Mpa (1.8~2.0kg/cm²) is supplied to the instrument for combustion while nitrogen or oxygen is used as the power gas.

One route of the power gas passes by the hold-down valve to compress the ash ejecting pipe. One route supplies auto cleaning equipment to clean quartz pipe by the way of auto cleaning valve, and is supplied as the force to uplift and descend the cylinder by the way of lifting valve.

Having passed the master valve for oxygen, the combustion-oriented gas is divided into two routes: one is to be regulated by 0~3 l/min flow meter before supplying to the top blow of oxygen, in case of cleaning the filtration screen, the gas can be used by way of the purge valve for deducting, the other is to be regulated by the value stabilizer. The purpose of using the value stabilizer is to keep fixed pressure inside the combustion chamber. After the sample is heated and combusted with oxygen, the mixed gas thereof will be deducted with the absorbent cotton and dehydrated with the desiccant before being led into the sulfur cell by gas room inlet valve, then it will enter the carbon cell by the way of transform furnace, metal cotton, 0-5L/min flow meter, and at last it will release through the gas room outlet valve after the 0-5L/min flow meter defines the real rate of flow of it.

1.5.5 The Full-frame Working Principle

The block diagram is to be seen for the full-frame working principle. Figure 4 is divided as the upper, middle and bottom parts. The upper part is the gas path system where each arrow indicates the direction of the gas flow. The middle part is an outline with dotted line reflecting the whole process of transference from the light signal to the electric signal inside the gas analysis room indicated by arrows. The bottom is the circuit system.

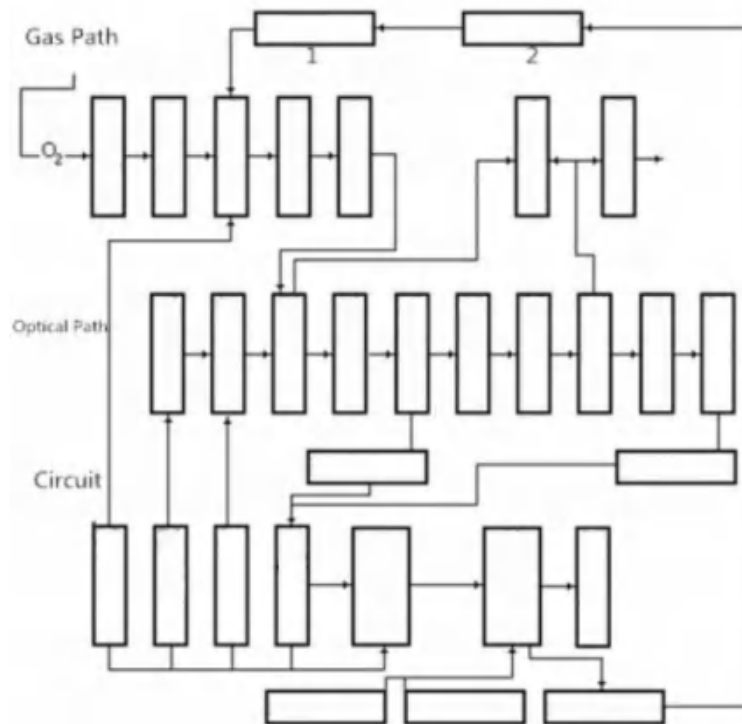

1	2	3	4	5	6
H-F Induction Furnace	Valve Control	Purifier	Constant Voltage Power	Combustion Chamber	Filter
7	8	9	10	11	12
Drier	Absorbing Cotton	Flow meter	Optical Source	Light Chopper	Sulfur Cell
13	14	15	16	17	18
Light Filer	Detector	Optical Source	Light Chopper	Carbon Cell	Light Filer
19	20	21	22	23	24
Detector	Amplifier	Amplifier	Electronic Balance	Constant Voltage Power	Driver
25	26	27	28	29	30
A/D SHIFT	Sampling Testing	Microcomputer System	Printer	Keyboard	Mouse
31					
On/Off Control					

CS analyzer Carbon & Sulfur Analyzer utilizes the characteristics that CO₂ and SO₂ have strong absorption bands at 4.26μm and 7.4μm, respectively. It measures the percentage change of CO₂ and SO₂ gas by measuring the change of light intensity after gas absorption, and indirectly determines the percentage of carbon and sulfur in the sample to be tested.

The analysis chamber includes infrared source, reflector, modulation disk, absorption cell, light filter, and detector. The infrared spark source is electrically heated to about 800° C to generate infrared radiation. The modulator modulates the optical signal into

an 80 Hz alternating radiation signal and enters the absorption cell. The infrared light is absorbed by the CO₂ and SO₂ gases in the absorption cell, and then filtered by a narrow band filter to remove energy of other optical radiation outside the above wavelength. When light is incident on the detector, the light intensity corresponding to the CO₂ and SO₂ gas concentrations is measured on the detector. It needs to be photo electrically converted into electrical signals by the detector to output an analog signal. After A/D analog-digital conversion, the integral is inserted into the percentage of carbon-sulfur element by normalization. The analysis process is as follows: the weight of the sample is first weighed on the electronic balance during the analysis, and input into the microcomputer, or input through the keyboard, and the flux is added to the combustion chamber of the H-F induction furnace combustion chamber. When starting the analysis, the first stage is Oxygen blowing stage, first of all, to turn on corresponding solenoid valve, then according to the analysis process, oxygen is passed through, and the purpose is to remove residual CO₂ and SO₂ gas in the pipeline. When the CO₂ and SO₂ gas content is zero, the measured partial pressure P of the gas is zero. At this time, the signal is the pure oxygen condition reference signal V₀. The second stage is the analysis release phase, to turn on the H-F induction furnace and heat the sample to release the temperature. At this time, the sample is immediately oxidized to form CO₂ and SO₂ gas under the conditions of temperature and oxygen enrichment. Oxygen is used as carrier gas to be transported to the absorption cell, and the output signal of the amplifier decreases as the concentration of the gas to be measured increases. After normalization, we need to make calibration according to every data.

After the analysis, the linear calibration data is subjected to area integral, multiplied by the coefficient, and the blank is subtracted to obtain the percentage of carbon and sulfur in the sample.

Chapter 2 Instrument Construction

CS analyzer Carbon & Sulfur Analyzer consists of balance, the analysis host (it consists of H-F induction furnace, infrared gas detection, and pneumatic system), computer, and printer. Each part is connected by a corresponding cable or pneumatic pipe, they respectively perform weighing (weight input), combustion (oxidation release of C and S elements), detection, data processing, and data(report) printing of the sample to be tested.

2.1 Electronic Balance

CS analyzer Carbon & Sulfur Analyzer detects the weight percentage of carbon and sulfur in the substance, when weight normalized data processing, the sample weight data to be tested is completed by an electronic balance. The weight data is automatically input into the upper computer directly from the balance serial communication port. The measured object is weighed and burned in the porcelain crucible. First of all, putting the processed porcelain crucible on the electronic balance, with the support of analysis software, first removing the weight of porcelain crucible, and then put the tested material into the porcelain crucible, after the balance is stable, press the print button to measure the weight of the item and automatically enter the computer.

2.2 Computer

The computer performs functions such as data acquisition, arithmetic processing, database management, real-time control, man-machine dialogue, and peripheral operations such as printers, electronic balances, and data transmission in the instrument. The computer consists of a host, a display, a keyboard, and a mouse. It needs to be equipped with two serial ports. CS analyzer Carbon & Sulfur Analyzer analysis software requires windows system support, and the analysis software is installed in the D or C root directory.

2.3 Infrared Host

Infrared host consists of high frequency heating system, pneumatic system, carbon and sulfur signal detection system and control system, the sample to be tested is heated and burned to release the CO₂ and SO₂ measurement gases, and is removed by dust removal and sent to be detection system.

2.3.1 Front View

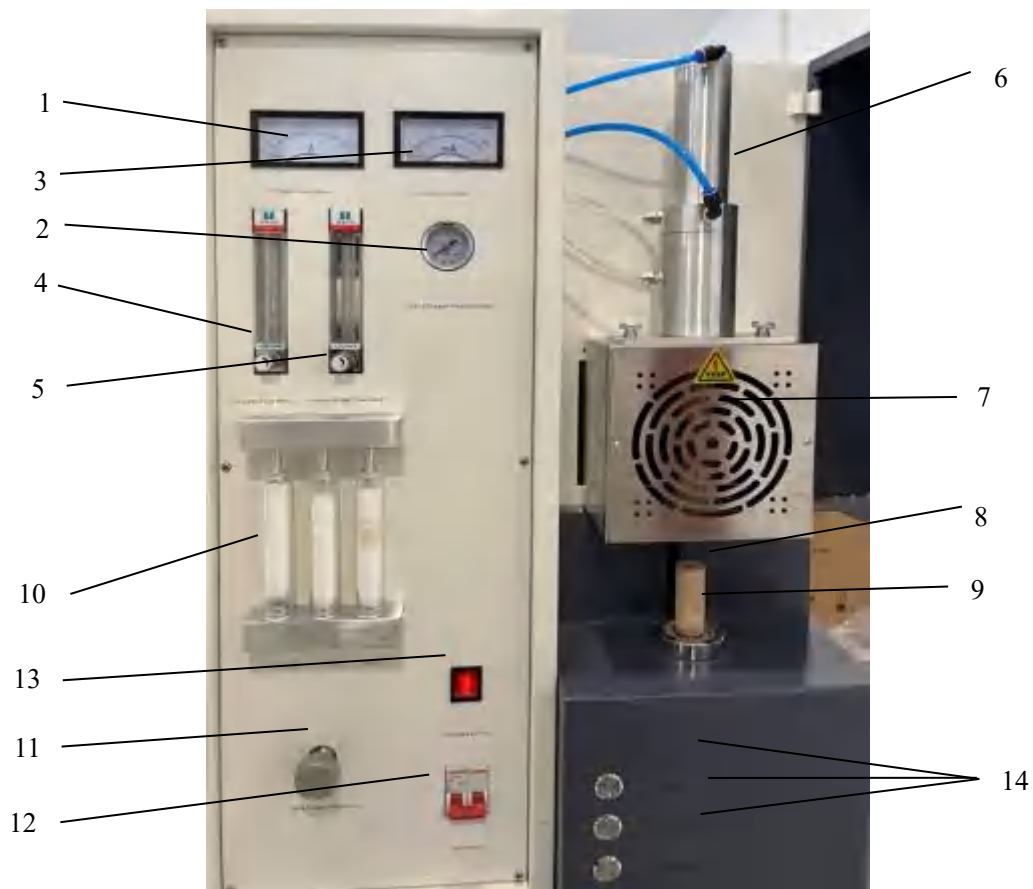

Fig. 1 Infrared Host

1. Anode Current Meter	2. Carry Oxygen Pressure Meter	3. Grid Current Meter
4. Oxygen Flow Meter	5. Analytical Gas Flow Meter	6. Cleaning System
7. High Frequency Induction Coil	8. Quartz Supporting	9. Copper Crucible Supporting
10. Purification Tube	11. Valuator	12. High Frequency Switch
13. Infrared Switch	14. Control Switch	

2.3.2 Left View

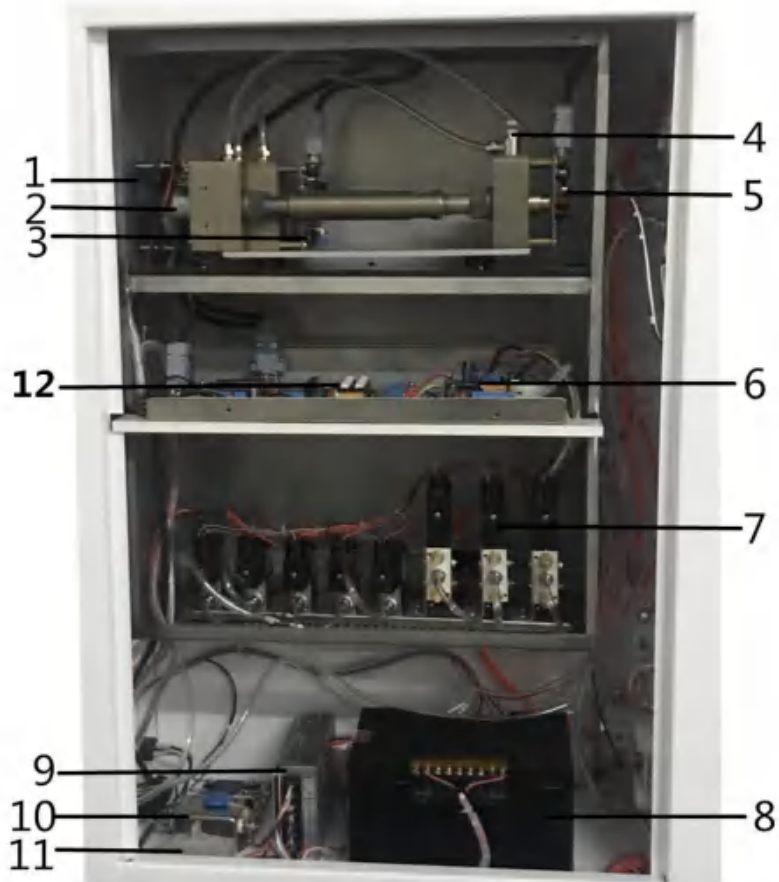

Fig2. Left View of Infrared Host

1. Infrared Analysis Chamber	2. Infrared Motor	3. Carbon Signal Board
4. Flow controller	5. Sulfur Signal Board	6. Over-current Control Board
7. Solenoid Valve	8. Linear Regulated Power Supply	9. Solenoid Valve Power Supply
10. Wave Filter	11. Insurance Holder	12. Infrared Main Control Board

2.3.3 Right View

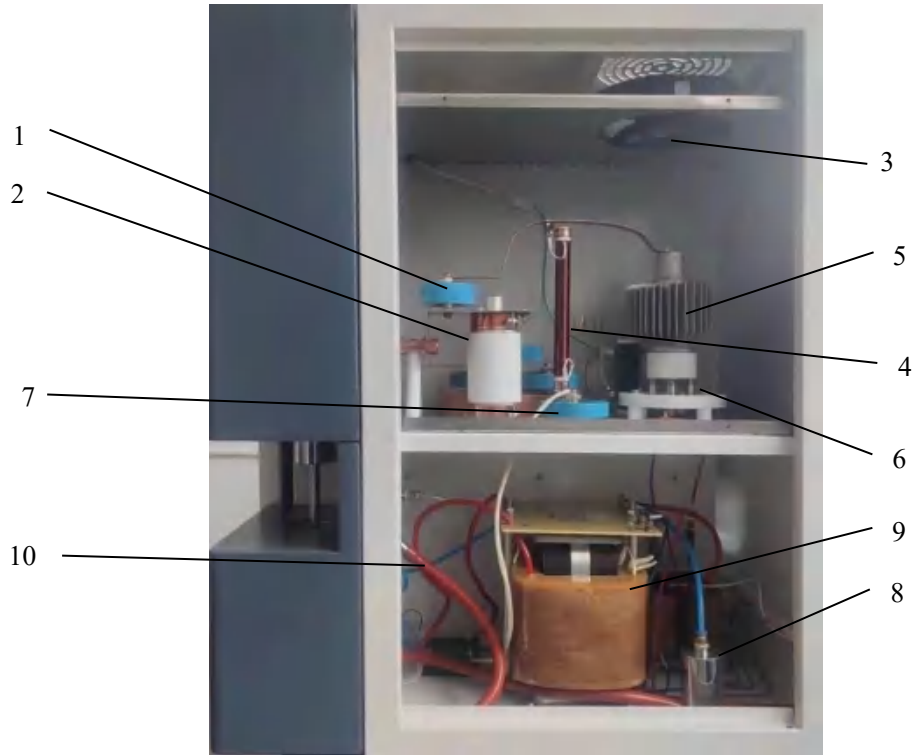

Fig. 3 The Right View of Infrared Host

1. 100P High Frequency Capacitor	2. 100P 100P High Frequency Vacuum capacitor	3. 220V Cooling Fan
4.High Frequency Inductor	5. Electronic Tube	6. Tube Holder
7. High Frequency Filter Capacitor	8. Ash Discharge Valve	9. High Frequency Transformer
10. Ash Discharge Tube		

2.3.4 Rear View



Fig.4 The Rear View of Infrared Host

1. 220V Power Plug	2. 232 (9 Pins) Communication Interface
3. Gas Chamber Outlet	4. Total Oxygen Connector
5. 232 (9 holes) Balance Interface	

2.3.5 H-F Induction Furnace

This device is mainly composed of a high frequency oscillation source, a high voltage power supply, a burner dust removal device and a control device. The sample to be tested is heated and burned to release CO₂ and SO₂ gas, and is sent to infrared detection after being dusted and dried.

(1) Composition of H-F Induction Furnace

The sample is heated and melted by the H-F Induction furnace to release CO₂ and SO₂ analysis gas.

Its composition is: ①high frequency equipment power supply and filter components, ②high voltage power supply, ③ high frequency oscillating circuit(closed metal case)

(2) High Frequency Oscillation Circuit

Main vibration circuit: they mainly consist of 9 high-frequency tube, 4 vacuum capacitor, and Induction coil. And main vibration circuit and grid plate feedback voltage coupling capacitor form a three-point oscillating system of capacitors.

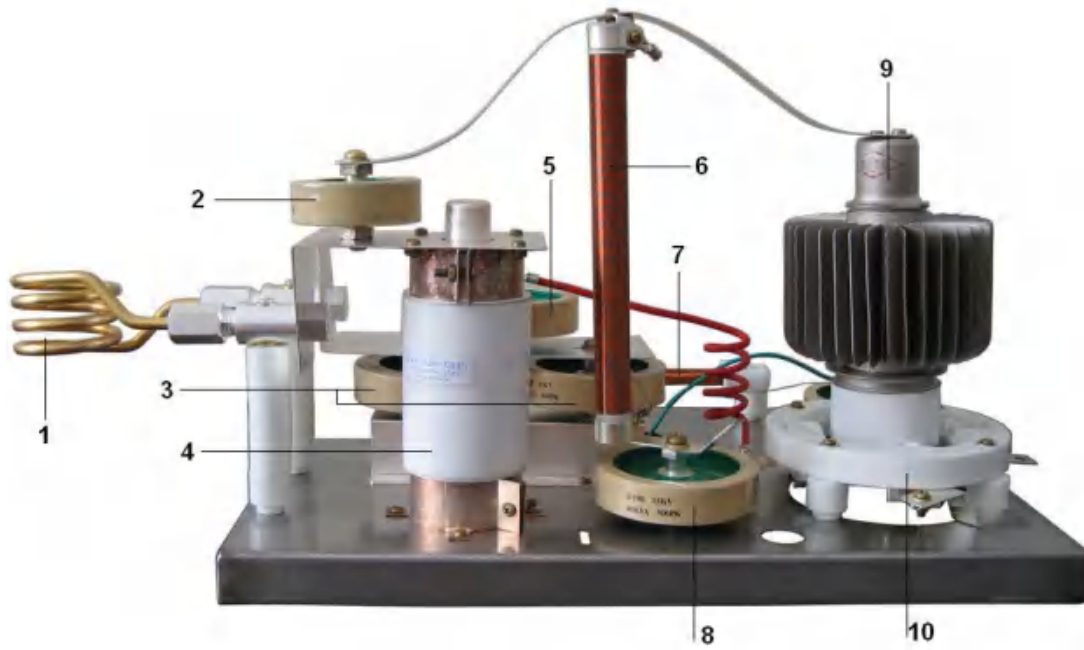

1	2
High-frequency Heating Coil	Coupling Capacitor
3	4
Capacitor Bank of Main Oscillation Circuit	Vacuum Capacitor
5	6
Grid Plate Feedback Voltage Coupling Capacitor	Plate Electrode Choke Coil
7	8
Grid Plate High-frequency Choke Coil	Filter Capacitor
9	10
High-frequency Oscillation Tube	Electron Tube Socket

Chapter 3 Installation of Instrument

3.1 Preparation before the Installation

Note: the user should make appropriate working preparation before the arrival of company installation staff.

3.1.1 Working Environment Requirements

1. Analyzing room: be far away from the erosion gas such as acid, alkali, dust, vibration, testing disturbance.
2. Workbench: stable, approximately 30-50 cm away from the wall: Length × width × height (minimum) : $(1.6\sim 1.8)*0.8*(0.5\sim 0.6)$
3. Environment temperature: $(15\sim 30)^{\circ}\text{C} \pm 2^{\circ}\text{C}$
4. Relative humidity: $\leq 60\%$

3.1.2 Power Supply

1. Voltage: $\text{AC}220\text{V} \pm 5\%$, $50\text{Hz} \pm 2\%$, Power: 5Kw,
2. Voltage stabilizing equipment: Power 5Kw, Voltage stabilizing precision $< 2\%$
3. Working gas: Oxygen purity $\geq 99.5\%$

3.2 Instrument Component Installation

3.2.1 Installing an electronic balance

Step 1 Find the balance related accessories, as shown in Figure 3-1:



Figure 3-1 Balance Accessories

Step 2 Insert the two wires into the corresponding sockets, as shown in Figure 3-2:



Figure 3-2 Sockets behind the balance

Step 3 Power on the balance's power cord, and connect the other end of the signal cable to the COM2 port of the computer, as shown in Figure 3-3:



Figure 3-3 COM2 port

NOTE:

In general, the balance is debugged at the factory. If the customer wants to change to their own balance, they may need to change the baud rate of the balance, as follows:
Step 1 Open the software, click "System", "Instrument Setting", enter the password "QRGs" to enter the setting interface, change the baud rate of the balance (1200, 2400, 4800, 9600), you can try one by one, as shown in Figure 3-4:

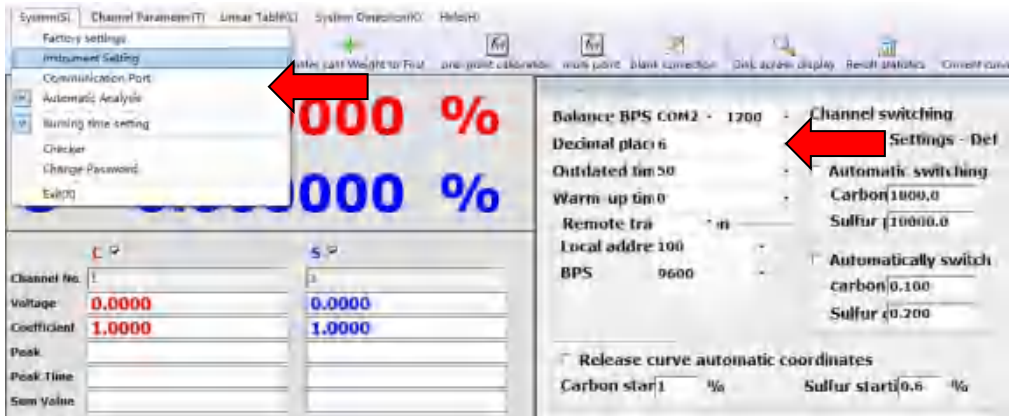

Figure 3-4 Instrument Setting

Step 2 Select a baud rate each time, click "OK", press the print button on the balance, and observe whether the computer's weight list automatically displays the weight (if the balance has weight data), as shown in Figure 3-6:

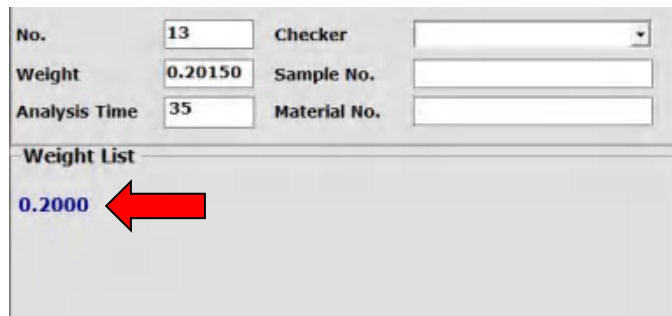

Figure 3-5 Weight display

3.2.2 Installing the computer

Step 1 Connect the host computer and the screen as required;

Step 2 Connect the signal line of the infrared detection and analysis cell to the computer COM1 port, and the other end to the instrument host, as shown in Figure 3-7:



Figure 3-6 COM1 port

NOTE:

Generally, the COM1 and COM2 ports are automatically connected. If an abnormality occurs and the balance port cannot be connected, you need to perform the following operations to check whether the connection is normal.

Step 1 Open the computer software, and then click "System" and "Communication Port", as shown in Figure 3-7:

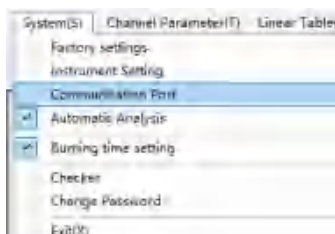

Figure 3-7 Communication port settings

Step 2 Enter the setting interface, change the two ports to each other and click "OK", as shown in Figure 3-8:



Figure 3-8 Communication port

Step 3 Check whether the signal cable is normal again and wait for the software to connect automatically until normal.

3.2.3 Installing the electronic tube

Step 1 Open the right side of the instrument, as shown in Figure 3-9:



Figure 3-9 Opening the side panel

Step 2 Find the tube and observe the four columns of the base corresponding to the

instrument, as shown in Figure 3-10:

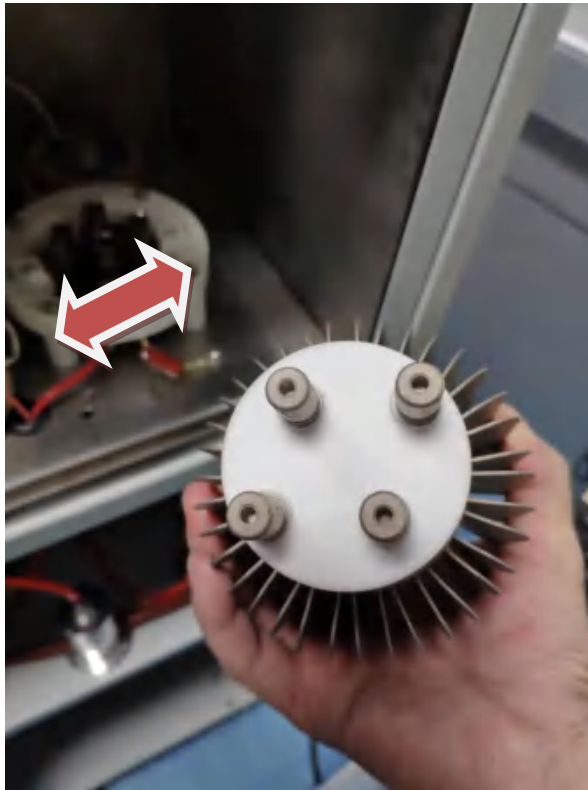

Figure 3-10 Electronic tube base

Step 3 Install the tube on the instrument, paying attention to the corresponding position, as shown in Figure 3-11:



Figure 3-11 Electronic Tube

Step 4 Tighten the connection above the tube, as shown in Figure 3-12:



Figure 3-12 Upper part of the tube

3.2.4 Installation of burner system and combustion tube

Step 1 Open the front cover of the high frequency furnace and place the quartz combustion tube into the upper end of the combustion chamber, as shown in Figure 3-13:



Figure 3-13 Installing a quartz burner tube

Step 2 Install the burner on the combustion tube and fix it, as shown in Figure 3-14:



Figure 3-14 Installing the burner

Step 3: Connect the corresponding cleaning cylinder and air supply pipe, as shown in Figure 3-15:



Figure 3-15 Air connection

Step 4: Place the elliptical seal ring on the lower end of the combustion tube, as shown in Figure 3-16:



Figure 3-16 Sealing ring at the bottom

Note:

Quartz combustion pipe should be on the same axis as the burner head and the lifting cylinder and the cymbal.

Care should be taken when inserting the burner into the quartz combustion tube to prevent the expansion and expansion of the combustion tube.

Apply a layer of vacuum grease on the elliptical seal sleeve at the lower end of the burner tube to improve the sealing effect and facilitate installation.

3.2.5 Installation of reagents

Step 1 Fill one end of the cleaned and dried glass reagent tube with quartz wool. Load the appropriate reagents as required by the gas path. Then plug it with quartz wool at the other end of the reagent tube. The quartz wool and reagents at both ends must be filled tightly, otherwise the gas flow will be affected.

Step 2 Apply a little vacuum grease to the reagent tube interface, as shown in Figure 3-17:



Figure 3-17 Applying vacuum silicone grease

Step 3 Load the three test tubes into the corresponding positions, as shown in Figure 3-18:



Figure 3-18 Reagent installation

3.2.6 Signal pool installation

Step 1 First connect the small socket at the top corner of the sulfur amplification board of the signal pool, as shown in Figure 3-19:



Figure 3-19 Small interface

Step 2 Find a separate large socket and connect it, as shown in Figure 3-20:



Figure 3-20 Large socket

Step 3 Connect two signal lines of different lengths according to the distance difference, as shown in Figure 3-21:

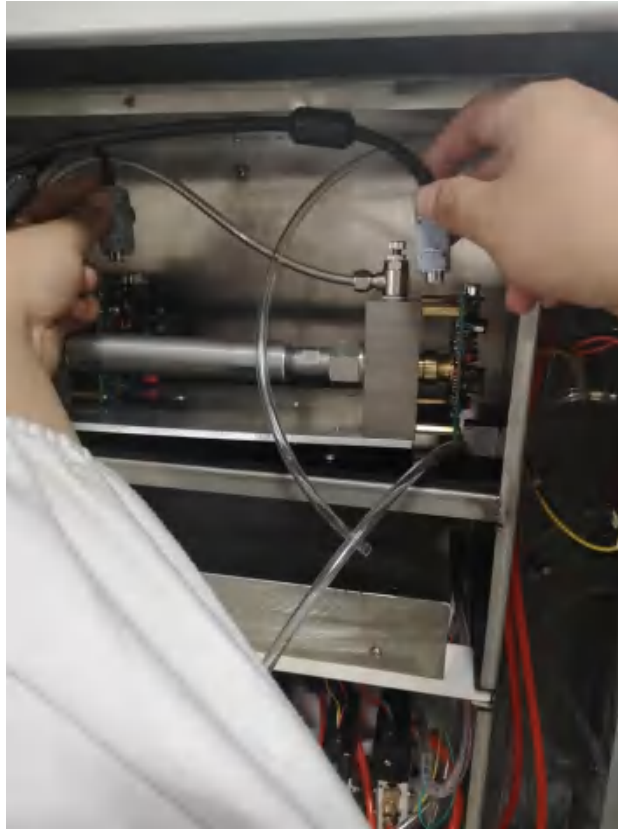

Figure 3-21 Signal Line

Step 4 Connect some of the inlet pipes on the instrument to the outside of the signal cell, as shown in Figure 3-22:

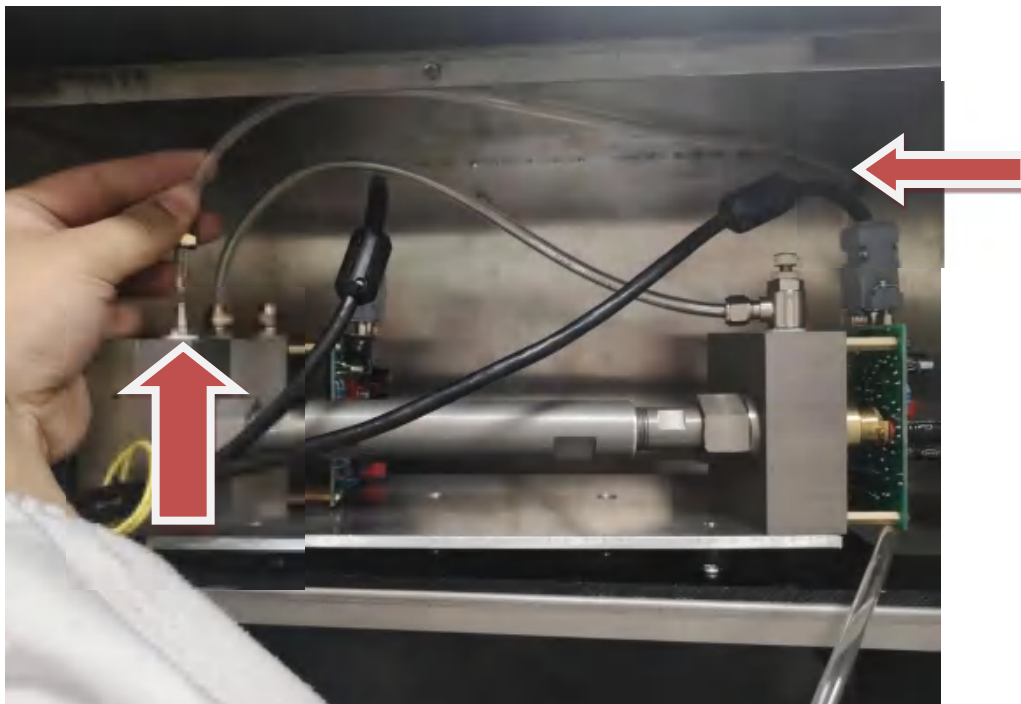

Figure 3-22 Intake pipe

Step 5 Connect the outlet pipe of the lower part of the instrument to the internal measurement of the signal cell, as shown in Figure 3-23:

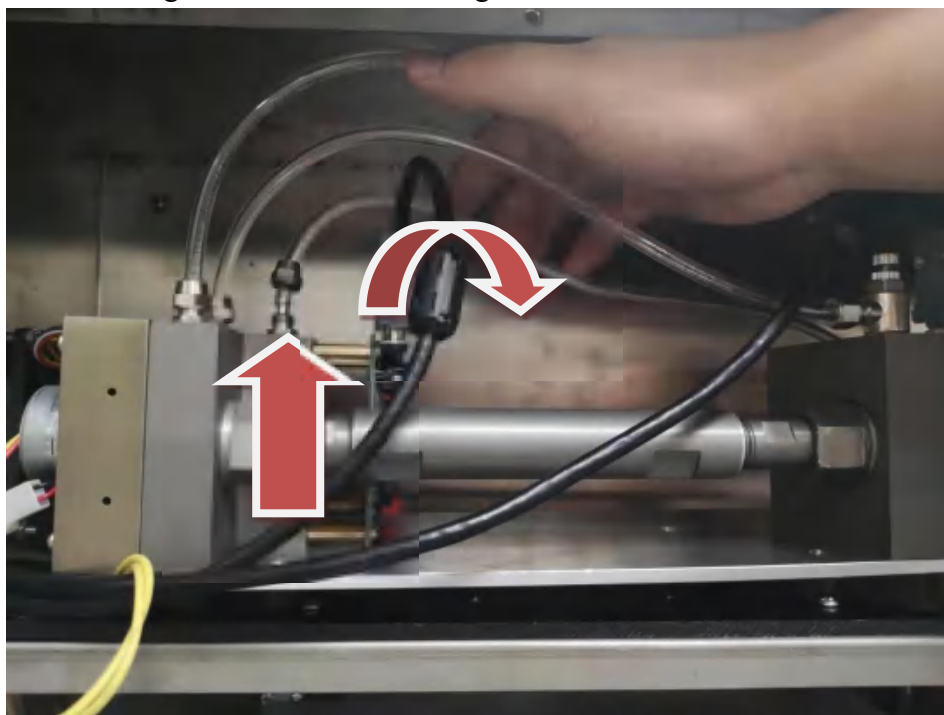

Figure 3-23 outlet pipe

3.2.7 Installation of gas path

Step 1 Connect the total oxygen of the instrument host to oxygen, and jump the oxygen flow to about 0.2Mpa, as shown in Figure 3-24:

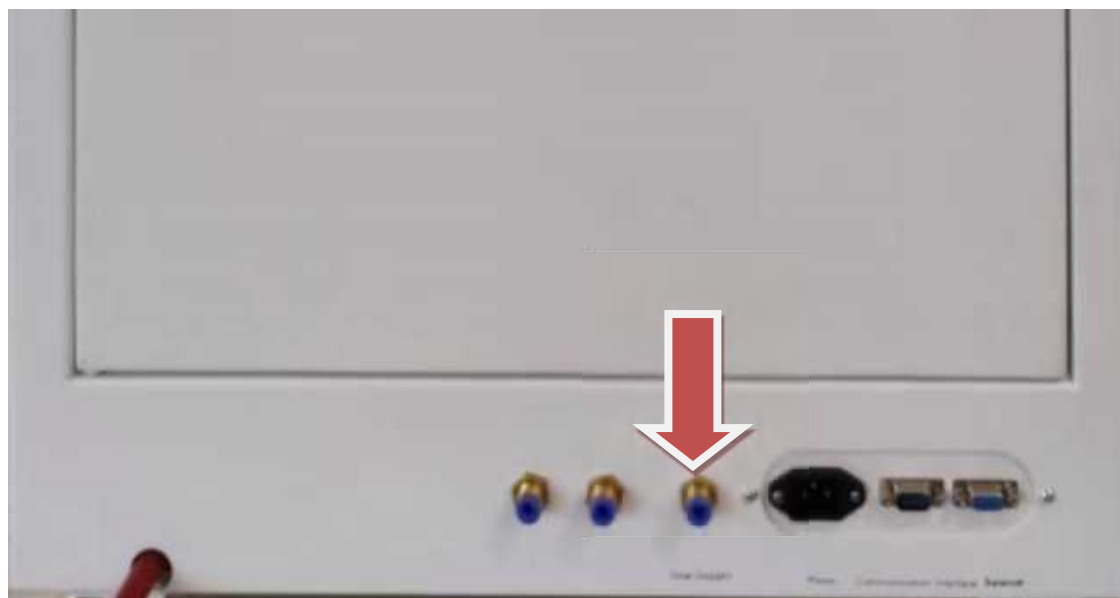

Figure 3-24 Instrument total oxygen interface

Step 2 Connect the instrument power cord and power it on. Now that all the connections to the instrument are ready, you can start working.

Chapter 4 System Installation and Analysis Software Features

4.1 Software Introduction

The software is based on the windows operating platform and is suitable for Windows XP, Windows 7, Windows 10 and so on.

4.2 Analysis Software Installation

The software in the U disk, to click the software setup installation program, following the installation prompts, you can install the CS analyzer Carbon & Sulfur Analyzer analysis software on the computer D disk. At the same time, according to the selection at the time of installation, the analysis program shortcut icon will be automatically generated on the desktop and the quick launch bar.

4.3 System Build Mode

The computer system of CS analyzer Carbon & Sulfur Analyzer adopts upper and lower computer technology, the PC interface uses RS232 data exchange technology, it constructs the working mode of the upper and lower machine communication system, single-chip microprocessor responsible for data acquisition and status control, it constitutes the lower position machine, and the upper computer performs data processing management, input and man-machine dialogue, the upper computer uses a famous brand of commercial computer, and the analysis software uses the windows series operating system.

4.4 Analysis Software Main Interface

The analysis software of CS analyzer Carbon & Sulfur Analyzer adopts the standard windows interface style, and combines the various needs of users, designed efficient and flexible analysis functions, fully embodies the purpose of humanized design. The main interface is shown below:

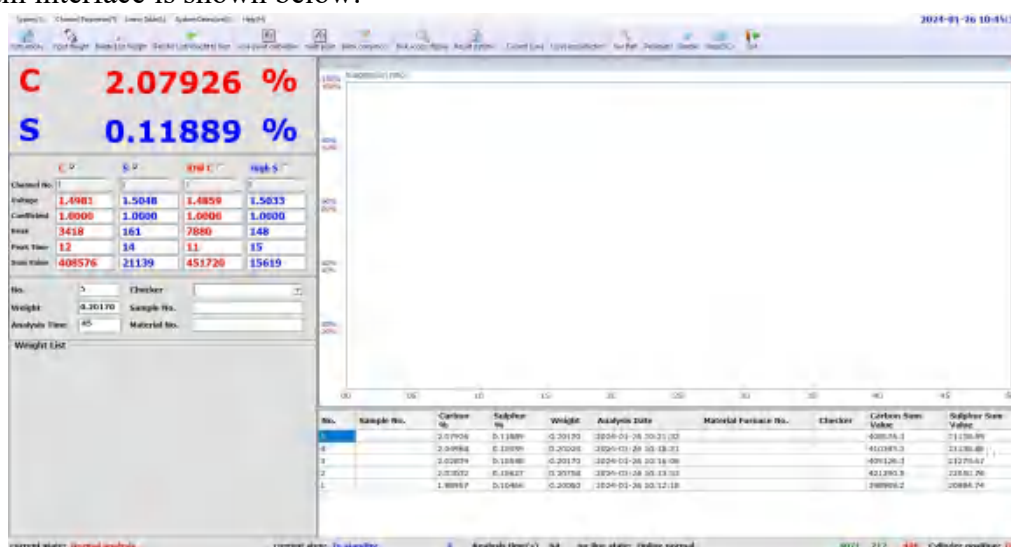

Fig.1

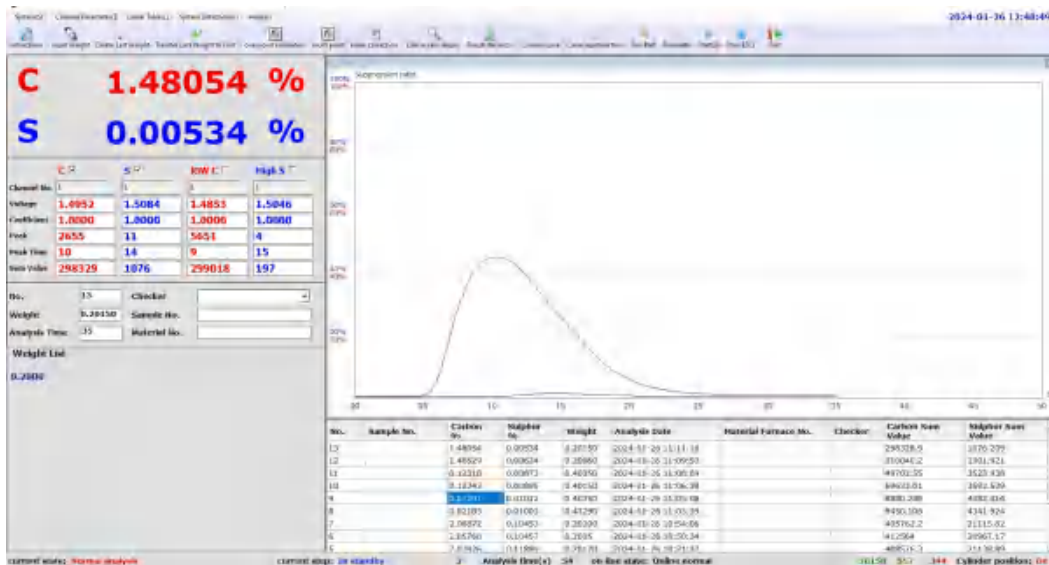

Fig. 2

The main screen is divided into three areas: upper, middle and lower. The area on the screen is the prompt line. The middle is the carbon and sulfur data frame and the corresponding status prompts in the analysis process.

There are seven items in the carbon and sulfur data frames in the middle of the screen. The contents are as follows: there are two lines of large characters above the data frame, the upper is carbon, and the down is sulfur. When the instrument is in the analysis state, the instantaneous values of the relative concentrations are displayed here. After the analysis, the mass fraction of carbon and sulfur in the sample for analysis is displayed. The remaining six items show that carbon and sulfur are consistent. Let us take the example of carbon to explain.

- “Channel Number”: It shows the channel number used in this analysis;
- “Pool Voltage” : It shows the real-time voltage value of the carbon analysis pool;
- “Coefficient Calibration”: It represents the correction value used to analyze the sample currently;
- “Peak Value”: It is shown as the value of the peak;
- “Peak Value Time”: It refers to the time it takes to analyze to the peak;
- “Cumulative value”: It refers to the sum of the instantaneous concentrations of this analysis.

The above shows that except for the “Pool Voltage” has been changed, the rest of the data is maintained until the beginning of the next analysis (including the current weight in the weight data). Each time the analysis is started, the “Channel Number” and “Coefficient Calibration” are unchanged, and the other three items are cleared. They will have corresponding data at the end of the peak and at the end of the analysis.

4.4.1 Color Display Rule

In order to facilitate the observation of the screen and convenient operation, the instrument makes some reasonable arrangements for the screen display rules in the

software preparation. For example, both carbon and sulfur have obvious color differences in the display of data or curves. Carbon is in the red group and sulfur is in the blue color.

4.4.2 Alarm Display

After continuously analyzing 25 samples, the instrument will pop up a small window with red letters on the bottom right of the screen to remind the operator that the prompt is to clean the dust once.

4.5 Weight Operation

The weight is one of the important parameters involved in the results calculation, there must be weight in the weight library before analysis, otherwise it will not enter the analysis process. There are two ways to get the weight into the weight library. One is to manually enter the weight, using the balance to weigh the sample weight or burn the waste sample and take any weight data, type it through the keyboard. The specific operation is pressing the “F4” button or clicking the “Input weight” button with the mouse, or clicking “ Current Weight” , the weight input window pops up behind “Current Weight” and the cursor flashes, then enter the weight through the keyboard, press the “Enter” button. The other is to automatically search for the weight of the computer, it can use the electronic balance connected with the instrument. Put the processed porcelain crucible into an electronic balance, after the display is stable, press the “TAR” button to remove the tare weight, and then add the sample to the porcelain crucible to the required weight, after stabilization, press the “PRT” button and the balance will send the weight data. After the computer receives the signal from the balance, it automatically searches for the weight and stores it in the weight library in order, and displays it in the weight library data box on the screen.

Note: When the operator manually type the weight or the computer automatically searches for the weight, the weight range is specified between 0.0001 and 200.000g, otherwise it is invalid.

In the special case, the following two treatment methods can be adopted.

- 1. Click the “Clear End Weight” button on the screen to clear the weight of the last number in the weight library.**
- 2. Click “Turn End Weight to First Weight” on the screen to move the weight of the last number in the weight library to the first position, and the other weight data will be shifted back by one.**

4.6 Analysis Operation and Display

4.6.1 Conditions and Operations Required to Enter the Analysis State

The instrument needs to have two conditions and one operation when entering the analysis state. Two conditions are: One is that there must be weight in the weight library. The second is that the combustion furnace cylinder must complete a furnace to

the furnace process, one operation is after having the above conditions, the operator needs to click the “Start” button or the “Automatic Analysis” button at the top right of the screen to enter the analysis state.

Note: If you click the “Automatic Analysis” button, the instrument will enter the automatic analysis state. For each sample analyzed, simply operate the balance to enter the weight and operate the high frequency oven. The instrument can be analyzed automatically without clicking the “Start” button with the mouse.

4.6.2 Analysis Process Display

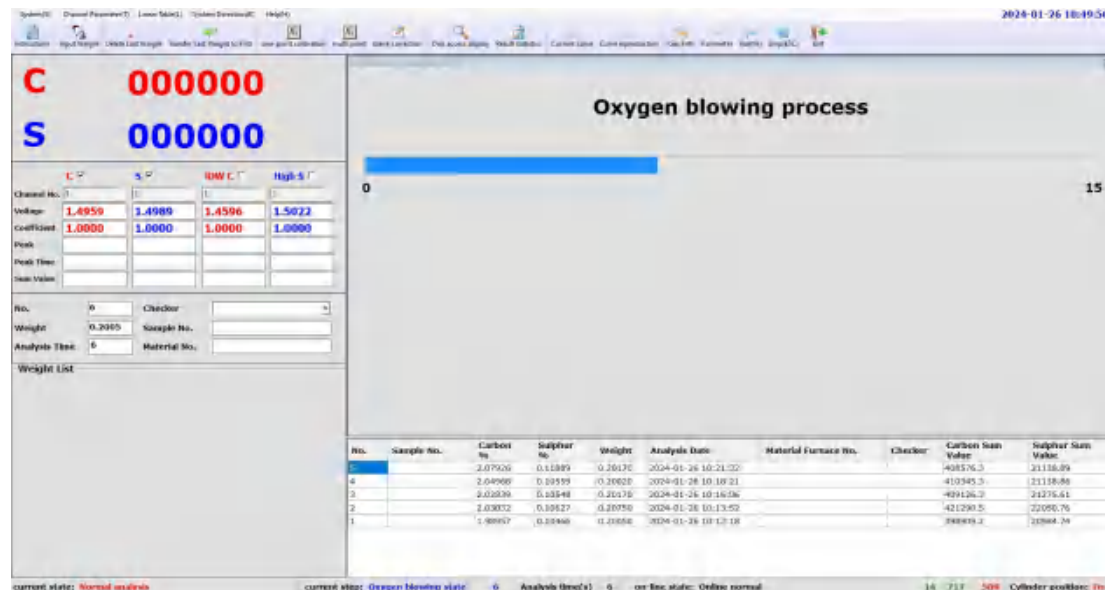

Fig.3

4.6.3 Interrupt Analysis or Pause Analysis

The “Esc” button has a general function of returning to the screen, and there are 2 other functions. During the first half of the analysis, press the “ESC” button to pause the oxygen blowing. At the same time, the screen will prompt you can pause the oxygen in the purple word and press “Start” button to start again. When the analysis enters the analysis state, press the “Esc” key to force the interruption analysis, it means that the analysis is terminated ahead of time. At this time, the computer will process and display various data as the automatic analysis ends, and then exit the analysis process. This type of operation is generally only used when the instrument fails.

4.6.4 Storage, Printing and Saving after the End of the Analysis

Process

A result database is provided in the instrument memory, and after each analysis, the instrument automatically stores the analysis result data in the library. The data in the

result library can be read, counted, printed, etc. at any time. See section 5 of this chapter for details. After each analysis, the instrument automatically saves the analysis result data into the database, and also automatically saves each measurement result to the hard disk for later reference.

4.6.5 Real-time Curve Display and Storage

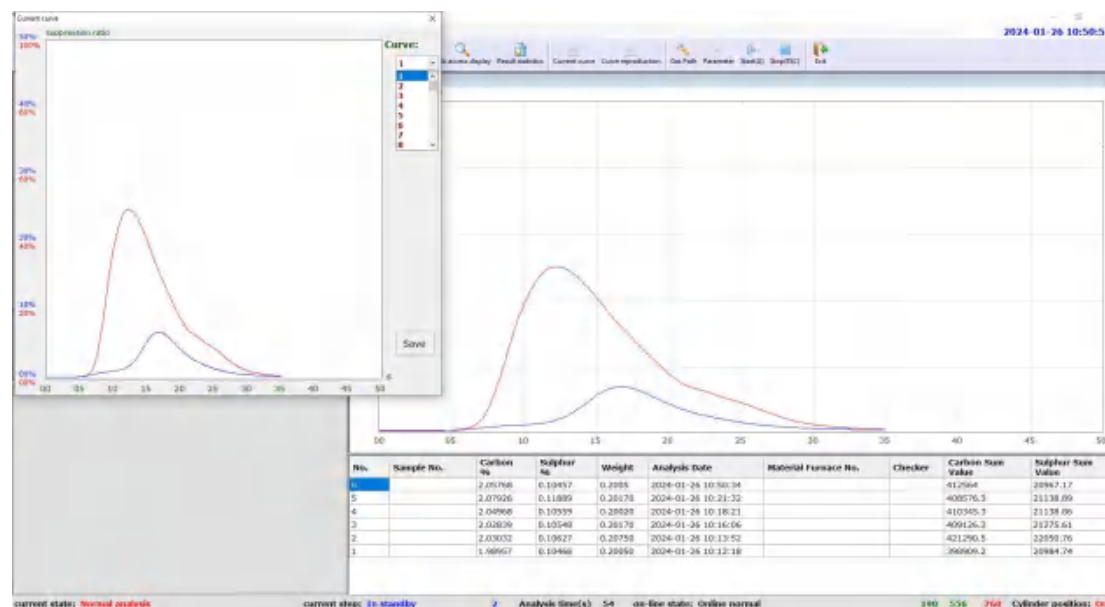

Fig.4

This instrument has 50 curve libraries, the curve library number is 1 to 50, after each sample is analyzed, if you want to save the current curve, then use the mouse to click the third line “Current Curve”, and the screen will display the current curve. Use the mouse to select the curve number, then click “Save Curve”, as the picture shows Fig.4

4.7 Analysis Software Function

The instrument has 9 functions, the function represented by F1~F9 on the keyboard is:

F2	F3	F4
One-poin calibration	Gas Path	Input Weight
F6	F7	
Disk access display	Results statistics	

The above function key can also be realized by directly clicking the second and third line function buttons on the screen area with the mouse. In addition, there are functions such as “Start” and “Stop”. In any function state, press “Esc” to exit. The contents are described separately below (The weight input operation is omitted. See section 3 of this chapter for details.)

4.7.1 Channel Selection and Channel Parameter Modification

No.	Para0	Para1	Para2	Para3	Short Time	Blow Oxygen	Up to Level	Blank Value	Channel name	Multipoint curve	Initialization
1	0.0000	1.0000	0.0000	0.0000	35	15	5	0.000000			
2	0.0000	1.0000	0.0000	0.0000	35	15	5	0.000000			
3	0.0000	1.0000	0.0000	0.0000	35	15	5	0.000000			
4	0.0000	1.0000	0.0000	0.0000	35	15	5	0.000000			
5	0.0000	1.0000	0.0000	0.0000	35	15	5	0.000000			
6	0.0000	1.0000	0.0000	0.0000	35	15	5	0.000000			
7	0.0000	1.0000	0.0000	0.0000	35	15	5	0.000000			
8	0.0000	1.0000	0.0000	0.0000	35	15	5	0.000000			
9	0.0000	1.0000	0.0000	0.0000	35	15	5	0.000000			
10	0.0000	1.0000	0.0000	0.0000	35	15	5	0.000000			

Fig. 5

Please click on the screen “Channel Parameter”, the user selects the channel that needs to be changed. (See Fig. 5)

When the carbon channel parameters need to be modified, please click the "Channel Parameters" button. After the channel parameter list pops up on the screen, press any key and click the “Modify” button in the lower left corner of the parameter list with the mouse. It will automatically pop up the “Please enter a operation password” prompt, enter the password and press “Enter” (password: 12345), if the data in the channel corresponding to “INIT” is selected in the corresponding channel, it returns to the original data. If there is data in the corresponding channel, the operator can view the linear curve of these data in this channel. If the sulfur channel needs to be modified, it is consistent, with the carbon channel method.

4.7.2 Results

Please press “F7” or click “Results” button, the screen displays the calendar of the current month. After selecting the date with the mouse, click the “Confirm” button. The screen displays the data list of the analysis result of the day, and selects it with the mouse in the selected column, if there is “√” in the space, it is the data participating in the statistics, otherwise it will not participate in the statistics. After the selection is complete, click the “Analysis Statistics” button in the lower left corner of the statistics table. The screen displays the statistics result list. If you want to print it, click “Print” button. (See Fig. 6). Please press “ESC” or “Cancel” to return to the main screen.

Year	Year+Month	Year+Month+Day	Analysis Date	No.	Carbon %	carbon coefficient	Sulphur %	Sulphur coefficient	Weight	Checker	Material Furnace No.
2024	2024-01	2024-01-26	2024-01-26 10:21:32	0005	2.07926		0.11889		0.20170		
2023	2023-12	2023-12-25	2024-01-26 10:18:21	0004	2.04968		0.10559		0.20020		
		2023-12-27	2024-01-26 10:16:06	0003	2.02839		0.10548		0.20170		
		2023-12-25	2024-01-26 10:13:52	0002	2.03032		0.10627		0.20750		
		2023-12-22	2024-01-26 10:12:18	0001	1.98957		0.10466		0.20050		
		2023-12-22									
		2023-12-14									
		2023-12-13									
		2023-12-12									
		2023-12-08									
		2023-12-07									

Fig.6

4.7.3 One-point Calibration

No.	Analysis Date	Carbon %	Corrected value	Sulphur %	Corrected value	Weight
7	2024-01-26 10:54:06	2.00872		0.10453		0.20200
6	2024-01-26 10:50:34	2.05768		0.10457		0.2005
5	2024-01-26 10:21:32	2.07926		0.11889		0.20170
4	2024-01-26 10:18:21	2.04968		0.10559		0.20020
3	2024-01-26 10:16:06	2.02839		0.10548		0.20170
2	2024-01-26 10:13:52	2.03032		0.10627		0.20750
1	2024-01-26 10:12:18	1.98957		0.10466		0.20050

Carbon standard value: C-Para 1.0000

Sulfur standard value: S-Para 1.0000

Revise Save Exit

Fig. 7

Please press “F2” or click “One-point Calibration” button, the screen pops up “Carbon and Sulfur Calibration”, and then press “Enter” or click “ Ok”, the screen pop-up analysis data table for correction factor, at this point, use the mouse to make a “click” on the carbon and sulfur data that needs to be calibrated in the calibration column space (see Fig. 8), click again to delete the selection. After selecting, click the “Calibration” button, immediately pop up on the screen, please enter the carbon and sulfur standard content prompt window, after inputting the carbon and sulfur content data through the keyboard and pressing “Enter” or clicking the “Confirm” button, the carbon and sulfur coefficients are calibrated, the coefficient calibration value is automatically stored in the selected channel of the channel library, and the analysis

results will be transferred from the above modified value participate in the operation.

4.7.4 Multi-point Calibration

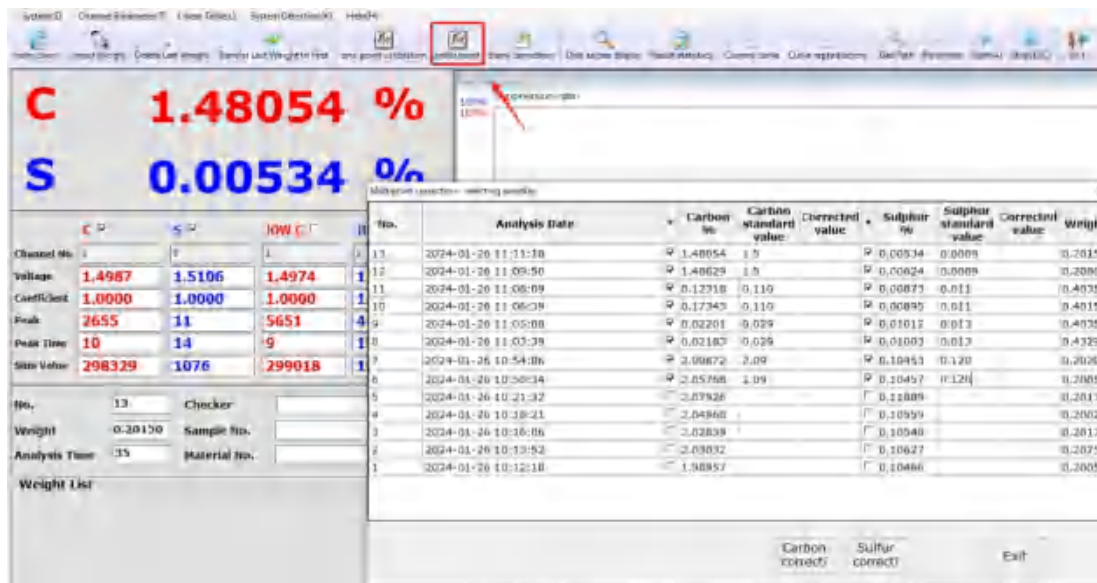

Fig. 8

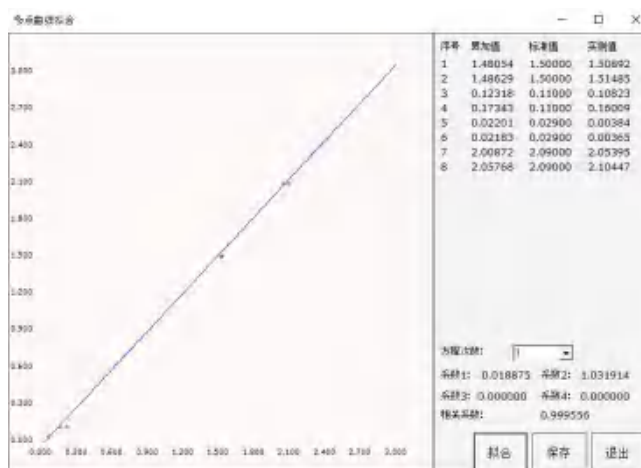

Fig. 9

Click "Multi-point calibration" in the main menu, at this point, using the mouse to make "√" on the carbon and sulfur data that needs to be calibrated in the calibration column space, and then entering the corresponding carbon and sulfur standard content on the sulfur value column (see Fig.8). After selecting, click the "Calibration" button with your mouse, the multi-point calibration curve pops up on the screen (see Fig.9). The cumulative value of the abscissa and the ordinate are the carbon content and the sulfur content, adjusting the number of equations in the "Number of Equations" window to make the calibration value close to the carbon value and the sulfur value. After clicking the "confirm" button, the carbon and sulfur multi-point coefficients are calibrated. The multi-point calibration coefficient value is automatically stored in the channel selected by the channel library, and the analysis result will be transferred from the above modified value to participate in the operation.

4.7.5 Current Curve Display

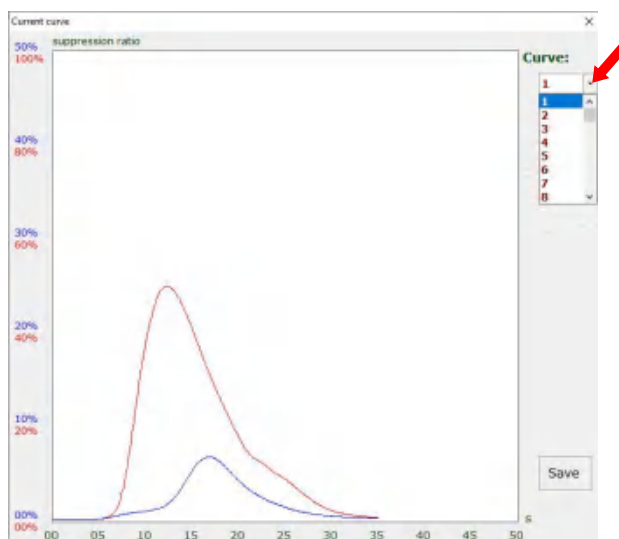

Fig.10

Please click “Current curve” button, a black frame pops up on the screen, click “▼” under “Curve” on the right side of the black frame. After selecting the curve number, the operator can reproduce the curve he or she needs, if you need to print, please click on “Print” below (See Fig. 10)

4.7.6 Curve Reproduction

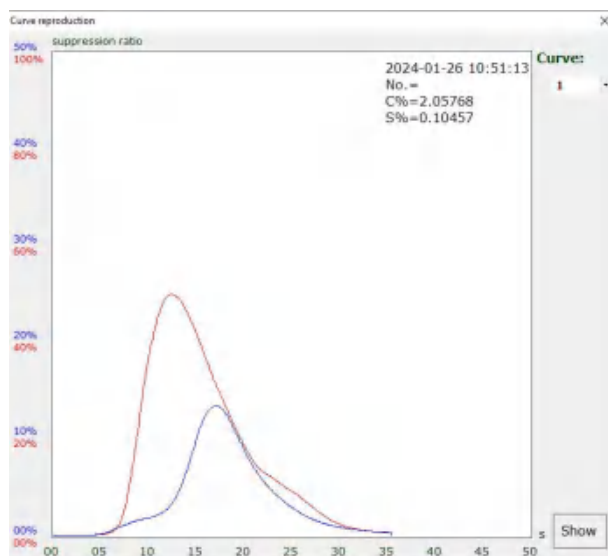
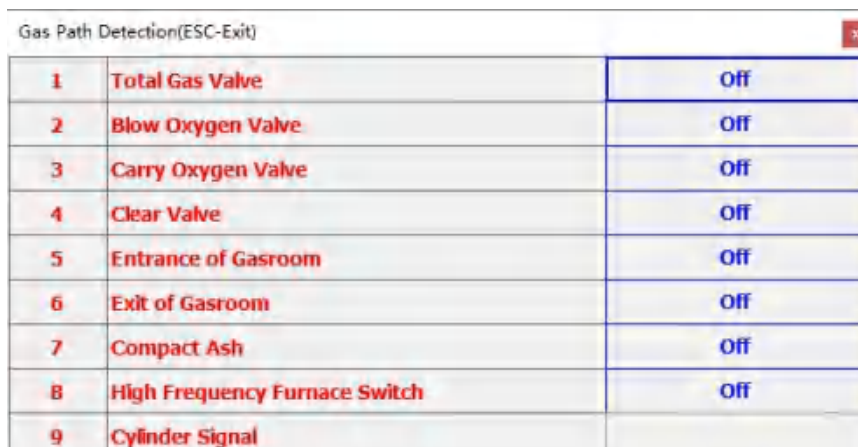

Fig.11

Please click “Curve Reproduction” button, a black frame pops up on the screen, click “▼” under “Curve” on the right side of the black frame. Then click on the curve number of the curve, and then display the corresponding curve in the black box. And then click a curve number to display a curve and corresponding parameters, so that the operator can compare. Sulfur curve comparison operation is the same as carbon. (See Fig. 12)

4.7.7 Gas Path



Serial Number	Component Name	Status
1	Total Gas Valve	Off
2	Blow Oxygen Valve	Off
3	Carry Oxygen Valve	Off
4	Clear Valve	Off
5	Entrance of Gasroom	Off
6	Exit of Gasroom	Off
7	Compact Ash	Off
8	High Frequency Furnace Switch	Off
9	Cylinder Signal	

Fig.12

Please press “F3” or click “Gas Pas” button, a gas path detection table pops up on the screen, click on the On/Off behind any serial number of “1-8”, the solenoid valve or high frequency furnace corresponding to the number can be turned on or off, press once to open, press again to close. This operation is used to check the air circuit seal and repair the instrument.

Note: Turn the above switch on or off, provided that there is a cylinder signal, otherwise it is invalid. (Fig. 12)

4.7.8 Blank Calibration

Please click “Blank Correction” button, the screen pops up a blank calibration table, the sample analysis results are listed in the table. After selecting the carbon and sulfur data with the mouse, click the “Revise” button, after that, the blank value in the current channel line in the channel parameter table is changed to the calibration value.



No.	Analysis Date	* Carbon %	ctd	* Std	Sulphur %	Weight
-----	---------------	------------	-----	-------	-----------	--------

Revise Save Exit

Fig.13

4.7.9 Result Query and Print

Result statistics (the number of statistical samples cannot be less than 2)

No.	Analysis Date	+	Carbon %	+	Sulphur %	Weight	Checker	Material Furnace No.	Sample No.
11	2024-01-11 09:57:39	Γ	92.13079	Γ	0.15550	0.01530			
10	2024-01-11 09:52:05	Γ	99.80450	Γ	0.18550	0.00950			
9	2024-01-11 09:48:27	Γ	99.63974	Γ	0.15026	0.01330			
8	2024-01-11 09:46:28	Γ	99.81548	Γ	0.17452	0.01210			
7	2024-01-11 09:43:35	Γ	2.48370	Γ	0.07838	0.20100			
6	2024-01-11 09:40:01	Γ	2.47295	Γ	0.07866	0.20490			
5	2024-01-11 09:37:52	Γ	2.48992	Γ	0.07564	0.21360			
4	2024-01-11 09:33:03	Γ	0.43964	Γ	0.03563	0.4086			
3	2024-01-11 09:31:00	Γ	0.43942	Γ	0.03476	0.39920			
2	2024-01-11 09:24:45	Γ	0.43982	Γ	0.03471	0.3999			
1	2024-01-11 09:21:29	Γ	0.43494	Γ	0.03100	0.4004			

	C	S	Select time 2024-01-11
Average	0.000000	0.000000	
Standard deviation	0.000000	0.000000	
RSD(%):	0.000000	0.000000	

Stat Print Exit

Fig. 14

Please press “F6” or click “Disk access display” button, the result database data is displayed on the screen, and all the analysis data of the selected date can be queried after selecting the data as needed. If you need to print, double-click the left mouse button on the “No” word under the “Print” column in the displayed data table to select the print.(See. 14)

4.7.10 Analyze Data to be copied from the computer

Figure 14 to copy the data of the day of that year, as long as you can “transfer to Excel” on the day of that year, then find the “Excel” file in the directory of the installer, copy the data all over in the “Excel” file.

4.8 The Principle of Parameter Setting

The various combinations of analytical condition parameters of the instrument are the analysis channels. CS analyzer Carbon and Sulfur Analyzer software has 10 channels of carbon and sulfur, each group of channels contains a set of default initialization settings. The operator can decide the distribution according to different material types and different content ranges. The meanings and setting methods of each analysis parameter involved in the channel are described in detail below.

4.8.1 Pre-blowing Oxygen Time

Due to the dynamic equilibrium of gas adsorption and release from the tube wall, when analyzing high-content samples, the concentration of CO₂ and SO₂ is high, and the wall adsorption increases. When analyzing low-level samples or when taking pure oxygen to take the reference signal, the gas adsorbed on the inner wall of the pipeline is gradually released, which will inevitably affect the value of the analytical reference

signal or the accuracy of low-level analysis. Therefore, before the sample analysis, the system is cleaned with pure oxygen. The length of the cleaning time is the oxygen blowing time. According to the analysis accuracy and the analysis speed, the appropriate oxygen blowing time should be selected. Usually set to 15 seconds. For low content analysis, it can be set to 20-25 seconds.

4.8.2 Shortest Analysis Time

The shortest analysis time is the shortest time for sample heating after the end of the oxygen blowing time, for the analysis of ultra-low content samples, the analysis time must be controlled by setting the shortest analysis time due to the small peak value. For ultra-low content analysis, pre-analyze low-level samples and observe the release curve. If the tail of the release curve is too much, increase the minimum analysis time. Conversely, the tail of the release curve drags too long, reducing the minimum analysis time.

4.8.3 Longest Analysis Time

In order to prevent the abnormal tailing situation from occurring, the analysis result is seriously affected, and the program has the longest analysis time parameter. The value of this parameter indicates that the analysis program forcibly ends the analysis regardless of the situation and the analysis time of the setting.

4.8.4 The Working Time of High Frequency Furnace

The time refers to the high frequency furnace opening time after the end of oxygen blowing, which may be inconsistent with the shortest analysis time and the longest analysis time, and is generally set to be the same as or shorter than the complete release time of carbon(5 seconds).

4.8.5 Up to Level

The CO₂ and SO₂ infrared absorption curves are basically a normal distribution curve, and the analytical data is proportional to the integral value of the curve area.

Starting Level: The level at which the computer starts to integrate

Up to Level: The level at which the computer stops integrating

Peak Level: Curve lowest level

Initial Integral Value: Digital quantity corresponding to the starting level

Cut-off integral value: Digital quantity corresponding to the Up to level

Peak Value (P): Digital quantity corresponding to the peak level

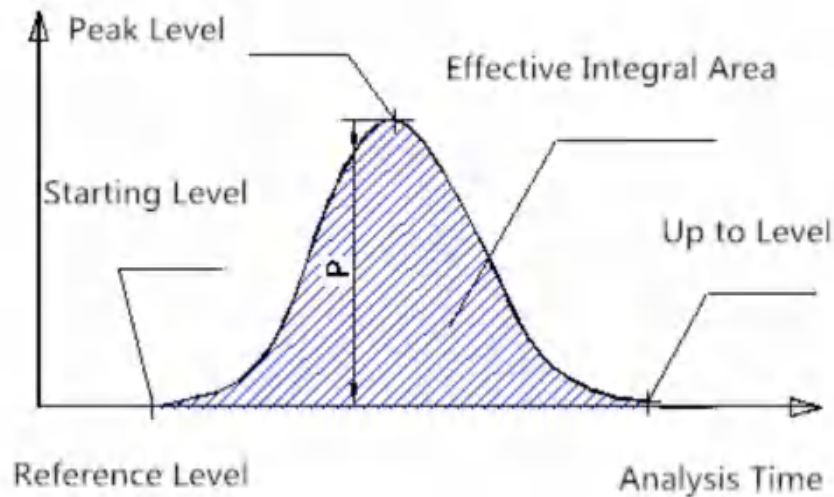

Up to Level: The analytical data is proportional to the area integral value of the release curve, so the accuracy of the area will also affect the correctness of the analytical data. Because the Up to level is set by the peak height value of the release curve of the analysis process. If the Up to Level is set to low, analysis time is prolonged, which increases the influence of the blank value in the system, which not only prolongs the analysis time of the sample, but also reduces the analysis accuracy.

If the Up to Level is set too high, the analysis time is shortened, and the sample combustion is incomplete, which will also affect the accuracy. Furthermore, due to the different materials and weights of the samples, the release process is different during the analysis, so it is impossible to end the analysis at a fixed time. The instrument provides an analysis condition setting function, and the user can set the cutoff level according to the sample characteristics, analysis accuracy and curve release.

The program provides 10 different Up to Levels for the user to select the appropriate Up to Level based on their respective analytical conditions and the carbon and sulfur release in the sample. The following table lists the relationship between the Up to Level and the peak value of the Up to Level:

Up to Level	10	9	8	7	6	5	4	3	2	1
X (%)	51.2	25.6	12.8	6.4	3.2	1.6	0.8	0.4	0.2	0.1

Generally, the carbon Up to Level value is set at about 5, and the sulfur Up to Level value is set at about 6, the following shows the case where the Up to Level is set too high or too low.

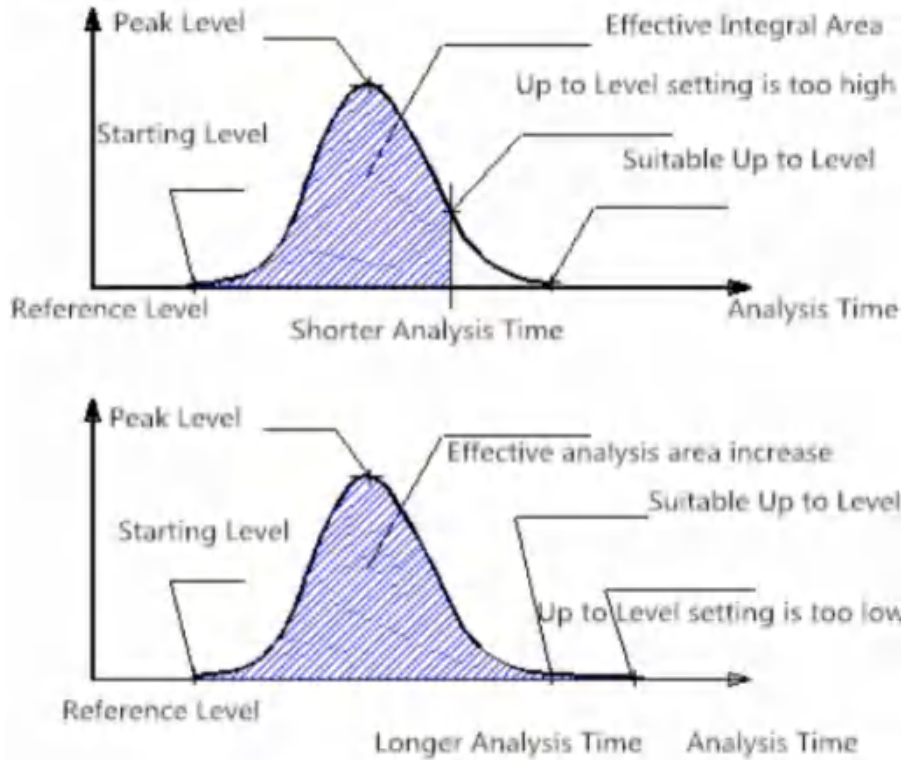

4.8.6 Coefficient Calibration

After linearization of the instrument, the infrared signal is linearly related to carbon and sulfur content over a wide range, However, due to changes in instrument state and environmental conditions, the analysis results will deviate from the true value. Since the deviation is a systematic error, the correction coefficient can be obtained by using the deviation value between the experimental value of the standard sample and the standard value according to the linear equation, so that the analysis results is calibrated. The standard value divided by the analysis result is the coefficient calibration, when the analysis result is equal to the standard value, the coefficient calibration is 1.

4.8.7 Blank

The instrument blank is basically 0, but the used porcelain crucible, oxygen and flux systems will introduce some blank values more or less, moreover, due to different materials, the processing method and instrument state will vary from 0.000x to 0.00x%, the impact on high carbon and sulfur samples is negligible, the impact on high carbon and sulfur samples is negligible.

4.8.8 Standard Value

When making coefficient calibration and blank value, it must be obtained by experiment with reliable standard sample. After calculating the coefficient calibration and blank, the standard value of the standard sample will be automatically saved for reference.

Chapter 5 Instrumental Analysis

Operation

5.1 Analytical Preparation

5.1.1 Porcelain Crucible

The main components of ceramic crucible are alumina and silica, and it is inevitable to introduce a small amount of C and S in the process of raw material processing and sintering, and these components are more apt to adsorb CO₂, water vapor and impurity gases containing C and S in the environment. If used directly, its carbon content ranges from 0.001% to 0.002%. In addition, the water vapor adsorbed in the crucible absorbs a certain amount of heat when it is burned, and then condenses in the cold gas pipeline, and then absorbs SO₂ to form sulfurous acid, so that the sulfur analysis result is low. If the water vapor enters the absorption tank with the analysis gas, it will be close to SO₂ due to its absorption wavelength, which makes the sulfur analysis result higher. Therefore, it is necessary to pre-treat the crucible.

- (1) Routine analysis of porcelain crucible treatment: the crucible is piled up in a muffle furnace, and is naturally cooled to a normal temperature by burning at a temperature of 1000--1200°C for 4 hours, and placed in a desiccator for use.**
- (2) After treatment, it is not suitable for long-term release, especially for low-carbon, low-sulfur samples. It is best to use warm temperature around 70°C**

5.1.2 Flux

Flux is essential in carbon and sulfur analysis, adding a certain amount of flux can reduce the melting point of the sample and make the sample easy to burn, on the other hand, in the combustion process, the flux also has an oxidative exothermic effect, which contributes to the improvement of the combustion temperature of the sample.

Tungsten grains and their alloys(such as W-Sn, W-Fe-Sn, etc.) are commonly used fluxing agents for high frequency furnaces. Tungsten grain itself has a high melting point(3380 °C), which can not reduce the melting point of the sample, but tungsten has a higher heating value, and the chemical activity increases rapidly at high temperature, which is easy to oxidize and burn. Tungsten particles have good gas permeability, no burning, and have effect of reducing the rate of carbon and sulfur release and stabilizing the results of carbon and sulfur analysis. After the tungsten is burned, acidic tungsten trioxide is formed, which has a good effect on eliminating sulfur adsorption. When the tungsten particles are used in a high frequency furnace, the particle size is preferably from 20 mesh to 40 mesh. Generally, the amount added is about 1.5g to 2.0g.

Tin particles can also be used in high-frequency furnaces. Tin has a low melting point(232 ° C) and has a good fluxing effect. It can increase the fluidity of the sample

during combustion and make the slag bright and smooth. However, the tin particles generate a large amount of SnO₂ dust during the combustion process, which seriously affects the stability of the sulfur determination, so the amount of addition should not be too much, usually about 0.15g to 0.2g.

Pure iron is also a good flux. It can reduce the alloy ratio of the sample, play a dilution role, and is easy to melt and burn. Generally, the amount added is about 0.3g to 0.5g.

5.1.3 Standard Material

Demand:

1. Primary or secondary reference materials approved by the National Bureau of Standards during the validity period.
2. The standard substance variety is the same as the sample being tested.
3. The calibration standard substance has a carbon sulfur content higher than the carbon sulfur content of the sample to be tested.

5.1.4 Sample Preparation

1. Sampling: The geometry shape of the sample has an influence on the analysis. Before analysis, the sample should be processed into fine grains or fragments suitable for analysis, so as to facilitate combustion and melting.(How to make different solid samples be treated effectively: 1. Ore samples, 2. Metal samples, 3. Soil samples, 4.Coal samples), The non-uniformity of the sample will cause irregular fluctuation of the analysis results, and produce a large discreteness of individual data. This moment, refining the sample (0.104mm) can effectively improve the test, or the results are obtained by statistical methods.

2. Cleaning: The sample may be contaminated. Clean the sample's surface before analysis.For ultra-low carbon and sulfur analysis,Clean with acetone, diethyl ether, alcohol and other reagents, clean with pure water and dry with hot air. For powder samples are not easy to be cleaned with reagent. Powder samples can be baked by infrared lamp, to remove moisture and adsorbed gases.

3. Dry: The powder sample was easy to absorb water and was pretreated in an oven at 110 ° C for 2 h before analysis.

5.1.5 Reagent

High-efficiency discoloration desiccant, the main component is magnesium perchlorate.

Highly efficient CO₂ absorbent, the main component is alkali asbestos.

Quartz cotton

5.1.6 Power Supply

220V 50Hz. It requires 5KW AC parameter regulator

5.1.7 Oxygen Supply

Analyze the gas source, Oxygen purity>99.5%, Oxygen bottle pressure>3.0MPa Input pressure 0.18Mpa ~0.20Mpa

Note: If it is used for low-carbon and low-sulfur determination, it requires high purity oxygen (purity >99.99%)

5.2 Boot Step

5.2.1 Power Ups

1. First turn on the computer, turn on the infrared carbon sulfur meter power switch before hitting the "infrared carbon sulfur meter" icon on the computer screen.
2. Turn on the infrared carbon sulfur meter power switch, the infrared host computer and the computer enter the automatic online state, and the connection is stable for 30 minutes after the normal connection.
3. Turn on the high frequency furnace power switch and preheat the high frequency tube filament for 10 minutes.

5.2.2 Oxygen

Open the oxygen cylinder and adjust the pressure reducing valve to 0.18Mpa~0.20Mpa

5.2.3 Inspection Reagent

The high-efficiency discoloration desiccant changes from yellow to red after failure, and the failed part should be replaced in time. After the failure of the high-efficiency CO₂ absorbent, it will change from pale purple to rose red, and the failed part should be replaced in time. Quartz cotton turns yellow after ashing, and should be replaced in time for failure.

5.2.4 Cleaning Dust

Cleaning the quartz combustion tube and the dust inside the metal filter

5.2.5 Check the Working Status of the Instrument

Open the oxygen cylinder and adjust the pressure reducing valve to (0.2Mpa), Open the lift switch on the high frequency furnace (cylinder up), open the "Gas Path Test" in the middle of the third row on the upper left side of the infrared interface. First look at whether the "yes" of the cylinder signal is red, it is red indicating that the connection is normal, and the black is that the connection is not normal. The operator should check whether the limit switch in the high frequency furnace and the spring piece of the switch are in good contact, "Yes" displays the red and then opens the solenoid valve (computer keyboard) "1, 2, 3, 5, 6" to adjust the "oxygen pressure" table on the high-frequency oven panel to 0.08Mpa. "Top Oxygen Flow" adjust to (1-1.5) liters (generally adjusted to 1.2), "Analyze Gas Flow" is (3.0-4.0, please adjust gas flow at the air chamber). On the contrary, close the solenoid valve(computer

keyboard) “6, 5, 3, 2, 1,” see if the pointer on the “Carry Oxygen Pressure” table changes within 1 minute, no change indicates that the gas path does not leak. If there is a change: the airway leaks, please check if the quartz tube on the high frequency furnace is broken. 2. Whether the red ash pipe is broken. 3. Please check if there is too much gray on the burner of the porcelain crucible or the silicone ring is cracked. 4. Whether the joint of the cleaning pipe joint is sealed. Under the premise that the above conditions are normal, open the high frequency furnace switch on the “Gas Path”(computer keyboard 8), the " Anode Current Meter" table on the high frequency oven panel indicates that it is at (0.15-0.4) A, the " Grid Current " table indicates at (80-150) mA.

5.2.6 Analysis Condition Setting

1. Pre-oxygen blowing time setting

Why do operators need to blow oxygen to the system before each sample analysis?(also known as pure oxygen cleaning), this is because the gas adsorption and release of the gas pipe wall is in a dynamic equilibrium state. When analyzing high-content samples, the concentration of CO₂ and SO₂ is high, and the wall adsorption increases. When analyzing low-level samples or when taking pure oxygen to take the reference signal, the gas adsorbed on the inner wall of the pipeline is gradually released, which will inevitably affect the accuracy of the analysis reference signal and the low-content analysis. Therefore, the system should be cleaned by pure oxygen before each sample analysis, and the length of the cleaning time is the oxygen blowing time. We generally set the oxygen blowing time to 15s, and the ultra low or ultra high content analysis can be set to 20s~25s.

2. Minimum analysis time setting

Setting of the shortest analysis time for ultra low content samples:

The end time of the ultra-low sample release curve is determined by the shortest analysis time. Generally, a low-level sample can be pre-analyzed, and a reasonable minimum analysis time can be set according to the release curve, and the curve release complete time is set to the shortest analysis time.

Setting of the shortest analysis time for medium and high content samples. The shortest analysis time for medium and high content samples is generally set to 20 seconds and should not be too long.

3. Up to Level Setting

The Up to Level is set by the peak height value of the release curve of the analysis process. If the cutoff level is set too low, the analysis time will be prolonged, and the influence of the blank value in the system will be increased. If the cutoff level is set too high, the analysis time will be shortened, resulting in incomplete combustion of the sample, which will also affect the accuracy. Normal carbon Up to Level is set to 4 and sulfur Up to Level is set to 7.

4. Longest analysis time setting

In order to prevent the abnormal tailing situation from occurring, the analysis result is seriously affected, and the program has the longest analysis time parameter. The parameter value indicates that the analysis program forcibly ends the analysis

regardless of the situation. Generally, the longest analysis time of carbon is set to 35 seconds, and the longest analysis time of sulfur is set to 40 seconds.

5. High frequency conditions setting

Different types of materials, the release process of elements during combustion is different, and the same combustion power cannot meet the analysis of all materials. The same material also needs different combustion power in different stages of the analysis of the combustion process. The combustion power is changed by setting the high-frequency conditions, so that the carbon and sulfur elements in the sample are fully released to reach the optimum melting temperature.

5.3 Analysis Process

5.3.1 Sample Weighing

1. Net weight: Take a processed sputum on the electronic balance, and the electronic balance will be automatically peeled. The display is 0.0000, and after the circle appears on the lower left, it indicates that the balance has been peeled.
2. Sample weighing: Place the sample in the crucible and display a circle at the bottom left of the display to indicate that the balance is stable.
3. Enter weight: press [Enter]
4. Weight library: display weighing

5.3.2 Porcelain Crucible

1. Please press the lift switch, porcelain crucible supporting starts to fall
2. Use a pair of tweezers to place a porcelain crucible with sample on the quartz squat (stable and flat).
3. Please press the lift switch, porcelain crucible supporting starts to rise.

5.3.3 Start Analysis

Press the analysis button to enter the analysis program. After the analysis is completed, the display shows the results of carbon and sulfur analysis.

5.3.4 Cleaning the Burner

Please press the lift switch, porcelain crucible supporting starts to fall, and then use a pair of tweezers to take porcelain crucible out.

If necessary, press and hold the ash switch, and the cleaning brush will drop to clean the quartz tube.

Loosen the ash switch and sweep the cleaning brush will be back to the cylinder.

Please press the lift switch, porcelain crucible supporting rises and resets.

Once the operation is completed, the above operations can be repeated to analyze the samples in sequence.

5.4 Analysis Routine

5.4.1 How to Analyze a Sample

1. Taring

Please use a pair of tweezers to take a treated porcelain crucible, and then put the porcelain crucible on the balance (Centered placement), according to the peeling button of the balance, the balance automatically removes the weight of the crucible, and the analysis software balance display 0.0000, as shown in Figure 5-1:



Figure 5-1 Taring

2. Weight storage

Use the sample spoon to take a small amount of the sample to be tested and place it in the crucible. The amount of the sample added is in the analysis software 'balance weighing display window' display (general steel sample weighing about 0.5 grams, iron sample weighing about 0.2 grams), according to the balance of the "print button", as shown in Figure 5-2:



Figure 5-2 Input weight

3. Weight display

The weight is automatically entered into the computer and displayed in the weight library window. If the weight is not displayed, you can also manually enter the weight in the weight library window and click “Enter”, as shown in Figure 5-3:

No.	13	Checker	
Weight	0.20150	Sample No.	
Analysis Time	35	Material No.	
Weight List			
0.2000			

Figure 5-3 Weight display

4. Adding flux

Use a spoon to draw a small amount of tungsten flux about 1.5g- 2.0g evenly over the sample just weighted. (**Note: do 0.2000g of rare earth metal, add 0.3g of pure iron accelerator, plus 1.5g of tungsten. After making a pure iron sample, weigh 0.5g of pure iron, add 1.5g of tungsten**), as shown in Figure 5-4:



Figure 5-4 Adding tungsten particles

Note: The flux weight does not have to be input. For steel samples and most metal samples, only tungsten flux should be added. It cannot be replaced by other fluxes such as tin. Tin, pure iron, and tungsten fluxes are required for raw material analysis.

5. Porcelain crucible reset

Please press the lift switch on the high frequency furnace, make porcelain crucible supporting fall, and use a pair of tweezers to take a porcelain crucible with flux to put the porcelain crucible supporting, (Note: it must be placed in the middle, not eccentric and inclined, otherwise it will destroy the quartz tube), and at last, please press the lift switch, make porcelain crucible supporting goes up, as shown in Figure 5-5:

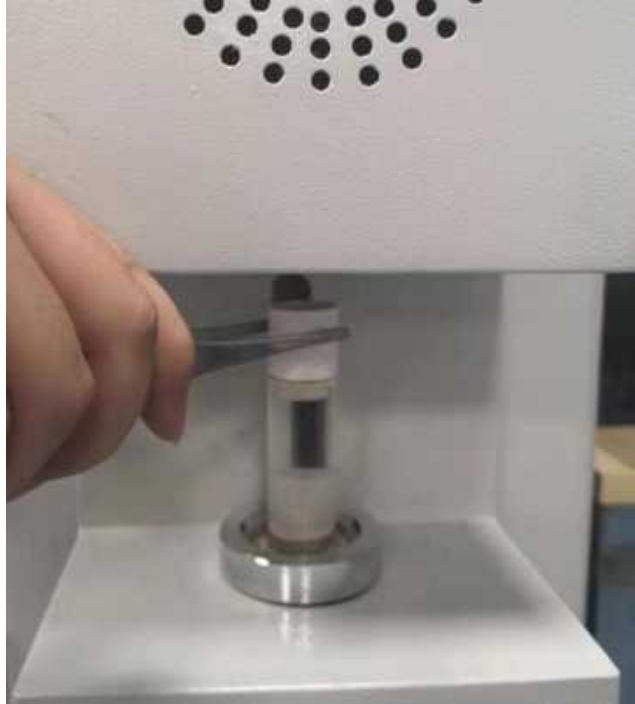

Figure 5-5 Place crucible

6. Automatic analysis

Use the mouse to click "Start" on the upper right side of the computer screen, and the instrument enters the analysis phase. as shown in Figure 5-6:

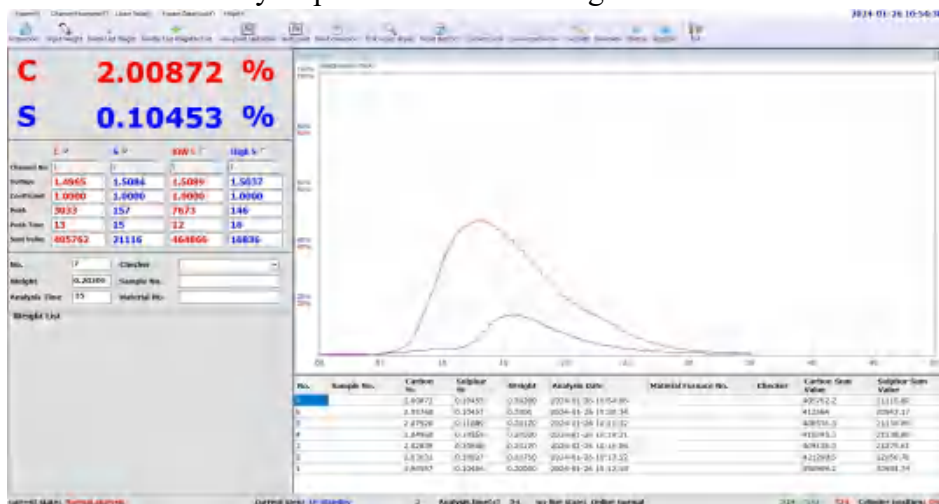

Figure 5-6 Instrument analysis process

Briefly describe its analysis process

1. The initial stage of analysis is the pre-blowing phase, in which the high-frequency furnace does not burn, and the pre-blowing time (countdown) is simultaneously displayed in the upper middle and upper parts of the computer analysis program. (The pre-blowing time can be set by the operator. The default time of the program is 15 seconds. Enter the channel parameter in the system menu to set the oxygen blowing time). Use the mouse to click the red "Stop Analysis" or press the computer "ESC" button to terminate the analysis process at any time.

2. Turn on High frequency furnace

When the pre-blowing oxygen countdown is 2s, the high-frequency furnace is turned

on. (The high-frequency furnace opening time is usually set to 35s. Enter the “Channel Parameter” in the “System Menu” to set the high-frequency furnace opening time), the real-time analysis curve display column 'starts to dynamically display the carbon (red) sulfur (blue) analysis curve, and the "analysis result column" starts to accumulate the detected percentage of carbon and sulfur. The analysis curve can store fifty pieces as needed, and multiple curves can be reproduced and compared.

3. End of analysis

At the end of the analysis, the ash discharge was performed for 2s. All the information of this analysis is displayed in the top column of the analysis result list at the bottom right of the screen.

5.4.2 One-point Calibration operation

After the instrument is turned on, do 2-3 waste samples, preheat the high frequency furnace, and then continue to do 2-3 standard samples. If the data is close to the standard value, you can test similar products, if the values and standards are obtained. If the values differ greatly, coefficient correction is required.

Step 1 Click “One-point calibration” in the tool bar above the desktop, as shown in Figure 5-7:

No.	Analysis Date	Carbon %	Corrected value	Sulphur %	Corrected value	Weight
6	2024-01-26 10:54:06	2.00872		0.10453		0.20200
5	2024-01-26 10:50:34	2.05768		0.10457		0.2005
5	2024-01-26 10:21:32	2.07926		0.11889		0.20170
4	2024-01-26 10:18:21	2.04968		0.10559		0.20020
3	2024-01-26 10:16:06	2.02839		0.10548		0.20170
2	2024-01-26 10:13:52	2.03032		0.10627		0.20750
1	2024-01-26 10:12:18	1.98957		0.10466		0.20050

Carbon standard value: C-Para 1.0000
 Sulfur standard value: S-Para 1.0000

Buttons: Revise, Save, Exit

Figure 5-7 One-point calibration

No.	Analysis Date	Carbon %	Corrected value	Sulphur %	Corrected value	Weight
4	2024-01-26 10:18:21	2.04968		0.10559		0.20020
3	2024-01-26 10:16:06	2.02839		0.10548		0.20170
2	2024-01-26 10:13:52	2.03032		0.10627		0.20750
1	2024-01-26 10:12:18	1.98957		0.10466		0.20050

Carbon standard value: C-Para 1.0000
 Sulfur standard value: S-Para 1.0000

Buttons: Revise, Save, Exit

Figure 5-8 Enter the correction value

Step 3 Enter the standard content, click “Revise” and then “Save”.

Step 4 Again do the standard sample, the data at this time is the data after the calibration.

5.4.3 Multi-point Calibration Operation

When testing an unknown content sample, its content value is uncertain. At this time, multi-point calibration can be used to determine the content of the material. If you know that the content range of the unknown sample is approximately 10% -50%, you can find three samples with low, medium, and high content, such as three samples with 5%, 35%, and 55% content. Of course, if there are more samples, you can select more samples, so the linearity of the data will be better, and the measured data will be more accurate.

Step 1 First test a few samples with different contents, at least three are required. Note that at this time, you need to test in a separate channel or a new channel that has not been used normally, and the coefficient cannot be corrected during the test, And the correction coefficients are all 1.000, as shown in Figure 5- 9:

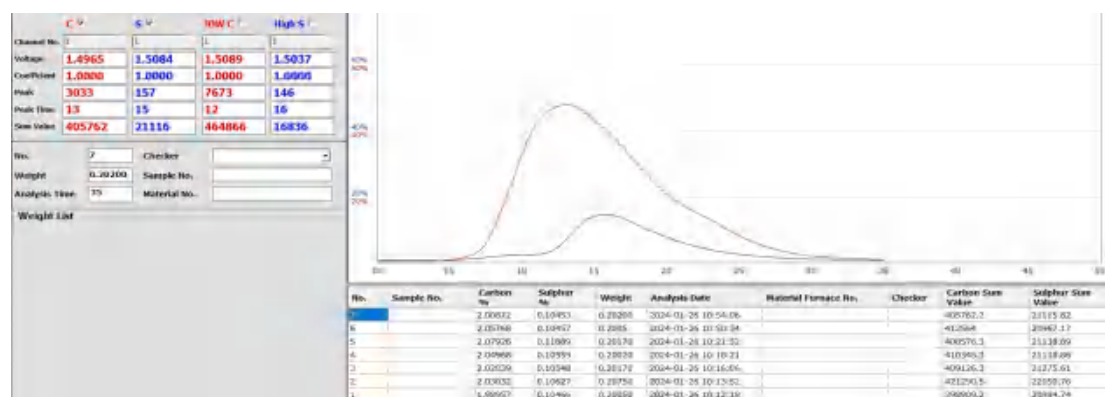

Figure 5-9 Test samples

Step 2 Click "System" and "Multi-point Calibration", as shown in Figure 5-10:

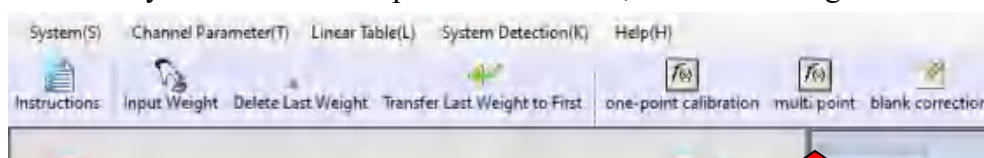

Figure 5-10 Multi-point correction

Step 3 Enter the password "123" to enter the calibration page, input the standard content of each sample correctly, and click the corresponding check mark at the back, as shown in Figure 5-11:

No.	Analysis Date	Carbon %	Carbon standard value	Corrected value	Sulphur %	Sulphur standard value	Corrected value	Weight
13	2024-01-26 11:11:18	<input checked="" type="checkbox"/>	1.48054	1.5	<input checked="" type="checkbox"/>	0.00534	0.0089	0.20150
12	2024-01-26 11:09:50	<input checked="" type="checkbox"/>	1.48629	1.5	<input checked="" type="checkbox"/>	0.00624	0.0089	0.20860
11	2024-01-26 11:08:09	<input checked="" type="checkbox"/>	0.12318	0.110	<input checked="" type="checkbox"/>	0.00873	0.011	0.40350
10	2024-01-26 11:06:39	<input checked="" type="checkbox"/>	0.17343	0.110	<input checked="" type="checkbox"/>	0.00895	0.011	0.40150
9	2024-01-26 11:05:08	<input checked="" type="checkbox"/>	0.02201	0.029	<input checked="" type="checkbox"/>	0.01012	0.013	0.40350
8	2024-01-26 11:03:39	<input checked="" type="checkbox"/>	0.02183	0.029	<input checked="" type="checkbox"/>	0.01003	0.013	0.43290
7	2024-01-26 10:54:06	<input checked="" type="checkbox"/>	2.00872	2.09	<input checked="" type="checkbox"/>	0.10453	0.120	0.20200
6	2024-01-26 10:50:34	<input checked="" type="checkbox"/>	2.05768	2.09	<input checked="" type="checkbox"/>	0.10457	0.120	0.2065
5	2024-01-26 10:21:32	<input type="checkbox"/>	2.07526		<input type="checkbox"/>	0.11889		0.20176
4	2024-01-26 10:18:21	<input type="checkbox"/>	2.04968		<input type="checkbox"/>	0.10559		0.20020
3	2024-01-26 10:16:06	<input type="checkbox"/>	2.02839		<input type="checkbox"/>	0.10548		0.20170
2	2024-01-26 10:13:52	<input type="checkbox"/>	2.03032		<input type="checkbox"/>	0.10627		0.20750
1	2024-01-26 10:12:10	<input type="checkbox"/>	1.98957		<input type="checkbox"/>	0.10466		0.20050

Figure 5-11 Entering the standard value

After all the steps 4 are completed, click “Calibrate”, and then enter the calibration page, select the appropriate degree of the equation respectively, until the standard The standard value and the correction value are the same. Click "OK", as shown in Figure 5-12:

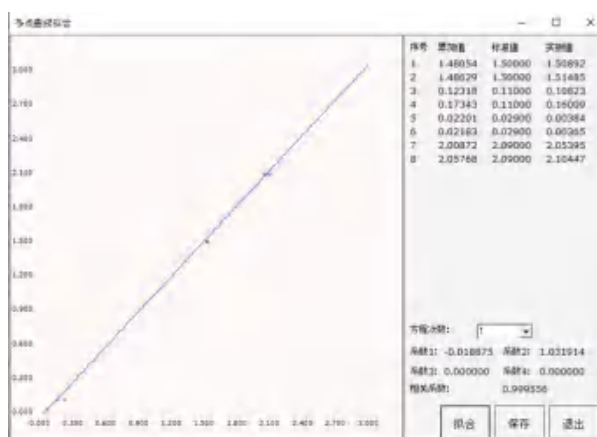

Figure 5-12 Calibration page

Step 5 after the correction is completed, and then test the unknown content of the sample is the content value of the sample.

5.4.4 Linear coefficient calibration operation

In the case of normal gas path and normal voltage signal, the infrared carbon-sulfur meter can be corrected by coefficient correction and linear correction if the data is incorrect. In most cases, only the coefficient correction is used. After the linear calibration is done, the standard is processed again. If there is no correction, if there is

any difference, it is better to use the coefficient correction to correct it, because the linear correction is the whole linearity. **It should be noted that the linear calibration needs to be contacted by the manufacturer's engineer and must be carried out under the guidance of a professional engineer to avoid problems with the entire linearity.**

Step 1 Click “Linear coefficient Calibration” under “Linear Table” on the homepage, as shown in Figure 5-13:

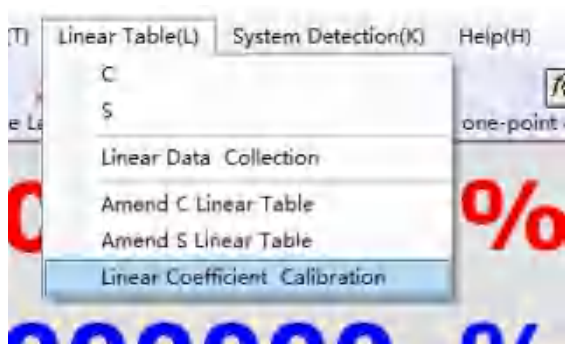

Figure 5-13 Linear coefficient

Step 2 Enter the password "QRgs" to enter;

Step 3 Check the data to be corrected, and enter the standard value. Click “Revise”, as shown in Figure 5-14:

No.	Analysis Date	Carbon %	Sulphur %	Weight
19	2024-01-26 13:08:13	0.02062	0.01105	0.40850
18	2024-01-26 13:05:33	3.50601	0.07365	0.20220
17	2024-01-26 13:02:15	3.32967	0.06660	0.20290
16	2024-01-26 13:00:11	3.30772	0.06580	0.20120
15	2024-01-26 12:57:12	0.02137	0.00977	0.40490
14	2024-01-26 12:55:12	0.02112	0.00981	0.41090
13	2024-01-26 11:11:18	1.48054	0.00534	0.20150
12	2024-01-26 11:09:30	1.46629	0.00524	0.20850
11	2024-01-26 11:08:09	0.12316	0.00873	0.40350
10	2024-01-26 11:06:39	0.17343	0.00895	0.40190
9	2024-01-26 11:05:08	0.02201	0.01012	0.40350
8	2024-01-26 11:03:39	0.02183	0.01007	0.43290
7	2024-01-26 10:54:06	2.00672	0.10451	0.20200
6	2024-01-26 10:50:34	2.05768	0.10457	0.2005
5	2024-01-26 10:31:30	2.07926	0.11889	0.20170
4	2024-01-26 10:18:21	2.04866	0.10556	0.20020
3	2024-01-26 10:16:06	2.02035	0.10548	0.20170

Carbon standard value: 5.45 C Para: 1.0000
 Sulfur standard value: 0.077 S Para: 1.0000

Buttons: Revise, Save, Exit

Figure 5-14 Linear Coefficient Calibration

5.4.5 Daily maintenance

During daily work, do 25 samples in a row, the system will prompt for dust removal, lower the burner, use a piece of paper or other utensils to catch the furnace mouth, press the automatic cleaning, clean the dust on the quartz tube, as shown in Figure 5-15:



Figure 5-15 Dust cleaning

Note:

After you do not need to use the instrument every day, you should turn off the high frequency furnace power switch, infrared host power switch, long press the balance power button to turn off the balance power, click the help in the toolbar above the desktop, click to exit the system, turn off the computer, turn off the oxygen cylinder master valve and loosen the oxygen adjustment knob counterclockwise.

When testing different content standards, you need to choose different reference channels yourself, as follows:

When testing high carbon and high sulfur standards, select 1-channel carbon and 1-channel sulfur.

When testing high-carbon low-sulfur standards, select 2-channel carbon and 2-channel sulfur.

When testing low-carbon and low-sulfur standards, select 3-channel carbon and 3-channel sulfur.

When testing low carbon and high sulfur standards, select 4-channel carbon and 4-channel sulfur.

Before each test, the corresponding carbon and sulfur channels should be selected. It should be noted that the selected reference channel is set by the customer. Each channel with a fixed content range can be determined according to the actual situation of the customer. This is beneficial to the data Stable and accurate.

5.4.6 How to Analyze Unknown Samples

CS8820T Carbon & Sulfur Analyzer is a relative measuring device. To obtain accurate test results with such an analyzer, it is necessary to use standard sample calibration. The basic process is: select measurement channel → analyze standard

sample → calibration → analyze the sample to get accurate results

1. CS8820T Carbon & Sulfur Analyzer has 10 channels with the same analysis parameters, and the user can perform standard calibration with different channels according to different materials.

2. Analysis of standard samples

Once the channel is selected, you can begin analyzing the standard sample. The standard sample selection method is: select the same or close to the material of the sample to be tested, that is, to analyze the steel sample, select the standard sample of the steel sample. To analyze the iron sample, select the standard sample of the iron sample. Similarly, if the sample is to be analyzed, it is best to use the standard sample. If there is no similar standard sample, the steel sample with similar content is generally used instead.

The carbon and sulfur content of the selected standard sample should be close to the sample to be tested and the content is preferably greater than the sample to be tested. It is recommended to input the carbon percentage of the sample to be analyzed in the sample identification column when analyzing the standard sample. Enter the sulfur content of the sample to be analyzed in the sample name field. It can be directly input in the sample identification and name quick input field on the analysis interface.

Analyze the standard sample (recommended at least twice). If the accuracy and repeatability of the analysis result meet the requirements, indicating that the calibration coefficient of the selected channel meets the standard sample, it is not necessary to enter the sample calibration stage, and the channel can be directly analyzed by the channel. The sample is measured and the result is the exact value of the sample being tested. If the accuracy and repeatability of the analysis result do not meet the requirements, indicating that the calibration coefficient of the selected channel is not suitable for the standard sample, enter the sample calibration stage. The reproducibility of the secondary analysis results meets the requirements, indicating that the analysis is effective and can be used as a calibration basis for the automatic calibration procedure. However, the carbon and sulfur results deviate from the standard value, indicating that the current correction factor of the device is incorrect and the coefficient correction is required.

3. Single point coefficient calibration and multi-point coefficient calibration

See Chapter 4, System Installation and Analysis Software Functions for details. If the analytical sample content is not wide, you can use the single point coefficient to correct the sample. If the content range is wide, it needs to be corrected by multi-point coefficient (Choose a low standard sample, a moderate standard sample, and a high standard sample. The more points, the more straight the curve is). After the coefficient is calibrated, you can see that the calibration coefficient has changed in the channel parameter table. The calibration process is completed. In this channel, the unknown sample can be analyzed with this calibration coefficient to obtain the accurate carbon and sulfur content of the unknown sample.

4. Analysis report

See Chapter 4, System Installation and Analysis Software Functions for details. Press the "F6" button or click the "Analysis Query" button, the screen displays the result

database data. Operators can query all the analysis data of the selected date according to the date you need to select. If you want to print, double-click the left mouse button on the “No” word in the “Print” column of the displayed data table to select the print, after selecting the right mouse button to display "Print Record" and then click "Print Record" to print

5.5 Analytical Experiment

5.5.1 Calibration Test

1. Blank test

When doing low-carbon and sulfur sample analysis, when adding other accelerators such as Sn and Fe, a blank test must be performed to obtain a blank value.

2. Calibration test

Before the sample analysis, after the stability test, the standard sample must be used for the calibration test.

Test results

1. The difference from the standard value is within the allowable error, and it is a non-systematic error. Only the accidental error distribution can check whether the correction coefficient is coded. If the deviation is necessary, the calibration test should be repeated. The operator can temporarily not make coefficient calibration. With the original coefficient, standard sample analysis can be performed during the analysis of the sample to observe the deviation from the standard value.

2. If there is an error with the standard value and it is a systematic error, if the distribution is not uniform, the coefficient should be corrected and then the verification test should be performed. If the result is satisfactory, the analysis sample with the new calibration coefficient can be started.

3. When the analysis interval is not long, the coefficient change will not be large. If the coefficient changes greatly, you should first find the cause of the abnormality. For example, consider the gas path, power supply, operation, sample, auxiliary materials, instrument parameters, etc.

5.5.2 Method Test

1. General metal material

Refer to the same material analysis method, weigh a small number of samples first, and observe the experimental situation.

2. General non-metallic materials

Refer to the same material, add pure iron flux, accelerate induction for analysis, and observe the experimental situation.

3. Observation of the experimental situation

Observation Aspect	Normal	Normal	Reason
Anode Current(Ma)	200~600	<200	Low sample volume, low power non-ferromagnetic sample

			>600	Excessive sample and flux
Release Curve	Double peak		Trailing	Release curve
			Double peak	
Curve	Peak time	10~15s	>20s	
	Release time	30~45s	>50s	
Melt shape		Smooth	Bubble	Low melt temperature (improper flux selection, etc.), low power
Analysis result		Good repeatability	Not good	The sample is not uniform, the treatment is not good, the analysis conditions are not good, the blank is unstable; the analysis content is outside the linear range.
		High recovery rate	Low recovery	Incomplete release, poorly handled samples are not handled well

4. Measure

Analysis of the cause of failure		Measure
Anode current is too low		Increase the amount of sample, or increase the acceleration dose
Anode current is too high		Reduce sample size(W, Fe, Sn)
Difficult to release		Several accelerators: Enhance the induction effect of the analytical system (Cu, Sn); reduce the melting point of the sample material, complete melting (Fe); carbon and sulfur solubility is favorable for carbon and sulfur release (W, Fe), and has a dilution effect, which can improve the melting point of the sample material and help release completely.
Bad repeatability	High content outside the linear range	Reduce sample size
	Low content, unstable blank	Porcelain crucible treatment in an oxygen-rich atmosphere; use high purity oxygen; appropriately extend some oxygen blowing time
	Sample processing is not good	Clean, re-sampling, baking, specification sampling
	Uneven sample	Take a large average; do more parallel analysis or ask the unit to resample.
	Accelerator quality, blank	Accelerators added should be selected

	instability	and tested for quality
	The instrument is not used for a long time.	Detectors, electronic components are damp or other reasons, using standard samples for laboratory inspection, and the maintenance personnel to cooperate with inspection or maintenance.
Low recovery	The system is not clean	Strengthen cleaning
	Matrix adsorption	Matrix vapor or its oxide adsorbs CO ₂ and SO ₂
	Low release rate	Reduce weighing; increase the addition of speed agent to increase the release rate

5. Description

Limited to the limited variety of contact samples of our company, the method test is only for user reference. Users are welcome to communicate with us and discuss and improve together.

5.5.3 Analysis and Judgment

After the analysis of the sample is completed, the results of the analysis should be judged and the results reported. Generally can be done as follows:

1. The deviation between the analysis results should be within the tolerance of the state.
2. Whether the analysis results are within the technical specifications of the analytical sample.
3. The accuracy of the same standard analysis is within the allowable range of the state
4. If the question must be re-examined, the analysis result can be reported.

Chapter 6 Maintenance and Simple Fault Diagnosis

6.1 Replacement Reagent

The instrument uses high-efficiency CO₂ absorbent, high-efficiency discoloration desiccant and quartz wool in the pneumatic system. When these reagents are knotted or discolored, they should be replaced in time. After replacement, the system must be checked for leaks;

Step 1 First of all, push the “Raise/Furnace key”, drop with the Crucible Holder, and then turn off the power gas, as shown in figure 1-1, 1-2:

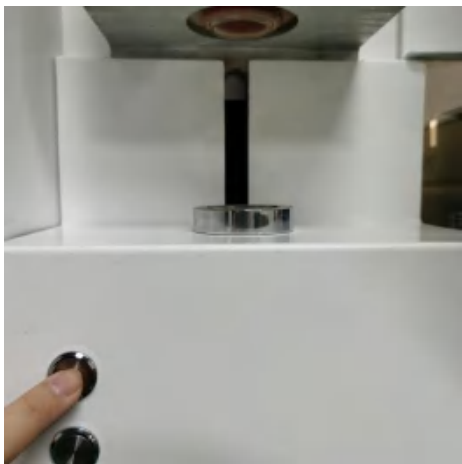

Figure 1-1 push the “Raise/Furnace key”



Figure 1-2 turn off the power gas

Step 2 Remove the “O” type sealing ring under the quartz tube and the gas pipe remove the Furnace Head, as shown in figure1-3,1-4:



Figure1-3 remove the “O” type sealing ring



Figure1-4 remove the Furnace Head

Step 3 Remove the quartz combustible tube, placed in (1: 3) Hydrochloric acid solution soak the quartz combustible pipe, heating to 60 ° C ~ 80 ° C, as shown in figure 1-5:

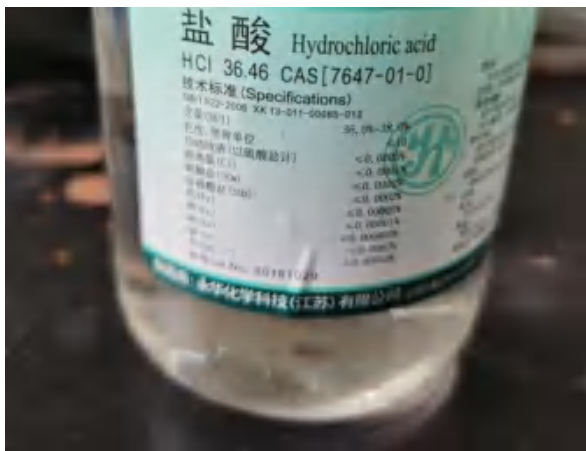

Figure1-4 Hydrochloric acid

Step 4 When the sputter of the surface of the quartz burning pipe is basically cleared, the quartz burning tube is removed and it was cleaned with water, as shown in figure 1-6:



Figure1-6the quartz burning tube was cleaned with water

Step 5 Use a tube brush to remove residual dirt, as shown in figure 1-7:



Figure 1-7 tube brush

Step 6 Put the quartz combustion tube in the drying oven to dry, as shown in figure 1-8:



Figure 1-8 drying oven

Step 7 Install the combustion tube, furnace head cleaning assembly and "O" type sealing ring (the inner wall of the sealing ring is coated with a thin layer of vacuum silicone grease), as shown in figure 1-9:



Figure 1-9 vacuum silicone grease

Step 8 perform a gas leak check.

6.2 Cleaning Filter Screen and Infrared Analysis Chamber

The Furnace Filter Screen is very easy to stay dust, you should pay attention to timely cleaning about once month. If the dust is more, the need for shortening the cleaning cycle. The cleaning step is as follows:

Step 1 Turn off the power gas, and Pull out the 4 gas tubes,as shown in figure 2-1:



Figure 2-1 Pull out the Furnace head

Step 2 Take Furnace head out the machine,as shown in figure2-2:



Figure 2-2 Furnace head

Step 3 You should to pull out the Oxygen bottle the red gas tube what connect the machine, and make it to install the Furnace head 's the blue interface, now, the cleaning system main pole will be come out by Oxygen gas, and adjust reducing valve left table the number about 0.3, as shown in figure 2-3:



Figure 2-3 adjust reducing valve

Step 4 Make the Oxygen bottle's red gas tube to connect to the front end of the Furnace head interface,the gas get through the front end of the Furnace head about 3 minutes, as shown in figure 2-4:



Figure 2-4 Cleaning the filter way

Step 5 Hold the front end of the Furnace head and rotate contrarotate with your left hand, and hold the front end of the furnace head and rotate clockwise rotation with your right hand, Slowly unscrew the middle end of the Furnace head,as shown in figure 2-5, 2-6 :



Figure 2-5 Before the Furnace head



Figure 2-6 After the Furnace head

Step 6 Use a wrench to clamp the flat surface of the front end of the furnace head, adjust the two wrenches to the appropriate size, rotate the left wrench to remove the end according to the position in the figure, and fix the main lever of the clearing system with the right wrench, as shown in figure 2-7, 2-8 :



Figure 2-7 main pole to break down



Figure 2-8 complete disassembly

Step 7 You need to take the Filter element out the Furnace head, and put the Filter element into the Ultrasonic cleaners to wash, as shown in figure 2-9, 2-10 :



Figure 2-9 the Filter element



Figure 2-10 take the filter out

Note:

During the disassembly process, if the quartz tube brush is found to be worn more seriously, a new net brush can be replaced.

Step 8 Apply vacuum silicone grease to both ends of the cleaned filter core about 30 minutes, as shown in Figure 2-11, and restore according to the original steps;



Figure 2-11 after the filter cleaned

Step 9 When roll back installation, you need pay attention to the filter head's installation sequence and position, as shown in figure 2-12: Put the Oxygen gas bottle's red tube to connect to the Furnace head's blue interface, then the Cleaning system main pole come back the original position, as shown in Figure 2-13:



Figure 2-12 pay attention to interface



Figure 2-13 when the gas tube to connect to main pole pack up automatically

Step 10 Put the Furnace head to install original position, two the rad gas tube and two the transparent gas tube to connect the original position, as shown in Figure 2-14:



Figure 2-14make the Cleaning system install original position, and check gas line whether isn't connect right

Due to the user misguided use of machine, for example , adjust the pressure to exceed the standard use range, the dust of the cleaning system will enter the Infrared Analysis Gas Chamber, the cleaning steps are as follows:

Step 1 Open the machine's left side cover, as shown in figure 2-15,2-16,2-17:

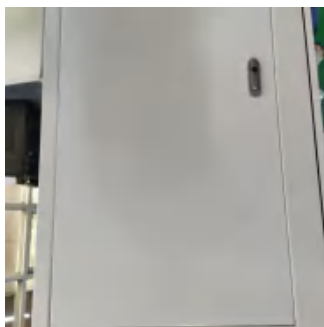

Figure 2-15 machine left side

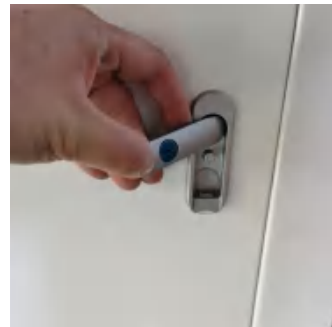

Figure 2-16 open the switch



Figure 2-15 open the cover

Step 2 Use a Phillips screwdriver to open the cover of the Infrared Analysis Gas Chamber, as shown in figure 2-18,2-19:



Figure 2-18 the front of cover



Figure 2-19 use a Phillips screwdriver to open

Step 3 Use a straight screwdriver to remove the Infrared Analysis Gas Chamber's data line, as shown in figure 2-20~2-25:



Figure 2-20 remove C data line

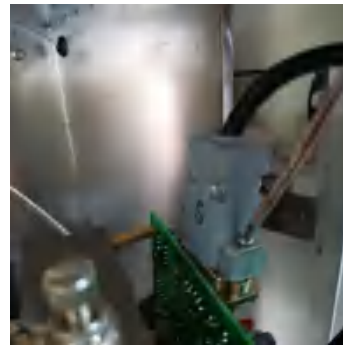

Figure 2-21 remove S data line



Figure 2-22 remove the white interface



Figure 2-23 remove the left interface

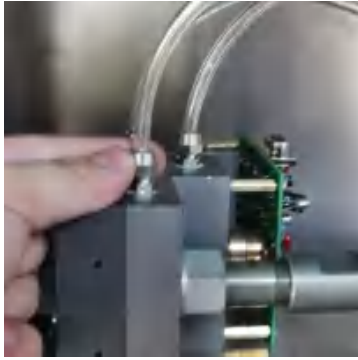

Figure 2-24 remove the gas interface

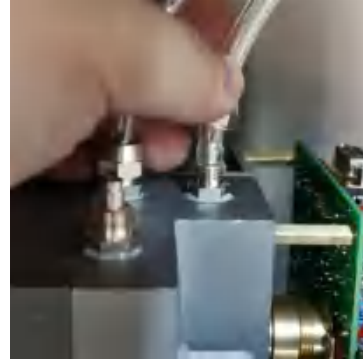

Figure 2-25 remove the gas interface

Step 4 Remove the Infrared Analysis Gas chamber, and adjust Oxygen Reducing Valve's left table to 0.1Mpa, as shown in figure 2-26:



Figure 2-26 adjust valve to 0.1Mpa

Step 5 Remove the red gas tube of the Oxygen Reducing Valve from the Total Oxygen Connector, and put it to connect to the left interface of the Infrared Analysis Gas Chamber, as shown in figure 2-27: then repeatedly and many times press the other interface with your finger to make the Oxygen gas flow change in the Interface Analysis Gas Chamber, so that a small amount of dust in the Infrared Analysis Gas Chamber is blown out, as shown in figure 2-28:



Figure 2-27 the Gas tube to connect to the interface

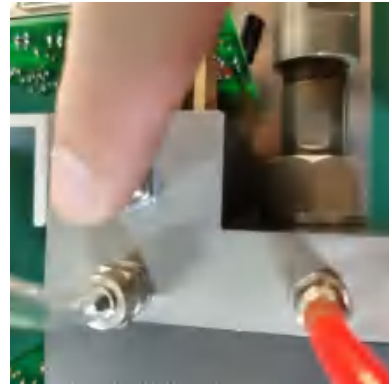

Figure 2-28 repeatedly press by your finger

Step 6 To make “the Infrared Analysis Gas Chamber”, “the Gas tube “, “data line “ to the Original position, you need to pay attention to “ left side is C data line, right side is S data line”, as shown in figure 2-29, 2-30:



Figure 2-29 the C data line of the Chamber left side



Figure 2-30 the S data line of the Chamber right side

6.3 Change the reagent

The instrument uses high-efficiency CO₂ absorbent, high-efficiency color-changing desiccant and quartz wool in the gas circuit system. These reagents should be replaced in a timely manner when they are hardened or discolored. After replacement, the system must be checked for leaks.

Step 1 Remove the reagent tube, as shown in figure 3-1:

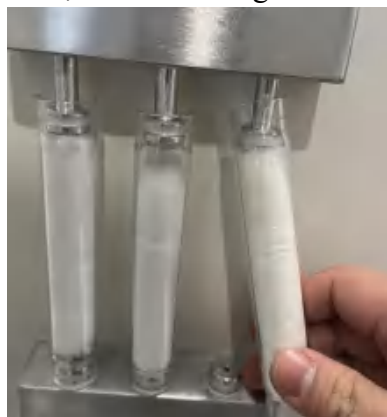

Figure 3-1 Reagent tube

Step 2 Use a tweezers take the the soda asbestos out the tube,as shown in figure 3-2:

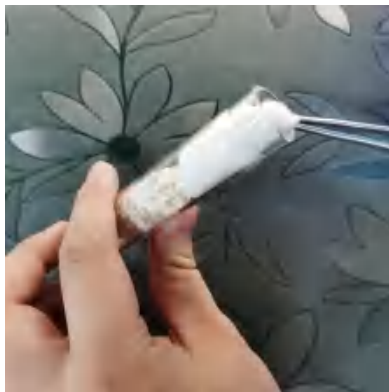

Figure 3-2 the soda asbestos

Step 3 remove the negates the effects of the reagent, and put the new reagent into the reagent tube,as shown in figure 3-2, 3-3:

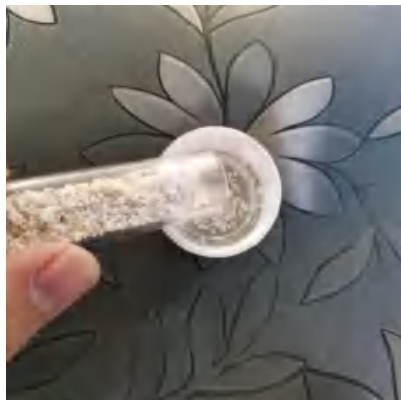

Figure 3-2 remove the negates the effects of the reagent

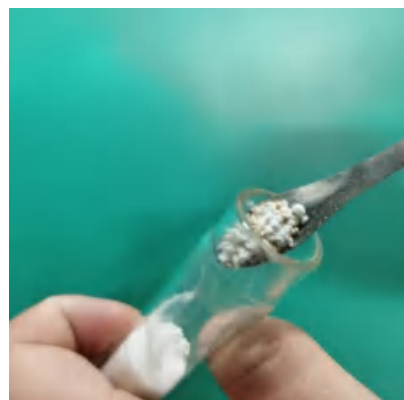

Figure 3-4 the new reagent

Step 4 Put the soda asbestos into the front end of tube, as shown in figure 3-5:



Figure 3-5 the reagent tube

Step 5 To install the reagent to the original position, and leak inspection, as shown in figure 3-6:



Figure 3-6 the reagent tube installation is finish

6.4 Leak inspection

If the data is still inaccurate when testing the standard sample after the coefficient correction, the leak may be caused. At the same time, if you use the instrument for a long time or hear the sound of obvious leak, you need to check the leak. Leak checks must be performed with sufficient oxygen and pressure.

Step 1 Open the software, click "Gas Path", then press the 12356 number key, and then press the "65321" number key, as shown in Figure 4-1:

Gas Path Detection(ESC-Exit)		
1	Total Gas Valve	Off
2	Blow Oxygen Valve	Off
3	Carry Oxygen Valve	Off
4	Clear Valve	Off
5	Entrance of Gasroom	Off
6	Exit of Gasroom	Off
7	Compact Ash	Off
8	High Frequency Furnace Switch	Off
9	Cylinder Signal	

Figure 4-1 leak inspection

Step 2 Observe that the pressure of the oxygen-loaded pressure gauge is 0.08. If the pressure does not drop within one minute, it means that there is no air leakage, as shown in Figure 4-2. If the pressure is slow, it means that there is a leak in the instrument and it needs to next check;



Figure 4-2 Carry Oxygen Pressure Meter

Step 3 Prepare two medical hemostatic forceps, which are indispensable check whether the air circuit is leak, as shown in Figure 4-3:



Figure 4-3 medical hemostatic forceps

Step 4 Bend the two analysis gas delivery tubes at the lower end of the furnace head, and clamp the bend with medical hemostatic forceps to make the air tightness here good, as shown in Figure 4-4: If the pressure gauge does not drop to 0, explain The oxygen-carrying valve, pressure gauge, and the three-way interface connected to it may be leaking, and then use medical hemostatic forceps to clamp one of the connected gas circuits to check one by one, as shown in Figure 4-5, 4-6: Use your ears to listen for any Obvious leakage of air, and observe the pressure gauge for obvious changes. If there is no change in the pressure gauge, it means that the top oxygen valve is leaking to the cleaning system or the air path from the cleaning system to the outlet valve of the air chamber. If a leak is detected somewhere, Just connect the analytical gas line

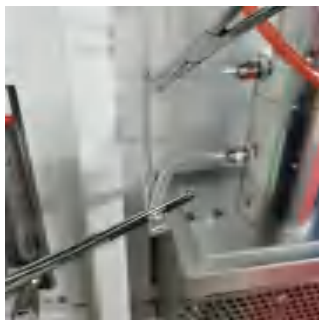

Figure 4-4 Clamped analysis gas tube



Figure 4-5 Clamped three-way connection
Oxygen carrier gas tube



Figure 4-6 the clamped pressure gauge
to the three-way gas tube

Step 5 Open the upper medical hemostatic forceps and observe whether there is a change in the pressure gauge. If there is no change, it means that there is no leakage from the top oxygen valve to the cleaning system. If the pressure gauge drops to 0, it means that the top oxygen valve is leaking from the cleaning system. Check the rear end of the top oxygen valve with a hemostat and check whether there is any air leakage in the top oxygen flowmeter. If a leak is detected somewhere, just connect the analytical gas circuit as shown in Figure 4-7:



Figure 4-7 the Oxygen Flow Meter to the Oxygen Valve the gas pipe

Step 6 Release the upper layer without air leakage, indicating that the cleaning system goes to the outlet valve of the air chamber to analyze air leakage somewhere, remove dust and purify the surface of the instrument. If the air leakage has obvious airflow sound, just place the sealing ring in the correct position That's it, as shown in Figure 4-8: other areas need to open the instrument shell and use medical hemostatic forceps to check whether the internal gas path is leaking. Because the operation is very complicated, the user needs to check and analyze the gas path diagram on page 7 of this book. Whether the gas path from the system to the air chamber outlet valve is leaking.



Figure 4-8 Purifier Tube if there are any obvious air leaks

6.5 Adjust Carbon and Sulfur pool voltage

It is necessary to adjust the pool voltage manually when the pool voltage with the change of time or incorrectly using the instrument and affects the data. The steps are as follows:

Step 1: open the Infrared Switch, as shown in Figure 5-1:

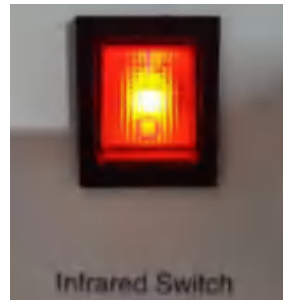

Figure 5-1 Infrared Switch

Step 2: Open the software, and observe the Carbon and Sulfur pool voltage, as shown in Figure 5-2:

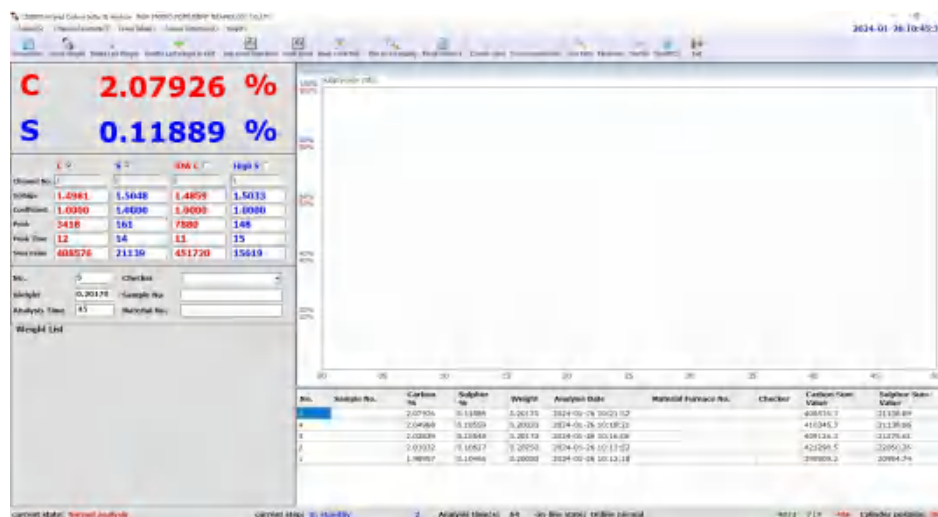

Figure 5-2 Observe the pool voltage

Step 3: Open the left door side of the instrument and to find the Infrared Analysis Chamber, as shown in Figure 5-3:

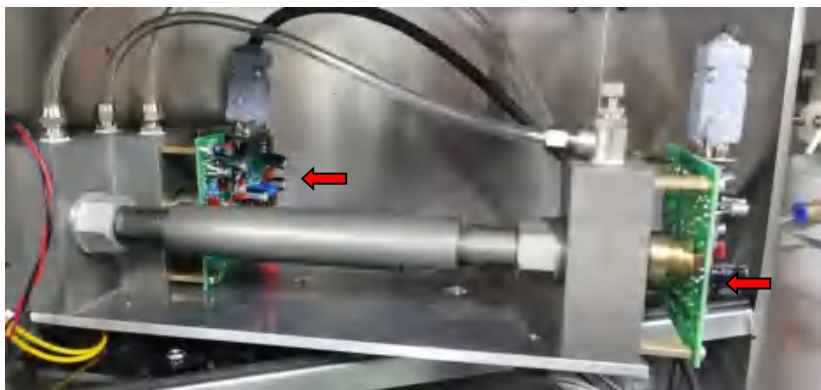

Figure 5-3 Infrared Analysis Chamber

Step 4: Adjust the Carbon and Sulfur pool voltage by rotating the magnifying board clockwise or counterclockwise with a slotted screwdriver. The pool voltage can be adjusted to about 1.5, as shown in Figure 5-4:

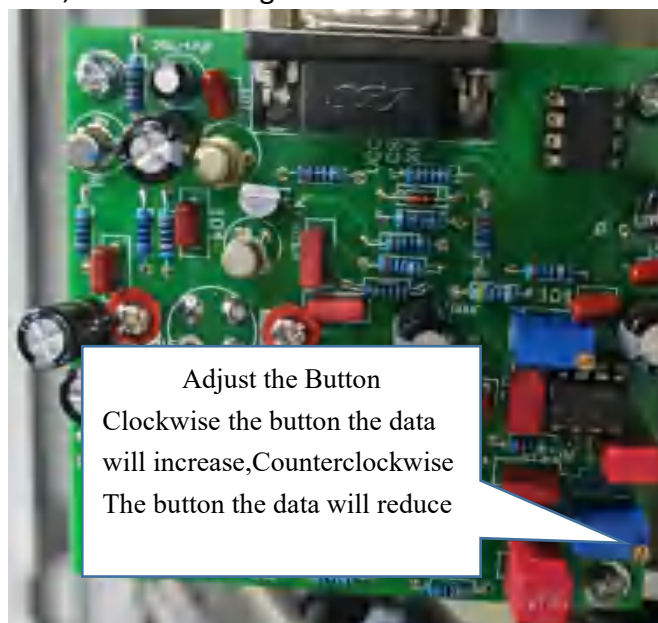

Figure 5-4 Adjust the pool voltage

6.6 Failure Phenomenon and Cause

Failure Phenomenon	Cause
Curve trailing	<ol style="list-style-type: none"> 1. Reagent failure 2. Porcelain crucible's processing method is wrong
The peak of the curve is obviously delayed	<ol style="list-style-type: none"> 1. No flux 2. Oxygen blockage
Analyze data drift	<ol style="list-style-type: none"> 1. Air chamber window leaks (move up) 2. The chamber temperature has not reached equilibrium 3. Pre-blowing oxygen time setting is too short (move down and then move up)
Analytical data fluctuations	<ol style="list-style-type: none"> 1. Large detector noise 2. Motor speed is unstable
The voltage signal does not jump and the control fails.	<ol style="list-style-type: none"> 1. Serial communication interruption 2. A/D board failure
The voltage signal is beating, but the voltage signal is small	Motor does not turn or shake
Analysis end load gauge pointer does not return to zero	Ash pipe clogging
Press the "dusting" button to not brush the ash	Porcelain crucible supporting does not touch limit switch

6.7 Frequently-used consumable items

The manufacturer recommends buy frequently-used consumable items, Save transportation cost and replace damaged parts immediately.

2024 consumable items price list

Serial No.	Item name	Unit	Unit price	Remark
961503	Ceramic Crucible	1000Pcs/box	100.00 USD	Size: 25mm*25mm
961520	Tungsten Accelerator	1000g/bottle	80.00 USD	-20~+40mesh W \geq 99.95% C<0.0008% S<0.0005%
961516	Pure Iron Accelerator	100g/bottle	20.00 USD	Carbon<0.002% Sulfur<0.002%
961504	Desiccant	50g/bottle	40.00 USD	About 20 mesh
961517	Quartz Combustion Tube	Pcs	60.00 USD	Length:172mm Big head outer diameter:43mm Big head inner diameter:38mm Small head outer diameter:35mm Small head inner diameter:32mm
981703-1	Ceramic Crucible Holder	Pcs	16.50 USD	
961519-2	Silicon Ring	Pcs	6.50 USD	40*27*27mm
961519-3	Silicon Ring	Pcs	0.90 USD	16×2.5 mm
961519	Steel Wire Brush	Pcs	7.00 USD	Round
961504-2	Discharging dust tube	Meter	9.00 USD	Used for instrument dust removal 14×8mm
981713-2	Metal Dust Filter	Pcs	160.00 USD	

Drawell International Technology Limited

**Shanghai Drawell Scientific Instrument
Co.,Ltd.**

Chongqing Drawell Instrument Co.,Ltd.



Add: Suite 2204, Building No. 11, Shiyou Road No. 1, Yuzhong District,
Chongqing, China

Tel: 0086-023-63268643

Web : www.drawell.com.cn

Email : sales05@drawell.com.cn