

# User Manual

## DW-GC 1290 Gas Chromatography



Please read operating manual before installation and operation.

**Drawell International Technology Limited**

**Shanghai Drawell Scientific Instrument Co.,Ltd**

**Add** : Suite 1506,Lane581 XiuChuan Rd.,PuDong New Area,Shanghai,China

**Tel**: 0086 21 50966080

**Fax**: 0086 21 50966080

**Web** : [www.drawell.com.cn](http://www.drawell.com.cn)

**Email** : [sales01@drawell.com.cn](mailto:sales01@drawell.com.cn)

## Print statement

The contents of this instruction will be revised without notice.

No warranty can be made on the marketability and applicability of the materials of this instruction for other purposes. We shall not be responsible for any accident or damage caused by this kind of use of this instruction.

Without the prior written consent, part or all of the instruction is not allowed to copy, reproduced or translated into other languages.

## Safety instructions

A warning message is to warn you of the circumstances and conditions that may cause you or others to be harmed or cause damage to the instrument.

An instruction message is to remind you of important information or attention that may affect the normal working environment and condition of the instrument.

# List

## 1. Overview

1.1 Technical specifications and using requirements .....	3
1.2 Complete set of instrument and optional accessories .....	5
1.3 Working principle of the instrument .....	5
1.4 Structure of the host machine .....	6
1.5 Warnings and precautions .....	7

## 2. Operation interface

2.1 Interface description .....	9
2.2 Main machine operation .....	21

## 3. Instrument installation and operation

3.1 Power requirements .....	27
3.2 Preparation and treatment of gas source .....	28
3.3 Connection of external gas circuit .....	29
3.4 Installation of packed columns .....	32
3.5 Install capillary column .....	36
3.6 Connect chromatograph software .....	38

## 4. Detector system

4.1 FID .....	39
4.2 Connection of FID and main machine .....	41
4.3 FID micro current amplifier .....	42
4.4 FID constant temperature analysis operation .....	43
4.5 FID temperature programming analysis operation .....	43
4.6 FID detector using precaution .....	44

## 5. Injector system

5.1 Packed column injector .....	47
5.2 Capillary injector .....	48

5.3 Introduction of capillary flow.....	49
5.4 Installation of capillary injector.....	49
5.5 Precautions of capillary column analysis operation.....	50
5.6 The use of the soap film flowmeter.....	51

## 6. Maintenance of the instrument

6.1 Maintenance of instrument.....	53
6.2 Cleaning of hydrogen flame ionization detector .....	53
6.3 Injector cleaning.....	55
6.4 Chromatographic signal judgment and troubleshooting.....	56

## 1. Overview

GC1290 gas chromatography is a high performance, general purpose, fully automatic gas chromatograph. It has many advantages, such as high stability, high reliability, compact structure and it is easy to operate. It can be used in wide fields: environment pollution trace analysis, poison analysis and research, clinical application, pathology and virus research, food fermentation, petroleum processing, oil analysis, geology and prospecting research, organic chemistry, synthesis research, health quarantine, and etc. The main features of GC1290 gas chromatography are as follows:

- 1) The microcomputer temperature control system has excellent performance: high temperature control precision (better than  $\pm 0.05^{\circ}\text{C}$ ), high reliability and high anti-interference capability. There are 6 separate temperature control zones. Maximum control temperature is up to  $420^{\circ}\text{C}$ . The limit temperature setting and over-temperature protection function insure the safe operation of this instrument.
- 2) Big touch screen display makes the display clearer, and the instrument is easier to be operated.
- 3) 2 channel packed-column injector or capillary split/ splitless injector units can be installed simultaneously, making double column detection possible.
- 4) 6 high performance detectors are available: FID、TCD、ECD、FPD、NPD and QMS. 3 detectors can be installed simultaneously (TCD is required). Besides, other detectors can also be installed if needed.
- 5) The gas circuit system is full digital control. Control mode, display, flow rate, pressure, split ratio and etc. can be changed through touch screen.
- 6) The large capacity column oven can accommodate capillary column and double packed column simultaneously. The oven can realize quick heating and quick cooling with auto-open back door mechanism. It can also achieve accurate room temperature control and 20 stages temperature program.
- 7) With the built-in collecting device, the instrument control state and the chromatographic output signal can be collected, and instrument real-time control (temperature control, detector selection and setting, gas circuit control and display) and data processing can be done through special chromatographic software.
- 8) The data processing includes dual channels (can be extended to more channels) high-speed acquisition of chromatographic data, automatic or manual setting of integral parameters, 5 quantitative methods, baseline subtraction, report establishment and etc.

## Notes

This operating manual is used for FID, capillary split/ splitless sample injector. Other detector or accessory operating manual will be provided with the item when they are selected.

## Notes

GC1290 Gas Chromatography implementation standards:  
Q31/0112000217C014-2016 (*GC1290 Gas Chromatography*). This standard accords with the newest version of following criterion:

GB/T 191-2000	<i>Graphic symbols for packaging and storage</i>
GB/T 2829-2002	<i>Periodic inspection sampling procedure and table</i>
GB/T 4793.1-2007	<i>Safety requirements of electrical equipment for measurement, control, and laboratory use</i>
GB/T 9969.1-1998	<i>Industrial product Instructions- general principles</i>
GB/T30431—2013	<i>Gas chromatography for laboratory use</i>
JB/T 9329-1999	<i>Instrument transportation and storage condition and test method</i>
JJG 700-2016	<i>Gas chromatography</i>

Each GC1290 Gas Chromatography has been tested strictly before delivery. The testing results and original chromatogram are attached. The testing result accords with the technical specification of the instrument and enterprise standard of Q31/0112000217C014-2016 (*GC1290 Gas Chromatography*).

## 1.1 Technical specifications and using requirements

### 1.1.1 Column oven temperature

Temperature range:	5°C above R.T.~420°C (0.1°C increment )
Temperature control accuracy:	better than ±0.05°C(at 200°C)
Program temperature rising:	20-stage program temperature rising
Program temperature rising rate:	0.1°C~ 40°C/min (0.1°C increment, measured at 200°C)
Thermostatic time per stage:	0~999 min (0.1 min increment)

### 1.1.2 Detector, injector, auxiliary temperature index

Temperature range:	7°C above R.T. ~420°C (0.1°C increment)
Temperature control accuracy:	better than ±0.1°C at 200°C

### 1.1.3 Hydrogen flame ionization detector

Detection limit:	$Dt \leq 5 \times 10^{-12} \text{g / s}$
Noise:	$\leq 3 \times 10^{-14} \text{A}$
Drifting:	$\leq 1.5 \times 10^{-13} \text{A/30min}$
Linearity range:	$\geq 10^6$
Maximum temperature:	400°C

### 1.1.4 Gas path control module (sample introduction)

Flow range:	0.1-1000mL/min (He, H <sub>2</sub> ) Factory default: He 0.1-200mL/min (N <sub>2</sub> , Ar) Factory default: N <sub>2</sub>
Pressure range:	0.1-100psi
Resolution setting:	0.1psi
Splitratio:	maximum 7500: 1

### 1.1.5 Gas path control module (detection)

Flow range:Air:	0.1-800mL/min
H <sub>2</sub> :	0.1-100mL/min
Tail-blowing:	0.1-100mL/min
Reference:	0.1-150mL/min
Input pressure range:	0.1-100psi
Resolution setting:	0.1psi

## Notes

The detector and the injector must be configured before use, and the control parameters of different components are different.

The packed column injector is usually installed at the rear sampler, and the capillary injector can be installed forward or rearward the sampling positions. Auxiliary temperature control can control the conversion furnace, thermal desorption instrument and other accessories.

It is suggested that the input pressure of various gases should be above 60psi, and if the pressure is too low, the effectiveness of flow and the output accuracy will be affected.

### 1.1.6 Requirements of instrument using

Power supply voltage:  $\sim 220V \pm 22V$   $50Hz \pm 0.5Hz$

Total power of instrument:  $\geq 2000W$

Ambient temperature:  $5^{\circ}C \sim 35^{\circ}C$

Relative humidity:  $\leq 85\%$

There is no electromagnetic interference, no corrosive gas and no strong vibration around the instrument.

The table should be stable and there must be no vibration.

There should be no corrosive gas in the room, and no electric furnace and tinder can be made within 2m of the hydrogen cylinder.

## Notes

The instrument has a high requirement for the power supply grounding, and the power supply of the place where the user places the instrument needs to have good grounding.

Generally, the following methods can be used to measure the voltage: the three core power line should be inserted into the power supply, and then measure the output outlet by multimeter. Measurement requirement:

Fire – ground 220V; Zero – ground  $< 3V$ ; Fire – zero 220V.



## 1.2 Complete set of instruments and optional accessories

GC1290 has a product line. It can be configured and purchased according to the user's needs.

The instrument provides a complete set of accessories for initial installation, such as: air purifier, pipes, wrench tools, injection needles and various types of joints. Users only need to prepare air source. (Please see the attached list of spare parts)

The following attachments are available for selection. You can make a clear note when ordering the machine.

- 1) GC1290 various detectors (including gas circuit module)
- 2) Six way plane switching valve gas injector
- 3) Conversion oven (including Conversion agent of Methanation nickel)
- 4) Thermal desorption
- 5) Deoxidizing tube

## 1.3 Working principle of the instrument

Gas chromatograph takes gas as mobile phase (carrier gas). When the sample is injected into the injector by micro syringe, then it will be carried into the packed column or capillary column by carrier gas. The difference in the distribution or adsorption coefficient between the mobile phase (gas phase) and stationary phase (liquid phase or solid phase) in the sample column, under the condition of carrier gas washing, each component was distributed repeatedly between two phases. The components were separated in the column. Then the components can be detected in sequence according to the physical and chemical properties of the components by detector connected after the column. The principle diagram is as follows.

## 1.4 Structure of the host machine

GC1290 consists of detector, injector, column oven, gas path control unit, temperature control device, detector electrical circuit control unit, and etc. The middle part is the chromatographic column oven, the right part is electrical circuit control part, the front right is the touchable LCD screen. The upper back is the flow control unit. The upper middle part of the column oven is the installation position of detector. The upper left part of the column oven is the installation position of double packed column injector and capillary injector

### 1.4.1 Column oven

GC1290 has large volume, it is easy to install capillary column or double packed column, and has speedy ramping and cooling. Column oven heating wire is hidden behind the board, so the peak split of the elastic silica capillary column caused by heating wire radiation can be avoided. GC1290 uses low noise motor, making the operation very smooth and machine shock very small. When column oven needs cooling, the cooling air inlet and the hot air outlet at the back of the oven will open automatically. Then the cooling air enters the column oven from the air inlet and replace the hot air in the column, cooling down the column oven rapidly.

The total heating power of the column oven heating wire is about 1500W, column oven structure is as follows.

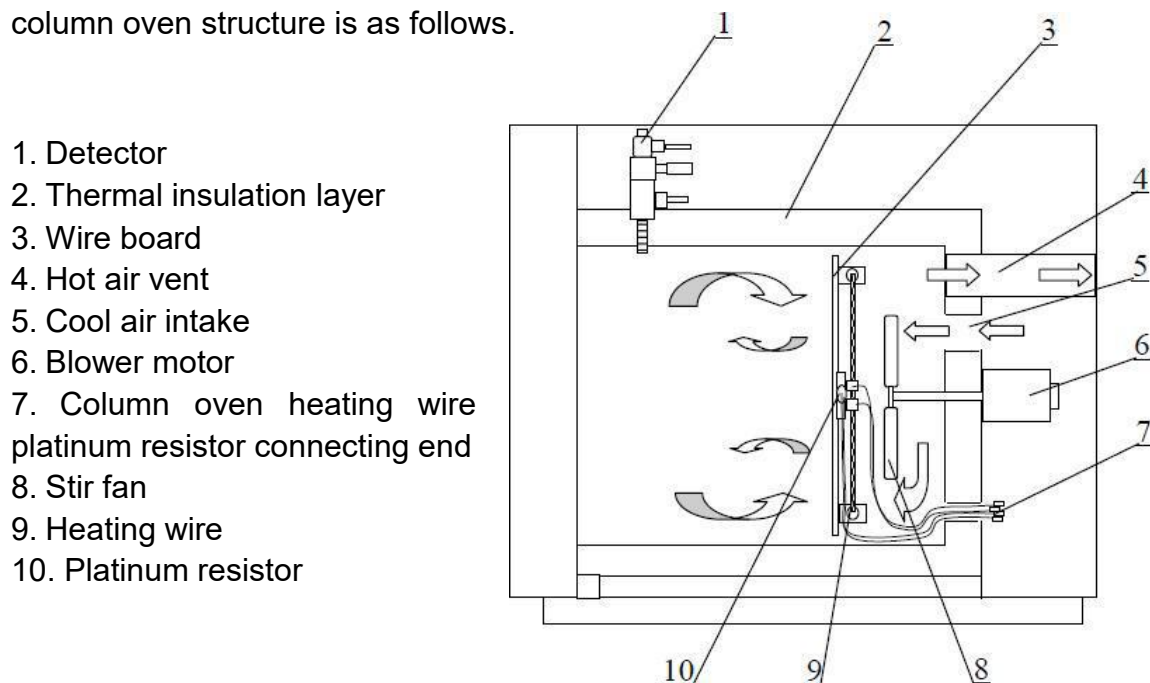

## 1.4.2 Injector

The instrument can simultaneously install 2 kinds of injector, that is: single packed column / double packed column injector and capillary column injector.

## 1.4.3 Gas circuit control system

GC1290 gas circuit control system is totally digital modular control, users can set the related parameter by the touch screen or control software and see the real-time value.

Different gas path control module is designed according to different injector and detector configuration. The machine can install 2 injection modules and 3 testing modules at most.

## 1.5 Warnings and precautions

### 1.5.1 Dangerous voltage

Many internal components of GC1290 have dangerous voltages. If the instrument is connected to the power supply, even if it is not switched on, the potential dangerous voltage can be found in the following places: instrument inlet socket, power switch, filter, fuse holder, Silicon control plate and wires that connect these components.

When the power is switched on, the potential dangerous voltages can also be found in the following places: all the electrical circuit boards in the instrument, internal wires and cables connected to these circuit boards, especially the detector board with high pressure and color LCD backlight drive panel

Note: In order to avoid the risk of electric shock, before opening the back cover or side plate to replace the parts, Switch off and remove the power cord, and wait for a few minutes to start the next operation. If the power cord is worn or chafed, it must be replaced

### 1.5.2 Static discharge

Static discharge is a threat to the electronic components of GC1290, which can damage the circuit board. Do not touch any circuit board unless absolutely necessary. If you have to move or replace the circuit board, use a grounding strap and do other antistatic preparations.

### 1.5.3 High temperature area

The temperature of many components of the GC1290 are high enough to cause severe burns. These components include (but not limited to these) :

1. Injection port
2. Internal and external part of the column oven.
3. Detector collection head
4. The column nut of the connection column and the injection port or detector
5. Rear door and column oven motor

Before working on these parts of the GC1290, try to wait as much as possible until it cools to room temperature. If you have to repair the hot parts, use a wrench or wear gloves.

### 1.5.4 Other dangers

The insulation material of the injection port, detector, column oven is made of refractory fiber. There is the danger of inhaling fiber particles during replacement. So proper protection must be done and wash your hands with soap immediately after processing.

## 2. Operation interface

### 2.1 Interface description

GC1290 gas chromatograph uses 7 inches, 640\*480 pixels LCD touch screen LCD. Users can get the operation information easily.

#### 2.1.1 Initial interface

Power on and turn on the switch of the instrument. Wait for a few seconds, the instrument will automatically enter the self-check interface.

#### 2.1.2 Self-check interface

The system will detect the setting project, after beeping the instrument will enter the main interface.

#### 2.1.3 Main interface

Main interface is the most important interface, and most of the functions are here. Any interface can eventually return to this interface

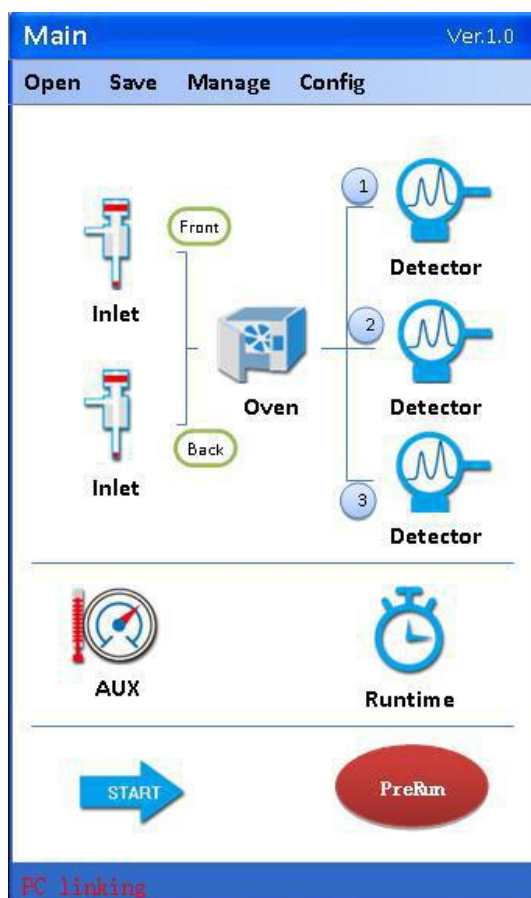

## 2.1.4 Configuration interface

This interface is to collocate the system according to the hardware. The configuration of the inlet and detector should be in accordance with the hardware, and this is always set before delivery.

### ◆ Inlet configuration:

Forward inlet	backward inlet
Split/ splitless inlet	Split/ splitless inlet
Large caliber capillary column/ packed column inlet	Large caliber capillary column/ packed column inlet
Non	Double packed column inlet

### ◆ Detector configuration:

Detector 1	Detector 2	Detector 3
FID	FID	TCD
ECD	ECD	Non
FPD	FPD	
NPD	NPD	

### ◆ Auxiliary configuration

Auxiliary selection box is used to select whether or not to use the auxiliary function. When you do not choose, the main interface auxiliary will display "no configuration", and cannot set the parameters. Auxiliary function can only be used when it is chosen

## 2.1.5 Column oven interface

### ◆ Column oven temperature

【Note】 Turn on the temperature switch and it will start heating. On the contrary, turn off the switch and it will stop heating.

【Note】 The set temperature should not exceed the maximum temperature.

【Note】 When the temperature does not reach the set temperature in a certain time, it will stop heating automatically.

◆ Maximum temperature: Set the maximum temperature of the column oven to prevent the damage. Setting temperature of column and program temperature rise should not exceed maximum temperature.

### ◆ Temperature mode

1. Constant-temperature mode: When this mode is chosen, the system will keep at set temperature. The temperature set in the program temperature rise meter will not work.

2. Program temperature rise control mode: When this mode is chosen, the program temperature rise meter will start work.

◆ Sampling synchronization: When sampling synchronization is chosen, data acquisition card will collect the data since operation starts.

◆ Program temperature rise operation status display—program rise operating stages information: constant temperature status, initial status retention, 1 stage temperature rise, 1 stage retention, 2 stages temperature rise, 2 stages retention and etc.

◆ Total stages: Program temperature rise total stage is calculated automatically and cannot be changed. (Total 5 stages)

◆ Program temperature rise meter: Used to set program temperature rise. 20 stages setting is possible. Input speed, arrival speed, and retention time, and stage number and total time will be calculated automatically. 12 lines is the maximum.

When program temperature rise data is filled, press “confirm”, then the data can be reserved. Please note, if “confirm” is not pressed, the data will lose after exiting this interface.

Each line should be filled, or the line after where the blank exits will all be lost after pressing “confirm”.

Data delete: Delete the data you do not want, and press “confirm”. Exit this interface and then come back, you will see the data you selected is deleted.

## 2.1.6 Injector interface

### 2.1.6.1 Split mode interface

◆ Carrier gas: N<sub>2</sub>, H<sub>2</sub>, He, Ar are possible.

◆ Column parameter: Press column parameter setting button. The column parameter setting includes column internal diameter, column length, film thickness, and outlet pressure. Ordinary pressure, vacuum and appointed pressure are optional for outlet pressure.

**Note:** Please set these parameters carefully, otherwise flow or pressure control might appear problems.

◆ Control mode: Constant flow volume, constant pressure, gradient flow volume, gradient pressure are optional.

Constant flow: Column flow volume is constant;

Constant pressure: Column head pressure is constant;

Gradient flow: Column flow volume is changeable as preset.

Gradient pressure: Column head pressure is changeable as preset. Choose different control mode, the flow setting content will also be different.

◆ Flow setting

(1) Constant flow control mode: Only split ratio and column flow volume can be set.

Total flow volume: Only display real-time total flow volume. Total flow volume=column flow volume\*(split ratio+1) + diaphragm blowing flow volume

Split ratio: Only set split ratio. Split ratio=split flow/ column flow volume

Diaphragm blowing: Only display real-time diaphragm blowing flow volume

Column flow volume: Display real-time column flow volume, set target column flow volume

Column head pressure: Only display real-time column head pressure

(2) Constant pressure control mode: Only split ratio and column head pressure can be set.

Total flow: Only display real-time total flow. Total flow=column flow\*(split ratio+1) + diaphragm blowing flow

Split ratio: Only set split ratio. Split ratio=split flow/ column flow

Diaphragm blowing: Only display real-time diaphragm blowing flow

Column flow: Only display real-time column flow

Column head pressure: Display real-time column head pressure, set target column head pressure.

(3) Gradient flow control mode: Only split ratio and flow gradient can be set. Press “flow gradient”, enter the setting interface.

Total flow: Only display real-time total flow. Total flow=column flow\*(split ratio +1)+ diaphragm blowing flow

Split ratio: Only set split ratio. Split ratio=split flow/ column flow

Diaphragm blowing: Only display real-time diaphragm blowing flow

Column flow: Only display real-time column flow

Column head pressure: Only display real-time column head pressure.

This instrument can preset 3 stages flow or pressure gradient, column flow or column head pressure can increase or decrease according to the setting time during the process.

Speed: Set flow/ pressure speed of each stage

Flow: Set column flow of each stage

Pressure: Set column head pressure of each stage

Retention: Set flow retention time of each stage

(4) Gradient pressure control mode: Only split ratio and pressure gradient can be set. Press “pressure gradient”, enter the setting interface.

Total flow: Only display real-time total flow. Total flow=column flow\*(split ratio+1)+ diaphragm blowing flow



Split ratio: Only set split ratio. Split ratio=split flow/ column flow  
Diaphragm blowing: Only display real-time diaphragm blowing flow  
Column flow: Only display real-time column flow  
Column head pressure: Only display real-time column head pressure.

◆ Carrier gas switch

◆ Carrier gas saving: Reduce the split ratio and carrier gas flowing through the shunt flow to save gas. Split ratio is changed, but column head pressure keeps constant. That is, changing the split ratio does not affect the carrier gas flow volume which flows through the chromatography.

When carrier gas saving is selected, split ratio and time should also be set.

Split ratio: Split ratio under carrier gas saving mode is suggested not lower than 15:1.

Time: The time from analysis start to split ratio switching to carrier gas mode should be longer than sample moves from injection port to column. If the gas saving time is too short, the quantitative result cannot be guaranteed.

◆ Maximum temperature: The injection port temperature should not exceed the maximum temperature of the injection port.

## 2.1.6.2 Split-splitless mode interface

Split-splitless mode: Switch off the split flow, and switch on again after setting time (splitless time)

Flow relation:

During splitless time: Total flow= column flow + diaphragm blowing flow

Other time: Total flow= column flow + diaphragm blowing flow + split blowing flow

◆ Flow volume setting

(1) Constant flow control mode: Only column flow can be set  
Total flow: Only display real-time total flow.

Diaphragm blowing: Only display real-time diaphragm blowing flow.

Column flow: Display real-time column flow, column flow setting is possible.

Column head pressure: Only display real-time column head pressure

(2) Constant pressure control mode: Only column head pressure can be set

Total flow: Only display real-time total flow.

Diaphragm blowing: Only display real-time diaphragm blowing flow.

Column flow: Only display real-time column flow.

Column head pressure: Display real-time column head pressure and column

head pressure setting is possible.

(3) Gradient flow control mode: Only flow gradient can be set.

Total flow: Only display real-time total flow.

Diaphragm blowing: Only display real-time diaphragm blowing flow.

Column flow: Only display real-time column flow.

Column head pressure: Only display real-time column head pressure.

(4) Gradient pressure control mode: Only pressure gradient can be set.

Total flow: Only display real-time total flow.

Diaphragm blowing: Only display real-time diaphragm blowing flow.

Column flow: Only display real-time column flow.

Column head pressure: Only display real-time column head pressure.

◆ Splitless time: Set splitless time. The time ranges from injection start to shunt closure.

◆ Split blowing flow: Set split blowing flow. After splitless time, open the split flow.

◆ Maximum temperature: Set maximum temperature. The temperature of the injection port should not exceed the maximum temperature.

◆ Carrier gas saving:

The carrier gas saving function is similar to split mode, only different in the definition of time

**Note:** If the total flow is small, it would be hard for column head pressure to reach the set value in a short time and the system will report the error. If it cannot reach the set value for a long time, the process will stop automatically. It is suggested that the user increases the split ratio, and when the gas circuit become stable, revise the split ratio back to needed value.

## 2.1.7 Interface of detector

◆ Detector number display

Display current detector number: detector 1, detector 2

◆ Detector temperature

Display real-time temperature of the detector.

Set the temperature of the detector.

**Note:** The set temperature should not exceed the maximum temperature.

**Note:** If the temperature do not reach the set temperature in certain time, it will stop heating automatically.

◆ Hydrogen

Hydrogen real-time flow display and set  
Hydrogen switch and status display

◆ Air

Air real-time flow display and set  
Air switch and status display

◆ Make-up gas

Make-up gas real-time display and set  
Make-up gas switch and status display

◆ Measuring range

Measuring range selection. (Can choose only one)

◆ Polarity

Switch on or off.

◆ Fire up

Press the button, if not succeed in firing up, wait 10 seconds until the button turn back to the original status, and press again.

◆ Zero setting

Display real-time base flow volume  
Base flow adjustment has 2 modes: coarse tuning and fine tuning. The up arrow means increase, while down arrow means decrease.

◆ Maximum temperature

Set the temperature upper limit of the injection port, and it should not exceed the maximum temperature of the injection port.

## 2.1.8 Auxiliary interface

◆ Auxiliary temperature

Display auxiliary real-time temperature.

Note: Auxiliary temperature should not exceed maximum temperature..

◆ Auxiliary flow

Display auxiliary real-time flow  
Set auxiliary flow

◆ Maximum temperature

Set the auxiliary temperature upper limit, which should not exceed the maximum temperature.

## 2.1.9 Parameter management

### 2.1.9.1 Select the parameters

Open the file which is reserved as operation parameter. The maximum file number is 10.

Record-n (n=0,...,9) is the reserved file of parameter.

<Empty> is empty file, do not choose it.

#### ◆ File selection

The selected file will display ✓, and the name of the file will show in the text box.

### 2.1.9.2 Save parameters

Touch the “save” on the main interface

Save the operating system parameter. The maximum file number is 10.

Record-n (n=0,...,9) is the reserved file of parameter.

<Empty> is empty file.

#### ◆ File selection

The selected file will display ✓, and the name of the file will show in the text box

#### ◆ Save the file

Press “save” to save the parameter. Close current picture and go back to main interface.

If choose “empty” file, the name of the file will be changed into Record-n (n=0,1,...,9). For example ”1 Record-1”;

If choose the parameter file which has been reserved before, the new data will cover the original data, while the name stays the same.

#### ◆ Cancel

Press “Cancel”, close current picture and go back to main interface.

### 2.1.9.3 Management interface

This interface is used to delete the parameter file which is reserved.

Record-n (n=0,...,9) is the reserved parameter file.

<Empty> is empty file

#### ◆ File selection

Press the file you want to delete, the chosen one will display ✓, and the name of the chosen file will display in the text box.

◆ Delete the file

Press “delete”, delete the selected file.

◆ Cancel

Press “Cancel”.

### 2.1.10 Statement interface

Touch the statement display area at the central of the bottom part in the main interface.

It will display set data of the column oven, injection port, the temperature of the detector, real-time value and set value of the flow. The set value here cannot be changed.

The display content (injection port and detector) is modified automatically according to the configuration of the instrument. The content is as below.

Name	Display menu
Column oven	Temperature
Split / splitless injection port	Temperature
	Total flow
	Column head pressure
Large diameter capillary column / packed column inlet	Temperature
	Total flow
	Column head pressure
Double packed column inlet	Temperature
	Column A flow
	Column B flow
FID	Temperature
	Hydrogen flow
	Air flow
FPD	Temperature
	Hydrogen flow
	Air flow
ECD	Temperature
	Make-up gas flow
	Auxiliary
NPD	Temperature
	Hydrogen flow
	Air flow
TCD	Temperature

### 2.1.11 Time interface

This interface is used to set the operation event. The maximum set number is 10.

Method: Input the time, choose the parameter and set value of the instrument, and press “add”.

#### ◆ Time

Input time, the set will be executed after the time passed.

#### ◆ Instrument parameter

Choose the instrument: valve 1 or valve 2.

#### ◆ Set value

Choose switch on/off

#### ◆ “Add”

“Add”: Add the event to be executed. Input time, choose instrument parameter and set value. And then press “add”. When the file reaches 10, it cannot be added more, please empty or delete some of the data.

#### ◆ “Empty”

“Empty”: Used to empty the whole content of the event list. This operation cannot be recovered, please note.

#### ◆ “Delete”

“Delete”: Used to delete the selected line. This operation cannot be recovered, please note.

### 2.1.12 Time interface

Press the time displayed in the bottom right-hand corner.

This interface displays the current date and time.

#### ◆ Reset

“Reset”: Used to reset the date and time.

### 2.1.13 Error message

When the system detect the mistake during the launch, it will displays error messages and beeps.

Press “Confirm” and close this interface. Go back to main interface and turn off the warning sounds.

## Error message

	<b>Warning message</b>	<b>Treatment</b>
1	Measuring temperature of the column oven exceed the set maximum use temperature	a. Increase maximum use temperature b. Reduce set temperature
2	Column oven temperature measurement short-circuit	a. Inspect platinum resistance value to the ground b. Inspect platinum resistance value
3	Column oven temperature open circuit	a. Inspect platinum resistance value
4	The door of the column oven is not closed. (At heating state)	a. Close the door b. Stop the column heating
5	Column oven heating overtime	a. Inspect whether the back door is closed b. Reduce heating rate c. Inspect the status of heating wire
6	Column oven cooling overtime	a. Inspect whether the back door is opened b. Stop column heating
7	Column oven heating is abnormal	a. Inspect platinum resistance value b. Inspect column heating board
8	Injection temperature exceeds the set maximum use temperature.	a. Increase maximum use temperature b. Reduce set temperature
9	Injection temperature short-circuit	a. Inspect platinum resistance value to the ground b. Inspect platinum resistance value
10	Injection temperature open circuit	a. Inspect platinum resistance value
11	Injection temperature exceeds the set maximum use temperature.	a. Increase maximum use temperature b. Reduce set temperature
12	Detector temperature short-circuit	a. Inspect platinum resistance value to the ground b. Inspect platinum resistance value
13	Detector temperature open circuit	a. Inspect platinum resistance value

14	Auxiliary temperature exceeds the set maximum use temperature	<ul style="list-style-type: none"> <li>a. Increase maximum use temperature</li> <li>b. Reduce set temperature</li> </ul>
15	Auxiliary temperature short-circuit	<ul style="list-style-type: none"> <li>a. Inspect platinum resistance value to the ground</li> <li>b. Inspect platinum resistance value</li> </ul>
16	Auxiliary temperature open circuit	<ul style="list-style-type: none"> <li>a. Inspect platinum resistance value</li> </ul>
17	Injection flow volume not ready	<ul style="list-style-type: none"> <li>a. Whether the carrier gas is open</li> <li>b. Whether the column parameter is set correctly</li> <li>c. Whether the injection leaks gas</li> <li>d. Whether the parameter is set correctly</li> <li>e. Whether the column is installed correctly</li> </ul>
18	Injection pressure not ready	<ul style="list-style-type: none"> <li>a. Whether the carrier gas is open</li> <li>b. Whether the column parameter is correctly set</li> <li>c. Whether the injection leaks gas</li> <li>d. Whether the parameter is correctly set</li> <li>e. Whether the column is correctly installed</li> </ul>
19	Detector FID hydrogen flow not ready	<ul style="list-style-type: none"> <li>a. Whether the hydrogen is open</li> <li>b. Whether the hydrogen inlet leaks gas</li> <li>c. Whether the parameter is correctly set</li> <li>d. Whether the hydrogen pressure reaches the standard</li> </ul>
20	Detector FID air flow not ready	<ul style="list-style-type: none"> <li>a. Whether the air is open</li> <li>b. Whether the air inlet leaks gas</li> <li>c. Whether the parameter is correctly set</li> <li>d. Whether the air pressure reaches the standard</li> </ul>



21	Detector FID auxiliary flow not ready	<ul style="list-style-type: none"> <li>a. Whether the auxiliary gas is open</li> <li>b. Whether the auxiliary gas inlet leaks gas</li> <li>c. Whether the parameter is correctly set</li> <li>d. Whether the auxiliary gas pressure reaches the standard</li> </ul>
22	Data cannot be set! Already been locked by upper computer software, please use the upper computer to operate it.	<ul style="list-style-type: none"> <li>a. Use computer software to operate it</li> <li>b. Disconnect the main machine and computer.</li> </ul>

### 2.1.14 Touch screen calibration

1. Rapidly click the touch free area of the touch screen more than 20 times in 4 seconds, then will enter the touch screen calibration mode.
2. Stop clicking when the buzzer rings.
3. Enter the calibration mode, click the screen as indication to calibrate the instrument.
4. When the calibration is done, return to the previous interface.

## 2.2 Main machine operation

### 2.2.1 Switch on

The switch is at bottom right of the main machine. The microcomputer will introspect and initialize after 1 minute.

### 2.2.2 The setting during sample analysis process

#### 2.2.2.1 Constant temperature analysis

Main machine temperature control realization needs constant temperature set for the injection and detector. Set the initial temperature of the column oven as needed temperature for constant temperature analysis. (**Note:** The set temperature of the injection should exceed the initial temperature of the column oven 30°C). When the temperature and output signal of the detector stabilizes, the sample can be injected for analysis. Collect the signal while injecting. The chromatograph workstation will start integral processing and quantitative calculation.

FID standard sample test will be used as an example to illustrate the method of parameter setting.

Test condition: SE30 15m×0.32mm×0.5µm capillary column

Column temperature: 150°C; Detector: 220°C; Injection: 250°C;

Column flow: 2ml/min; Split ratio: 20: 1;

Hydrogen: 20 ml/min; Air: 200 ml/min; Make up gas: 20 ml/min;

Procedure:

1. Front inlet: split/ splitless inlet

Detector 1: FID



2. Press  on the main interface, set the parameter of the column:

Column inner diameter: 320

Column length: 15

Film thickness: 0.5

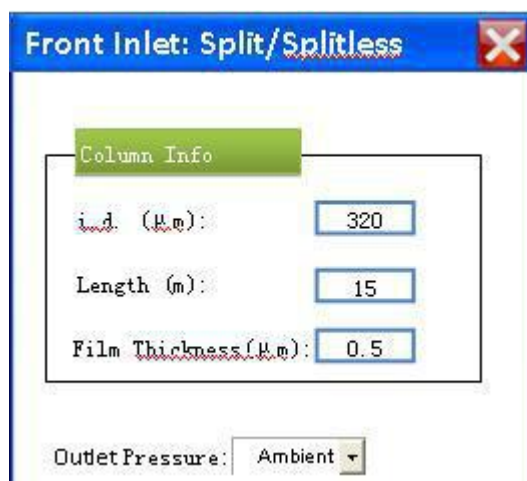

**Note:** Flow pressure and other parameters need to be reissued after changing column parameters

3. Mode: Split

Carrier gas: Nitrogen

Control mode: Constant flow

Column flow: 2ml/min

Split ratio: 20:1

Injection temperature: 250°C

Param	Actual	Setpoint	Unit
Total Flow	[redacted]	[redacted]	mL/min
Split Ratio		20:1	N:1
Purge	[redacted]		mL/min
Flow	[redacted]	2.0	mL/min
Pressure	[redacted]		psi

4. Switch on the carrier gas, open injection and start heating when column flow reaches set value, total flow and column head pressure becomes stable.

5. Switch off Injection interface and return to the main interface.

6. Press  on the main interface, enter the detector setting interface.

7. Hydrogen: 20

Air: 200

Make up gas: 20

Measuring range:  $10^9$

Temp (°C):	35.21	220.0	ON
H <sub>2</sub> (mL/min):	19.99	20.0	ON
Air (mL/min):	200.00	200.0	ON
Makeup (mL/min):	20.00	20.0	ON

Range:  10<sup>7</sup>  10<sup>8</sup>  10<sup>9</sup>  10<sup>10</sup>

Polarity:  Off  On

Flame :

8. Switch on the detector and start heating

9. Close detector interface and return to main interface

10. Enter column oven interface

Set column temperature: 150

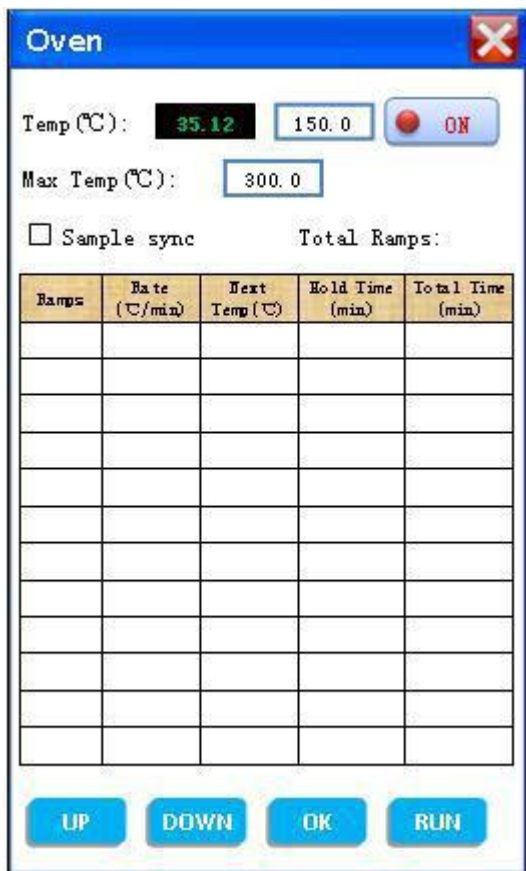

11. Switch on the column oven temperature switch and start heating

12. Close column oven interface and return to main interface. Enter detector interface again. If the temperature of the detector is stable, open the switch of the hydrogen and air. When the flow reaches the set value, fire up. The sample analysis can be started if the baseline becomes stable.

### 2.2.2.2 Program temperature rise analysis

Main machine temperature control realization needs column oven, injection and detector temperature control parameters be set. When injection, detector reaches set temperature, column oven reaches set initial temperature, the detector outputs stable signal, then the sample can be injected to analysis. Press “start” of computer temperature control and “sampling” of the workstation while sampling. The column oven will start program temperature rise and workstation will do quantitative calculation.

Program temperature rise process can be saw through the LCD of the main machine or the interface of column oven. When it reaches last stage, or the

“stop” is pressed, the backdoor of the column oven will open immediately and start cooling.

Cooling from maximum temperature to set initial temperature needs a few minutes. During this time, the backdoor will keep open, and even if the temperature reaches initial temperature, the backdoor will close after a few minutes. Because it takes time for the internal temperature to get balanced and stable, or the temperature will fluctuate greatly. So from the first analysis to the second time program temperature rise, you need to wait for more than ten minutes.

The FID standard sample test will be used as an example to illustrate the method of parameter setting.

Test condition: SE30 15m×0.32mm×0.5µm capillary column

Column initial temperature: 100°C; Detector: 220°C; Injection: 250°C;

Column flow: 2ml/min; Split ratio: 20: 1;

Hydrogen: 20 ml/min; Air: 200 ml/min; Make up gas: 20 ml/min;

Program temperature rise:

Initial time: 10 min;

1 stage speed: 4°C/min;

1 stage temperature: 160°C;

1 stage retention time: 5min;

2 stages speed: 2°C/min;

2 stages temperature: 180°C;

2 stages retention time: 15min;

3 stages speed: 2.5°C/min;

3 stages temperature: 200°C;

3 stages retention time: 22min.

Procedure:

1. The first 8 steps are same as 1-8 steps of the constant temperature analysis.  
 .....

9. Enter column oven interface.

Column temperature: 100

Initial retention: 10

1 stage speed: 4

1 stage temperature: 160

1 stage retention time: 5

2 stages speed: 2

2 stages temperature: 180

2 stages retention time: 15

3 stages speed: 2.5

3 stages temperature: 200

3 stages retention time: 22

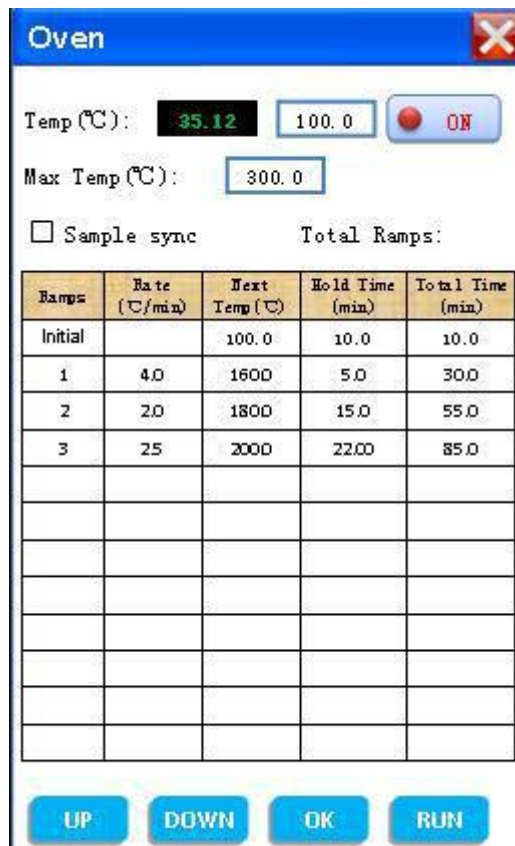

- 10. Open column oven temperature switch and start heating
- 11. Close column oven interface, return to the main interface. Then enter the detector interface. Open the hydrogen and air switch when the temperature of the detector is stable. After the flow reaches the set value, light the fire.
- 12. Back to the main interface, when the start button becomes bright, sample analysis can be started.
- 13. Press the start button after injection, the program will start up, and if the sampling synchronization is enabled, the data will be collected synchronously

## 3. Instrument installation and operation

### 3.1 Power requirements

- ◆ Voltage:  $220V \pm 22V$ ;
- ◆ Frequency:  $50\text{Hz} \pm 0.5\text{Hz}$
- ◆ Power: 2000W
- ◆ The power socket is suggested to be used separately
- ◆ Single-phase industrial frequency AC, single power supply. If the power exceeds  $220V \pm 22V$ , or the interference is serious, it is suggested to prepare a 3000 watt AC electronic voltage stabilizer.

**Note:** Except live line and neutral line, the power should have an individual earth line. Earth line and neutral line cannot use the same line.

## 3.2 Preparation and treatment of gas source

### 3.2.1 Gas source

Commonly used gas types for gas chromatograph: nitrogen, hydrogen, helium, argon and air. The air source of GC1290 can be cylinder gas or gas generator, as to air, oil-free air compressor can be used.

The gas pressure, purity should meet following requirements

Gas type	Instrument inlet pressure	Purity
Nitrogen/ helium/ argon	0.4 MPa	99.999%
Hydrogen	0.3 MPa	99.999%
Air	0.4 MPa	Oil-free, dry, Pollution free gas

### 3.2.2 Gas source treatment

The gas must undergo a rigorous purification before entering the instrument. A universal purifier is attached to the instrument. The purifier consists of purification tube and switch valve, which is connected between the air source and instrument. The activated allochroic silica gel or molecular sieve is added to the purification tube to absorb moisture or hydrocarbon impurities in the gas. The supply and cutting of the gas can be controlled by the switch valve knob.

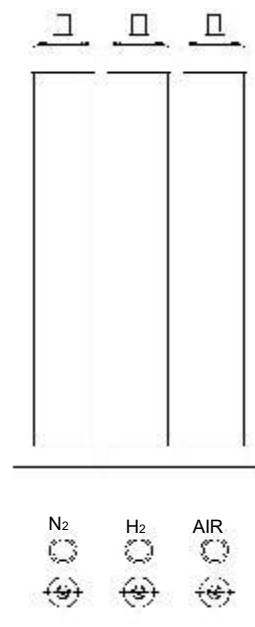



### 3.3 Connection of external gas circuit

#### 3.3.1 Connect gas inlet tube to the gas path connectors

External gas tube of GC1290 gas chromatograph is  $\phi 3 \times 0.5$  polyethylene tube or  $\phi 3 \times 0.5$  stainless steel tube (copper tube). Nut cap is M8 $\times$ 1,  $\phi 3.2$ .  $\phi 3 \times 0.5$  polyethylene pipe uses sealing liner tube. Using sealing liner tube can enhance the strength of the tube at the sealing point so that ventilation and sealing performance can be ensured. If  $\phi 3 \times 0.5$  stainless steel connection tube is used, the  $\phi 2 \times 0.5 \times 20$  sealing liner tube becomes not necessary. O shape sealing ring can also be replaced by 5mm  $\phi 5 \times 1$  PTFE tube. 2 O shape sealing ring should be used at the same time, or the sealing performance might not be ideal. Maximum sealing pressure is 0.5MPa $\sim$ 0.8MPa

(5kgf/cm<sup>2</sup> $\sim$ 8kgf/cm<sup>2</sup>) . Do not use common soap water with stronger alkalinity to check whether gas connection part leaks, or it will corrode the spare parts. The dilute solution of Sodium Lauryl Sulphate is a good choice for check.

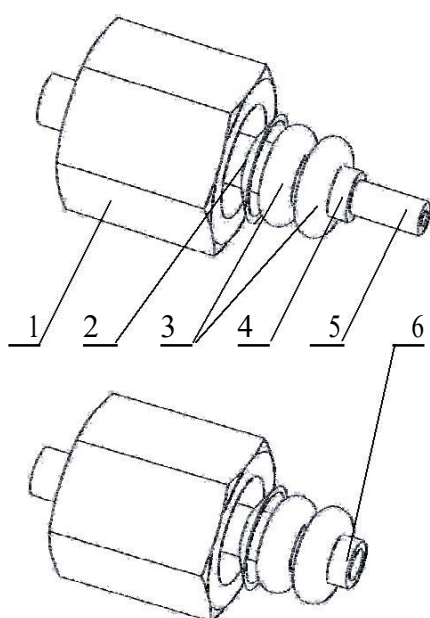

1. Nut cap(M8 $\times$ 1,  $\phi 3.2$ )
2. Sealing liner ring (phosphor copper)
3. O shape sealing ring (2.8\*1.8)\*2
4.  $\phi 3 \times 0.5$  polyethylene tube
5. Sealing liner tube( $\phi 2 \times 0.5 \times 20$  stainless steel tube)
6.  $\phi 3 \times 0.5$  stainless steel tube (copper tube)

**Note:** If the user wants to use  $\phi 3 \times 0.5$  stainless steel tube (copper tube) as gas inlet tube, the user needs to order it separately.

### 3.3.2 The installation of pressure reducing valve

If the cylinder gas is used as an external gas source, the pressure reducing valve should be installed at the outlet of the carrier gas, hydrogen and air cylinder.

The procedure is as follows:

- (1) Unscrew two oxygen pressure reducing valves and the low-pressure outlet head of the hydrogen pressure relief valve, then connect the pressure relief valve joint (**Note:** The whorl of hydrogen pressure reducing valve is reversed), Rotate low pressure output regulating lever. (Do not over tighten)
- (2) Install the pressure-reducing valve on the cylinder. (**Note:** The plastic ring in the packing box of the pressure reducing valve should be installed on the cylinder joint of the valve.) After tightening the nut cap, open the cylinder high pressure valve, the high pressure indicator of the pressure reducing valve should have some instructions. After switching off the high pressure valve, the pressure should not drop, otherwise there might be a leak, which needs to be ruled out.

#### **Note**

If the user intends to use cylinder as gas source, pressure reducing valve should be purchased separately. Hydrogen reducing valve needs 1.

Oxygen reducing valve needs 2.

If generator is used as gas source (nitrogen, hydrogen generator and air pump), the pressure reducing valve is not necessary. As to installation of generator, please refer to the instruction enclosed. The air pump must be oil free, otherwise it will pollute the gas path of the chromatograph.

### 3.3.3 External gas path connection

Cut the  $\phi 3 \times 0.5$  PE tube into 7 segments, then connect it between pressure reducing valve joint (or gas generator outlet) and purifier inlet (joint on the switch valve), purifier outlet (joint on the drying cylinder) and gas path inlet of main machine according to the method described in section 3.3.1.

**Plus:** The carrier gas path needs to be divided into 2 paths to connect carrier gas inlet of injection module and tail blowing inlet of detection module.

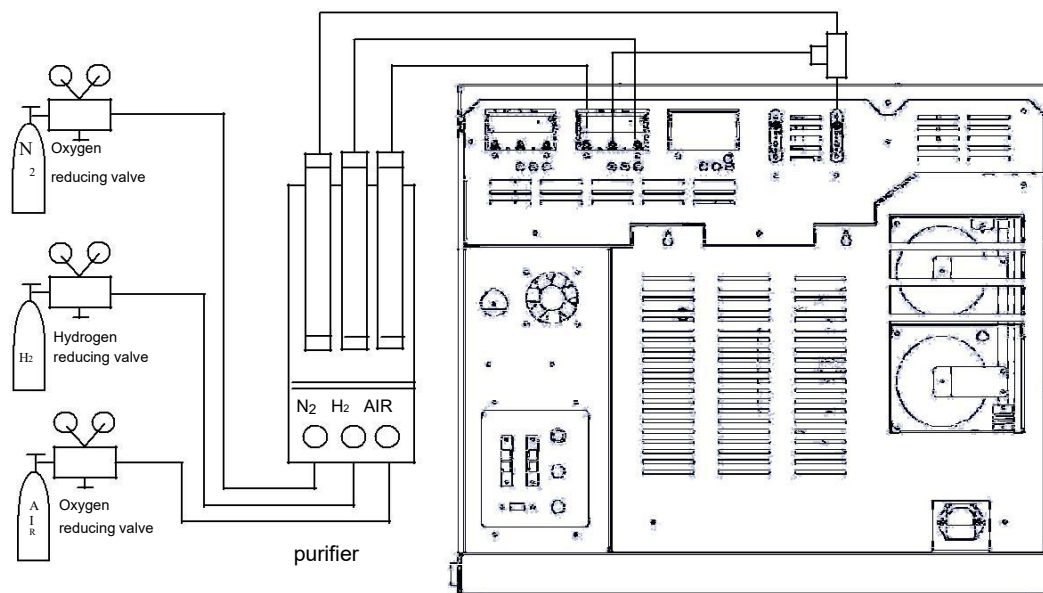

1. When the machine is off, open the cylinder high pressure valve (low pressure lever must be relaxed when opening cylinder high pressure valve). Rotate low pressure regulating lever until low pressure gauge indicates  $4\text{kg/cm}^2$
2. When close high pressure valve of each cylinder low pressure indication value on pressure reducing valve should not decrease. Otherwise it means there is air leakage in the external gas path.

Use gas generator to detect the leak:

1. When the machine is off, turn on the gas generator.
2. When the generator is under operation, the flow should display 0. If it is not 0, the air leakage might exist in external gas path. (This method is only suitable for the gas generator with flow display function)

### 3.4 Installation of packed columns

As to column head injection, the inlet part of  $\phi 5$ -6mm packed column should set aside free column (at least 50mm). So that injection needle can be inserted into gasifier when sampling. But it is not required for  $\phi 3$ -4mm packed column.

Because  $\phi 3$ -4mm packed column uses special transition joints.

Due to the steel properties of the column, the  $\phi 5.7$ mm packed glass column must be installed at the injection inlet and detector inlet simultaneously.

#### 3.4.1 Install $\phi 3$ mm and $\phi 4$ mm metal column on packed column inlet

1. Place nut cap (6), graphite sealing washer (5) and packed column transition joint(2) on the packed column sequentially.
2. Put column head in the transition joint hole (As shown in Figure), hold the position and tighten the nut cap by hand. Then use two suitable wrenches, one on the nut and the other on the transition joint, tighten it reversely and seal.
3. Put nut caps (M12 $\times$ 1,  $\phi$  5.2) and graphite furnace sealing washer ( $\phi$  5) on the transition joint in turn.

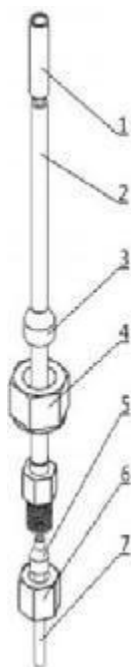

Num.	Name	Specification	
1	Casing (column head sampling)	$\phi 5$ mm	$\phi 5$ mm
2	Transition joint(sampling)	$\phi 3$ mm	$\phi 4$ mm
3	Graphite washer	$\phi 5$ mm	$\phi 5$ mm
4	Nut cap	M12 $\times$ 1, $\phi$ 5.2m m	M12 $\times$ 1, $\phi$ 5.2m m
5	Graphite washer	$\phi 3$ mm	$\phi 4$ mm
6	Nut cap	M8 $\times$ 1, $\phi$ 3.2mm	M8 $\times$ 1, $\phi$ 4.2mm
7	Metal column	$\phi 3$ mm (OD)	$\phi 4$ mm (OD)

4. Put the casing (1) on the transition joint, then push transition joint and casing into the outlet connector of the sampler, and insert them as deep as possible
5. Hold this position, tighten the nut cap (M12×1, φ5.2) with the outlet connector of the sampler by hand. Then tighten and seal it with wrench No. 17.

### 3.4.2 Install φ5mm metal column on packed column inlet

1. Place nut cap (3), graphite sealing washer (2) and casing (1) into packed column sequentially. (Transition joint is not required.)
2. Insert the column into the sample outlet as deep as possible.
3. Hold this position, tighten the nut cap and injector outlet connection by hand. Then tighten and seal it with wrench No. 17.



Num.	Name	Specification
1	Casing (column head sampling)	φ5
2	Graphite sealing washer	φ5
3	Nut cap	M12×1, φ5.2
4	Packed column	φ5 metal column

### 3.4.3 Install φ6mm metal column and φ5.7mm glass column to packed column inlet

1. Place nut cap (3), graphite sealing washer (2) directly into the packed column sequentially. (Transition joint is not required.)
2. Insert the column into the sample outlet as deep as possible.

3. Hold this position, screw nut cap and injector outlet connection by hand.  
Then tighten and seal it with wrench No. 17.



Num.	Name	Specification	
1	packed column	φ6 metal column	φ5.7 glass column
2	Graphite washer	φ6	φ6
3	Nut cap	M12×1, φ6.2	M12×1, φ6.2

### Note

When installing the glass column, do not push too hard, or the column might be broken.

### 3.4.4 Install φ3 and φ4mm metal column on FID detector

1. Place nut cap (5), graphite sealing washer (4) and packed column transition joint (1) into the other side of the packed column sequentially. (The column head of this side is filled with fillers.)
2. Make the column head out of the transition joint about 1~2mm, hold the position and tighten the nut cap by hand, then use two suitable wrenches, one on the nut and the other on the transition joint, tighten and seal them.

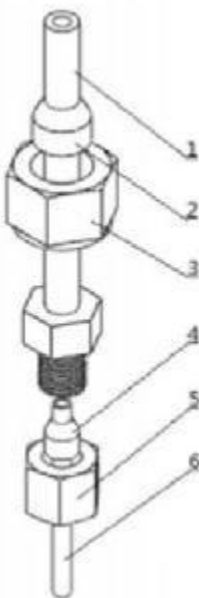

Num	Name	Specification	
1	Transition joint (Detect)	φ3mm	φ4mm
2	Graphite washer	φ6mm	φ6mm
3	Nut cap	M12×1, φ6.2mm	M12×1, φ6.2mm
4	Graphite washer	φ3mm	φ4mm
5	Nut cap	M8×1, φ3.2mm	M8×1, φ4.2mm
6	Metal column	φ3mm (OD)	φ4mm (OD)

3. Place nut cap (M12×1, φ6.2) and φ6 graphite sealing washer into the transition joint.
4. Push the transition joint and column head into FID inlet until touching the root part.
5. Hold this position, tighten the nut caps (M12×1, φ6.2) on the FID inlet by hand, then tighten and seal them with wrench No. 17.

### 3.4.5 Install φ5mm, φ6mm metal column and φ5.7mm glass column on FID detector

1. Place nut cap (3) and graphite sealing washer (2) directly into the other side of the packed column sequentially. (The transition joint is not required.)
2. Push the column head into FID inlet until touching the root part.
3. Maintain this position, tighten the nut cap (M12×1, φ 6.2) to the FID inlet connector, then tighten and seal them with wrench No. 17.



Nu m.	Name	Specification		
		φ5 metal column	φ6 metal column	φ5.7 glass column
1	Packed column	φ5 metal column	φ6 metal column	φ5.7 glass column
2	Graphite washer	φ5	φ6	φ6
3	Nut cap	M12×1, φ5.2	M12×1, φ6.2	M12×1, φ6.2

#### Note

After installation of the column, all the joints and nut caps should get leakage check at room temperature, operation temperature of column oven, injection and detector. If necessary, tighten with wrench to prevent leakage.

### 3.5 Install capillary column

The capillary column can be installed after installation of the split quartz tube, capillary injector and tail blowing joint parts. GC1290 instrument capillary analysis system adapts to all kinds of capillary column. Such as: soft quartz capillary column (Molten silicon capillary column). OD 0.375mm~0.45mm soft quartz capillary column, large caliber capillary column (ID: 0.53mm, 0.75mm and so on). Different capillary column should use capillary sealing washer with different specifications.

Column type (OD)	Capillary seal washer
Large caliber capillary column (0.53~φ0.75mm)	Graphite sealing washer (ID: φ0.9mm)
Soft quartz capillary column (φ 0.375 ~ φ0.45mm)	Graphite sealing washer (ID: φ0.35mm)
Note: Generally the OD of ID 0.05mm~0.25mm capillary column is 0.375mm; The OD of ID 0.32mm capillary column is 0.45mm; The OD of ID 0.53mm capillary column is 0.69mm.	

Installation of capillary column:

1. Install capillary column tail blowing connector part on the lower end of the detector.
2. Insert both ends of capillary column installation frame into ovaloid hole in the column oven. (There are 2 groups (4) ovaloid holes in the column oven. The user can choose one group). Then hang the frame which is wrapped with capillary column on the capillary column installation frame.
3. Insert M6 column screw, capillary sealing washer into one end of the capillary column inlet.
4. Push one end into capillary column inlet, capillary column head must exceed split point (about 4-6mm). Hold this position and tighten the nut with a wrench.

**(Note: Overtightening may break the capillary column)**



5. Put M5  $\phi$ 1.6 nut cap, capillary sealing washer into one end of the capillary column outlet.
6. Push tail blowing joint which is installed at the FID inlet with the other side of the column, column head should touch the bottom of the spout. Hold this position and tighten the nut cap with a wrench.

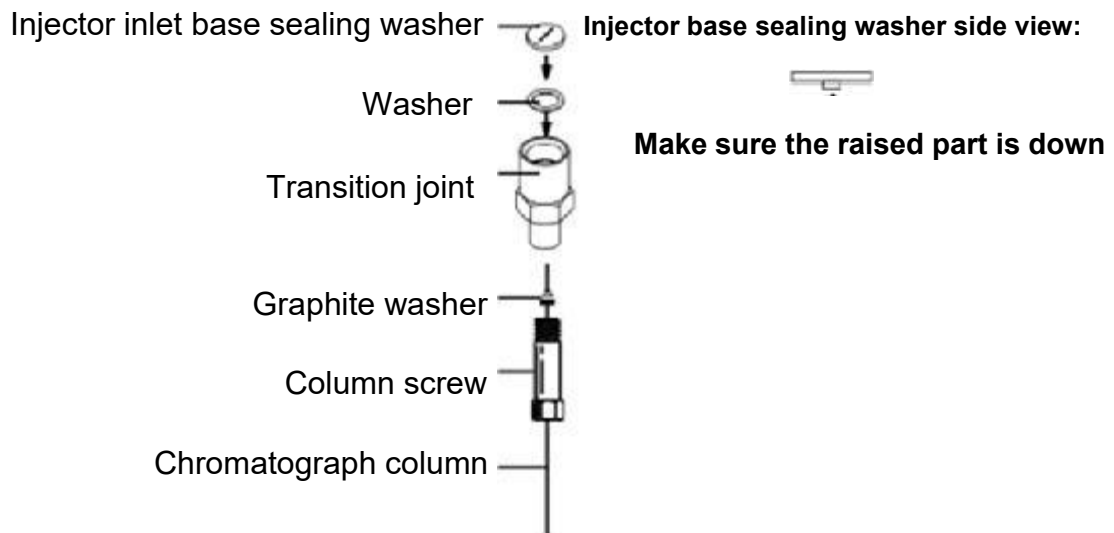
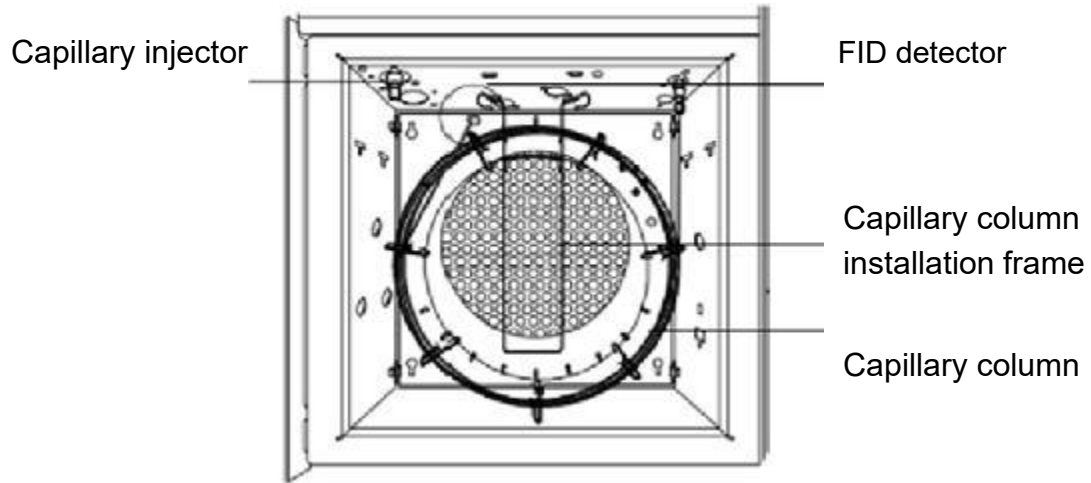

Installation of tail blowing joint components:

1. Insert  $\phi 6$  graphite washer (2) into tail blowing quartz tube (1)
2. Put tail blowing quartz tube into the tail blowing joint component (3)
3. Insert tail blowing joint component into FID detector inlet and tighten it by hand
4. Tighten and seal it with wrench No. 17

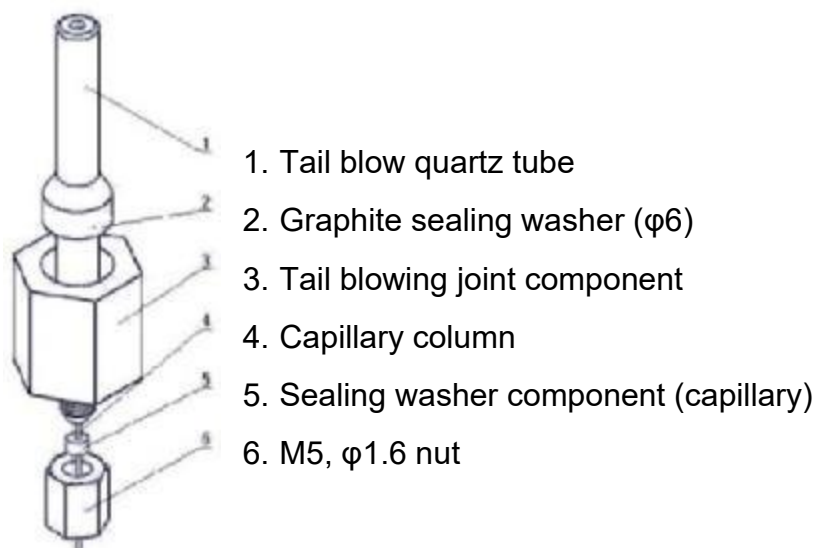

### 3.6 Connect chromatograph software

GC1290 can be connected directly to the computer through USB connection line, FID amplifier signal can be outputted by software. Detail direction please refer to software instruction.

## 4. Detector system

GC1290 can install Flame Ionization Detector (FID), Thermal Conductivity Detector (TCD), Electron Capture Detector (ECD), Flame Photometric Detector (FPD), Nitrogen Phosphorus Detector and Quadrupole Mass Spectrometer (QMS). This chapter will introduce the installation of FID.

### 4.1 FID

#### 4.1.1 Working principle

The energy of FID comes from the combustion of hydrogen and air. Carbonaceous organics become  $\text{CH}\cdot$ ,  $\text{CH}_2\cdot$ , then react with oxygen and become  $\text{CHO}^+$ ,  $\text{CH}_2\text{OH}^+$ ,  $\text{COOH}^+$ ,  $\text{COO}^+$ ,  $\text{CHO}_2$ . The vapor in the flame collides with  $\text{CHO}^+$ , forming  $\text{H}_3\text{O}^+$ .

Taking benzene as an example, the chemical ionization process is as follows:

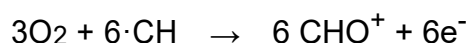
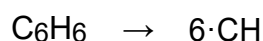

By the effect of electric field, the positive ions  $\text{CHO}^+$ ,  $\text{H}_3\text{O}^+$  and electron  $\text{e}^-$  respectively move to the collector and emitter, forming ion current. Measurable chromatographic signal can be obtained after the amplification of the ion current (flowing through the amplifier). Since the produced ion flow is proportional to the substance entering the flame, this principle can be used in quantitative analysis of the organic substance.

#### 4.1.2 Structure of flame ionization detector

The flame ionization detector (FID) of GC1290 gas chromatograph is a barrel shape detector.

FID structure:

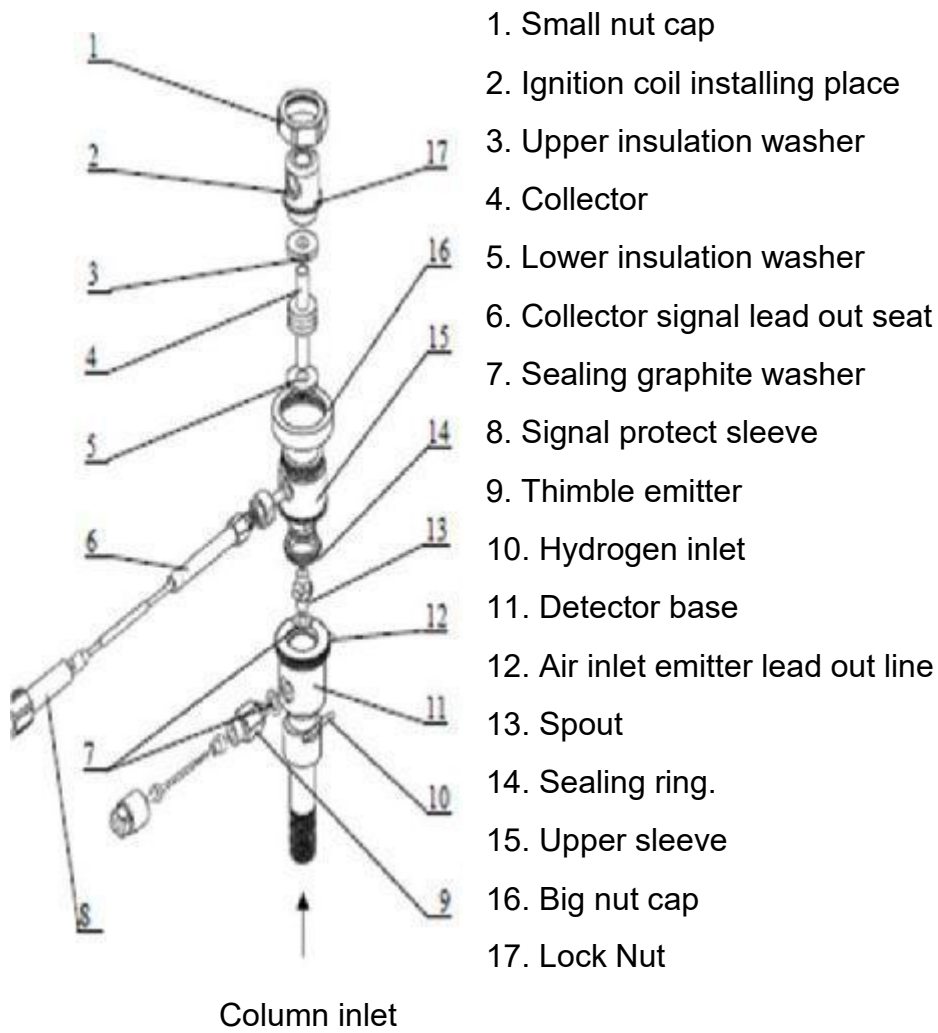

Spout structure:

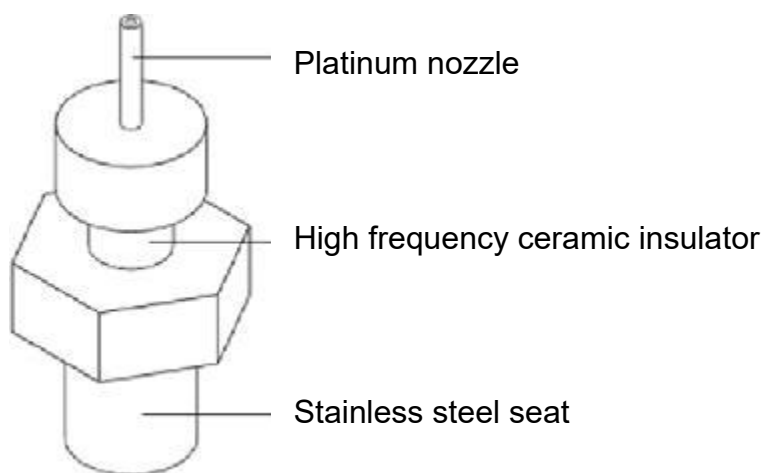

### Note

Inner diameter of GC1290 FID nozzle is about  $\phi$  0.4mm, suitable for packed column and capillary column analysis. If the user needs capillary column analysis FID nozzle (the inner diameter of the nozzle is about  $\phi$  0.3mm), please contact our company.

If users find the nozzle blockage and pollution during using, clean the nozzle in time, replace it with a new sealing graphite washer and tighten the nozzle with a sleeve, make sure no gap between nozzle and FID base.

#### 4.1.3 Flame ionization detector optimal flow volume

FID is a mass detector, and its sensitivity is not only affected by the structure of detector, but also depends on the velocity of hydrogen, air and nitrogen.

Usually "hydrogen: air ratio = 1:10" can achieve higher sensitivity.

Recommended flow setting:

##### 1. Carrier gas (usually nitrogen) flow

When connecting the packed column, set it 20mL/min~60mL/min, then adjust it according to analysis requirements.

When connecting the capillary column, the carrier gas flow should be set according to the inner diameter of the chromatographic column. Split flow should be set according to the split ratio.

##### 2. Hydrogen: 20mL/min~30mL/min

##### 3. Air: 200mL/min ~ 300mL/min.

##### 4. Tail blowing: 20 mL/min ~30 mL/min

## 4.2 Connection of FID and main machine

The GC1290 single detector is placed at the top front of the main machine, and its base is in an aluminum heat conductor. The heat conductor is also equipped with the electric heating element and ceramic platinum resistor, which are connected with the main wiring board in the microcomputer temperature controller. The collector signal outlet line is connected with the signal entrance on the shielding box of the FID micro current amplifier through the high frequency cable. The emitter outgoing line is transferred to the input terminal of the high voltage module through a line-to-line plug at the back of the main engine. (-250V). The outlet line of the igniter is connected to the ignition socket on the FID micro current amplifier plate. The outlet of the chromatography column is placed at the entrance of the FID detector at the top of the column oven and sealed with nut and graphite gasket. The hydrogen and air are connected to the outlet of the FID gas path module by the stainless steel pipe.

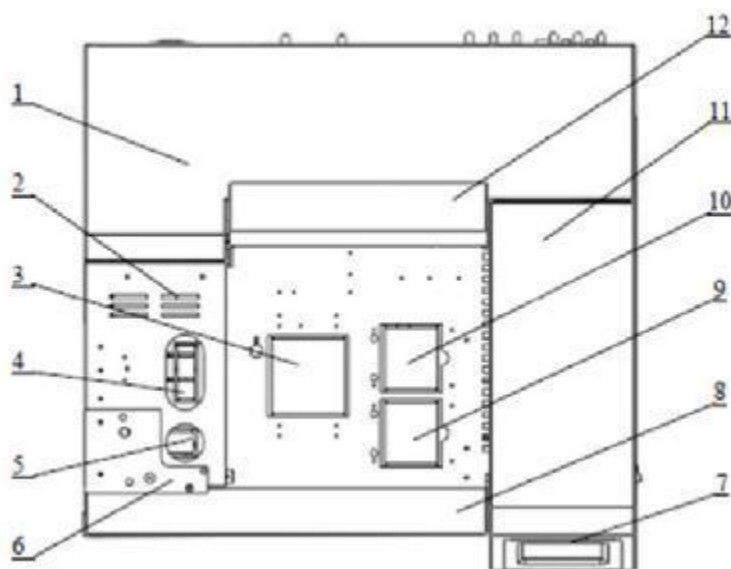

- |                                 |                                   |
|---------------------------------|-----------------------------------|
| 1. Rear cover                   | 2. Sampling cover                 |
| 3. TCD installation             | 4. Back sampler installation      |
| 5. Forward sampler installation | 6. Automatic sampler installation |
| 7. LCD touch screen             | 8. Heat insulating board          |
| 9. Front detector installation  | 10. Rear detector installation    |
| 11. Right cover                 | 12. Cover of the column oven      |

### 4.3 FID micro current amplifier

FID micro current amplifier of the GC1290 uses the working principle of current --- voltage conversion. Convert the micro current obtained by the FID detector collector (transmitted by high frequency cable) into impedance and then send it to a recorder or data processing device.

The range, polarity setting and selection of GC1290 FID amplifier can be completed on LCD touch screen. (Please refer to chapter 2 ---detector operation)

### 4.4 FID constant temperature analysis operation

When the installation is completed, the operation and analysis of the instrument can be carried out. The operation steps of FID detector at constant temperature are as follows: (Take capillary column as an example)

1. Connect outside gas path of the carrier gas, air and hydrogen, and detect the leak.
2. Install the aged column (from injector to FID detector).
3. Open the nitrogen cylinder valve and rotate the low pressure adjusting lever until the carrier gas low pressure meter indicates 3.5Kg/cm<sup>2</sup>~6Kg/cm<sup>2</sup> (If the nitrogen generator is selected, the operation shall be carried out according to its instructions)
4. Open the main machine power supply, set column oven, detector 1 and injector 1 temperature respectively according to the second chapter, and other parameters such as carrier gas column flow, pre column pressure, split ratio, control mode and so on

For example:

Column oven: 150°C      Injector 1: 250°C      Detector 1: 230°C

Column flow: 2ml/min      Split ratio: 20/1

5. As to connection of data processor or the signal wire components of the chromatography workstation, please refer to the preceding section. Open the data processor or chromatography workstation power supply, and record the

baseline.

6. Set the FID amplifier in the required operating state.

For example:

Sensitivity (range):109;           polarity: "OFF" (output set to "+").

7. When the injector, detector (FID) and column oven's temperature become balanceable, the flow pressure becomes stable, open the cylinder valve of air and hydrogen and rotate the low pressure regulating lever until air low pressure meter indicates 3Kg/cm<sup>2</sup>~6Kg/cm<sup>2</sup> (If the hydrogen generator and air pump are selected, the operation shall be carried out according to their instructions).

8. According to the operating conditions, the air, hydrogen flow and tail blowing flow should be set up and opened.

For example:

Air: 200 ml/min Hydrogen: 20 ml/min Tail blowing flow: 20 ml/min

9. Ignition (Please refer to chapter 2). When the flame is ignited, the baseline will deviate from the original position.

There are two ways to judge whether the fire is ignited or not:

1) Change the hydrogen flow rate. If the baseline changes, the fire has been ignited.

2) Place metal or glass plate with smooth surface at the "vent" of the ion chamber.

If there is water vapor condensation on the surface of the metal or glass, the fire has been ignited.

10. Use the "coarse" and "fine" base flow compensation button on the FID interface to adjust the baseline to the appropriate position. When it is stable, the analysis can be started.

#### 4.5 FID temperature programming analysis operation

1. Same as 1-10 steps of last section

2. Set the parameters of the required temperature programming curve according to the method described in the second chapter.

3. When the baseline is stable, observe the actual temperature display values



of the controlled objects on the temperature control panel. When all is constant at the set value, the sample can be injected.

4. Press the "start" button at the same time, then the temperature programming is started. When the column oven cools down, the total temperature programming analysis is completed.

### **Notes**

1. After the sampling, if the peak direction is reversed, press the "polarity" on the FID interface. The polarity switching can change the peak direction.
2. If the user uses a data processor or chromatography workstation, the positive and negative polarity of the signal can be changed by the "polarity" on the temperature control panel (Please refer to chapter 2). You can also change the connection position of the positive and negative lead wires of the signal to change it.
3. The sensitivity of FID depends on the flow rate ratio of H<sub>2</sub> to carrier gas (or to capillary column carrier gas + tail blowing). Generally, increasing air flow rate may be necessary if the concentration of sample components is high. On the contrary, reduce the air flow velocity.

### **4.6 FID detector using precaution**

1. The detector is a highly sensitive detector, and high purity carrier gas (99.99%N<sub>2</sub>) must be used, and carrier gas, hydrogen and air should be purified by the purifier.
2. When the column is aged, do not connect the column to the detector in case that the detector is contaminated. The highest using temperature of the attached column is 280°C. Do not open the source of hydrogen when aging columns.
3. Close the hydrogen and air source before the operating temperature is balanced so as to prevent water accumulation in the detector.
4. When igniting, do not press the button too long, or might damage the ignition ring.
5. The column used should be thoroughly aged when the instrument is used for

maximum sensitivity use or temperature programmed analysis.

6. When the instrument is switched on, first introduce carrier gas and rise the temperature. Ignite only when FID detector temperature reaches the set temperature.

7. If the detector temperature is too low, there might be water in the detector after ignition. So the FID detector set temperature must be more than 150 degrees, in order to avoid water left inside the detector.

8. When the GC1290 FID is ignited, the hydrogen will automatically increase to 50 ml/min. If still unable to ignite, it is recommended to increase the hydrogen flow, and ignite again. Transfer the flow of hydrogen back to the required flow value after the ignition.

9. First turn off the hydrogen (fire extinguishing), then cool down, and then close the carrier gas.

#### **Note**

Flame ionization detector uses H<sub>2</sub> as gas. If the H<sub>2</sub> is opened, and the column is not connected to the detector inlet connector, H<sub>2</sub> will flow into heating chamber and cause explosion. Therefore, once hydrogen is connected to the instrument, the column should be put between the injector and the inlet of FID, or screw M12×1 bulkhead nut with φ10×5 gasket (silicone rubber) into the FID inlet, and then tighten and seal with a wrench.

## 5. Injector system

There are two kinds of injector can be chosen for GC1290: packed column injector and split / splitless capillary injector. The collocation can be done as follows: double packed column injector, double packed column + single capillary column injector, double capillary column injector. Users can choose according to the need.

### 5.1 Packed column injector

Single/ double packed column injector is installed in the heat conductor which is at the left side of the main machine. The electric heating element (80W) and ceramic platinum resistor are also installed in the heat conductor. The microcomputer temperature controller controls its temperature. The installation steps of the packed column are in Chapter 3.4

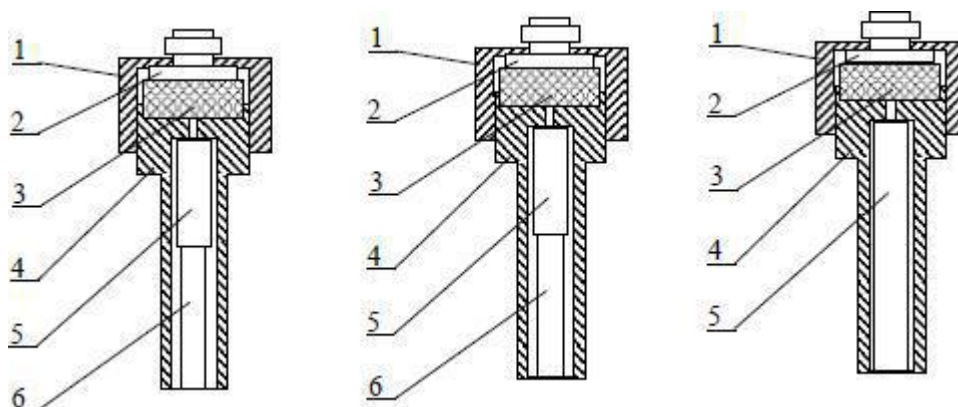

φ 3mm, φ4mm

1. Radiator
2. Guide port
3. Silicone rubber gasket
4. Injector
5. Drivepipe
6. Transition joint (injection)φ3  
Transition joint (injection)φ4

Φ5mm

1. Radiator
2. Guide port
3. Silicone rubber gasket
4. Injector
5. Drivepipe
6. Packed column (φ5)

Φ6mm

1. Radiator
2. Guide port
3. Silicone rubber gasket
4. Injector
5. Drivepipe
6. Packed column (φ5)

The instrument is equipped with 3mm stainless steel packed column. In addition, the φ4mm, φ5mm, φ6mm stainless steel packed column and φ5.7mm glass packed column can also be installed in packed column sampler.

## 5.2 Capillary injector

The capillary column sampling system of GC1290 can realize capillary column diffidence, split/ splitless, and splitless modes, and can realize 4 kinds of control modes: Constant flow, constant pressure, gradient flow and gradient pressure. Capillary injector structure:

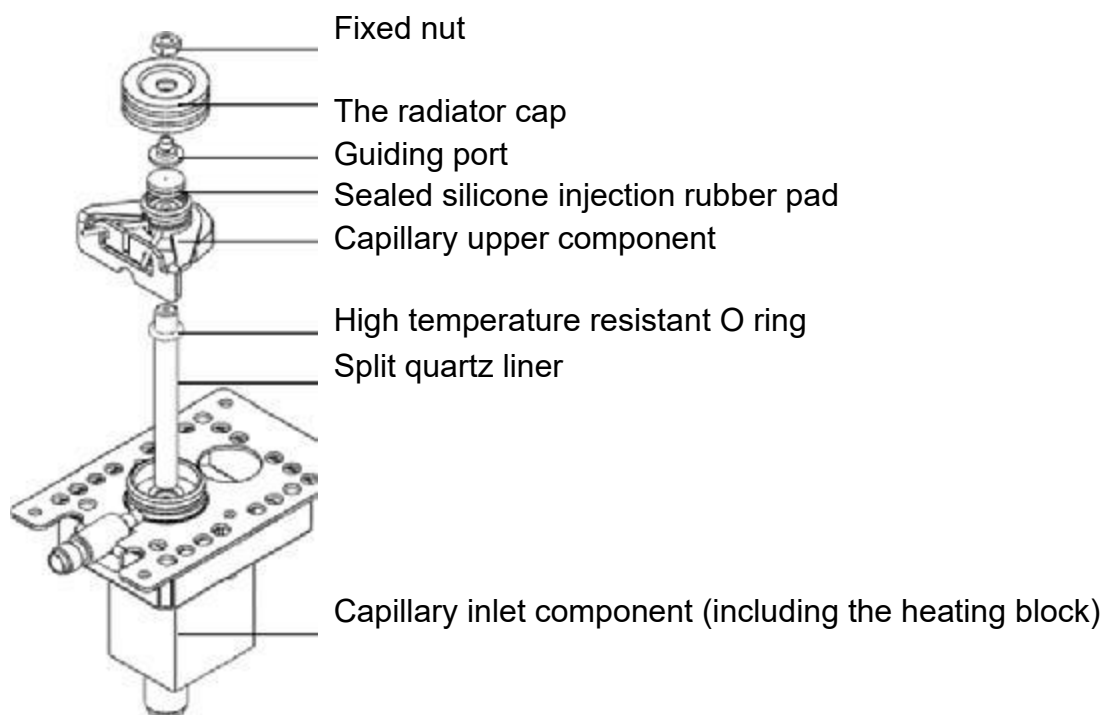

Gas circuit module:

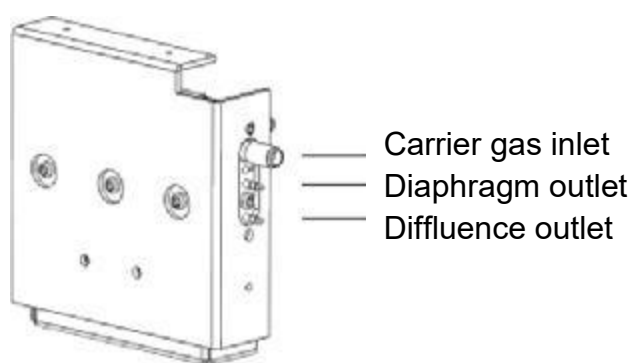

### 5.3 Introduction of capillary flow

Capillary column diffidence mode: The sample injected into the inlet is only partially imported into the capillary column, the remaining samples were discharged through a shunt flow path in the split flow module.

Split/ splitless mode: The split port closes when injecting, when the set time after injection passed, open the split port.

### 5.4 Installation of capillary injector

For the need of cleaning the capillary column injector and the internal shunt quartz liner. The installation steps of capillary injector are as bellow:

1. Unscrew the large nut of capillary upper component with a wrench.
2. After removing the distributary quartz liner from the injector, the cleaning operation can be carried out. Note: if the instrument is just closed, the temperature will be higher here, and be careful not to be scalded.
3. Put one end of a replaced or cleaned shunt quartz liner into a high temperature resistant O ring
4. Insert capillary column injector and push the shunt quartz liner into the bottom as far as possible.
5. Point the upper part into the sample seat and be careful not to break the shunt quartz liner
6. First, screw the big nut with hand, then tighten it with a wrench
7. Replace the sample pad: insert the silicone rubber gasket into the upper component, then put it into the heat cap, press and tighten it

#### **Note**

When conducting capillary analysis and using dangerous chemicals, the exhaust of the shunt outlet shall be discharged into the fume hood or corresponding chemical purifying pipe. After a long period of time. The adsorption tube (filter) which is installed in the flow control unit and the sampler should be took off, and replace new adsorbent, put a little glass cotton at two ends of the adsorption tube.

## 5.5 Precautions of capillary column analysis operation

Current capillary column analysis is a commonly used analysis method. The advantages are it is applicable to all kinds of samples, the concentration range is wider, good analysis of common type samples, higher column efficiency (because of the instantaneous sampling) The precautions are as follows:

1. Generally the diaphragm of this instrument does not need to be set. The system will adjust automatically according to current state. It is necessary to set only when injecting under split /splitless mode.
2. Measuring line velocity: Using the linear velocity of the column is to enter a component that is not retained by the stationary phase (Typical sample: CH<sub>4</sub>). Use stopwatch to determine the time from injection to the peak appearance (retention time). If using workstation, the retention time can be calculated automatically.

Calculation formula of line velocity:

Average line velocity:

$$\bar{\mu}(\text{cm/sec}) = \frac{\text{Column length } L(\text{m}) * 100}{\text{Retention time } t(\text{sec})}$$

3. Column volume flow velocity:

$$F_c = 15 \pi d^2 \bar{\mu}$$

$F_c$ : Column volume flow velocity, ml/min

$\bar{\mu}$ : Average linear velocity of carrier gas, cm/sec

$d$ : Inner diameter of capillary column, cm

Or take off the tail blowing joint component from FID, connect it with one end of soap-film flowmeter hose, directly measure the volume velocity of the post column through soap-film flowmeter. But tail blow flow must be closed when using this method.

4. The maximum shunt ratio can reach 1500:1. Shunt flow velocity can be measured by the soap-film flowmeter or electronic digital flowmeter connected at "split outlet". Please turn to 5.4-The use of soap-film flowmeter.

5. Measurement of shunt ratio: The shunt flow of conventional capillary column (0.22mm I.D. ~ 0.32mm I.D.) is generally 50:1-500:1. Large diameter thick liquid film capillary column is generally 5:1-500:1. 50 $\mu$ m~100 $\mu$ m small caliber

capillary column shunt ratio is beyond 1000:1.

Calculation formula of shunt ratio:

$$\text{Shunt ratio} = \frac{\text{Shunt low velocity}}{\text{Column volume velocity}}$$

Example 1: Column volume velocity is 1ml/min, shunt flow velocity is 200ml/min, then the shunt ratio is 200:1

Example 2: Column internal diameter is 0.31mm, average linear velocity  $\bar{\mu}$  = 13.2cm/sec, shunt flow velocity is 54ml/min, then the column volume flow velocity  $F_c = 15 \times 3.14 \times (3.1 \times 10^{-2})^2 \times 13.2 = 0.6 \text{ml/min}$

Shunt ratio =  $54/0.6 = 90:1$

## 5.6 The use of the soap film flowmeter

The soaping flowmeter can be used to determine the flow rate, such as shunt flow and post column flow (Tail blow joint outlet end or FID nozzle)

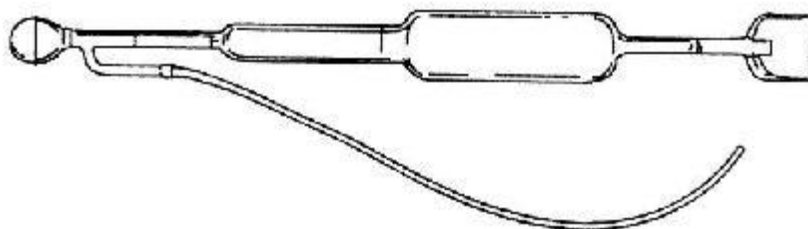

The soaping flowmeter has 3 velocity: 1, 10 and 100ml/min, suitable for low flow measurement (such as carrier gas) and high flow (such as the air of FID) The soaping flowmeter is the most basic and reliable tool for measuring the gas flow. When gas flows, the soaping flowmeter will create a bubble through and let it go through the tube. The move velocity of the bubble reflects the flow of gas. Most of soaping flowmeters have several sections. The gas flow of different ranges can be easily measured according to the diameter of each section.

The measurement steps are as below

1. Connect the end of the hose to the soaping flow meter

2. Connect the other end of the hose with the gas outlet at the measuring point
3. Inject soap liquid or leakage detection liquid into the ball of the soap flowmeter
4. Hold the soap film flowmeter vertically, pinch the ball below to produce a soapy bubble
5. When the soap film passes through the bottom line of the soaping flowmeter, start the stopwatch
6. When the soap film goes on the line of a certain range, stop the stopwatch.
7. Flow calculation unit: ml/min. If stop the stopwatch at the first range line, flow value is the displayed  $1/t$ . If stop the stopwatch at the second range line, flow value is 10 times higher than  $1/t$ . If stop the stopwatch at the third range line, flow value is 100 times higher than  $1/t$ .
8. Press [clear] button and repeat step 4 - 7 at least once to verify the correctness of flow.



## 6. Maintenance of the instrument

### 6.1 Maintenance of instrument

The correct maintenance of the instrument can not only make the instrument work properly, and can prolong the life of the instrument.

The following four points must be paid attention to during the maintenance

(A) The instrument should work strictly under the prescribed condition

(B) Work the instrument strictly in accordance with the operating rules. Oil pollution, organic and other matter is prohibited from detector and tube, in case of pipeline blockage or deterioration of instrument performance

(C) The column temperature should not exceed the allowable temperature of the fixed liquid in the stationary phase, generally the column temperature is under the allowable temperature of the fixed liquid. In high sensitive operation, the selection column temperature should be lower.

(D) GC1290 carrier gas inlet pressure is recommended at 343000Pa (3.5kg/cm<sup>2</sup>~6kg/cm<sup>2</sup>),

GC1290 air inlet pressure is recommended at 29400Pa~588000Pa (3kg/cm<sup>2</sup>~6kg/cm<sup>2</sup>)

GC1290 hydrogen inlet pressure is recommended at 196000Pa~343000Pa (2kg/cm<sup>2</sup>~3.5kg/cm<sup>2</sup>)

If use hydrogen as carrier gas, the carrier gas inlet pressure should be 343000Pa (3.5kg/cm<sup>2</sup>)

### 6.2 Cleaning of hydrogen flame ionization detector

Disconnect the upper cap of FID, take off ignition coil, collection pole and insulating washer. Use acetone or alcohol to clean the electrode and insulating ring, and drying them. If the pollution is serious, put the parts to be cleaned in ultrasonic cleaning solution. After ultrasonic cleaning, rinse with clean water, then wash with alcohol and dry them. When doing the assembly, ignition coil, collection pole signal elicitation pedestal and emitter elicitation line should not cut out with FID extensin and cannot touch the ground. If chromatographic

column fixed liquid polluted the detector, choose a solvent that can dissolve the fixed liquid to clean the fixed liquid.

Steps of unpacking the upper cap: Unscrew the big nut, take off the upper cap. Release the elicited seat of collecting pole signal with an open spanner and take it off. Unscrew the small nut on the cap with a wrench and take it off. Take out the collector and 2 insulating gaskets on the top and bottom. Unscrew the nut of the fixed ignition coil. ( The ignition lead out line is drawn out from it), and pull out the ignition coil

If you want to replace or remove the nozzle to clean, unscrew 4 M3 screws on the mounting plate with a screwdriver, take off the protective cover and the inner glass cotton, then unscrew and remove the emitter lead out line. Now there is no cover on the nozzle, unscrew the nozzle with 8mm socket.

#### **Note**

When the new nozzle is replaced, a new sealed graphite gasket must be replaced at the same time, and the nozzle is tightened with a socket in order to prevent air leakage.

### 6.3 Injector cleaning

The injector is easy to be polluted, especially the cannula and the transition joint (sampling), so the cleaning is very important.

The cleaning method of packed column injector:

Remove the column, unscrew the radiator, take out the sealed silicone rubber pads, cannula and guide ports, use acetone or alcohol to clean the radiator, guide port, cannula and transition joint (injection), then dry them. The internal wall of the injector tube can be repeatedly washed by acetone or alcohol cotton ball. After cleaning, blow with large flow carrying gas (mainly blow off cotton ball fiber and dry the solvent). Then install the cannula and column, put new sealed silicone rubber pad and guide port, then tighten the radiator.

The cleaning method of capillary column injector:

Unscrew the cooling cap, take down the guide mouth and seal silicone rubber pad, then unscrew the nut on the locating bush, take out shunt quartz liner and silicone rubber (graphite) seal gasket. Clean and dry the above parts with acetone or alcohol. After detaching the capillary column and the transition joint, clean the internal part of injection with the method of cleaning packed column injection. Then install the capillary column injection as 5.2.2

## 6.4 Chromatographic signal judgment and troubleshooting

Fault	Fault judgment	Inspection method and repair
1. No peak	(1) The amplifier is disconnected (2) Ion line is broken (3) No carrier gas flows through (4) Poor contact of acquisition board (5) Fault of acquisition board (6) The sampling temperature is too low and the sample is not vaporized (7) Microsyringe is blocked (8) The sample silicone rubber leaks (9) Column connection is released (10) No ignition (11) FID polarization voltage is not well connected	(1) Check amplifier, fuse (2) Check ion line (3) Check the airflow path, whether it is blocked, or the gas in the cylinder is used up (4) Check the wiring of the acquisition board (5) Eliminate the failure of the acquisition board according to instruction manual (6) Increase the temperature of the injector (7) Replace syringe (8) Replace silicone rubber (9) Tighten the chromatographic column (10) light the fire (11) Make sure the polarization voltage is well connected
2. Detention time is normal, while sensitivity declines	(1) Too much attenuation (2) Sample volume is not enough (3) Loss in sample process (4) Syringe leakage or block (5) Leakage of carrier gas, especially the leak of injector (6) Hydrogen and air flow are not selected properly(FID) (7) The detector has no high pressure(FID)	(1) Reduce attenuation and increase high resistance (2) Increase the amount of sampling (3) As far as possible, make the sample fully entered into the system (4) Change syringe or unchock the syringe (5) Detect the leak (6) Adjust hydrogen and air flow (7) Check or install high voltage

3. Tailing peak	<p>(1) The injection temperature is too low</p> <p>(2) Injection pipe pollution (Residue of samples or silicone rubber)</p> <p>(3) The column oven temperature is too low</p> <p>(4) Injection is not well done</p> <p>(5) The column was chosen improperly (The sample reacts with column carrier or stationary solution)</p>	<p>(1) Adjust the temperature of the injector</p> <p>(2) Clean the tube of the injector with solution</p> <p>(3) Increase the temperature of chromatography column</p> <p>(4) Improve injection method, inserting needle and withdrawing needle should be quick</p> <p>(5) Reselect appropriate column</p>
4. Leading peak	<p>(1) The column is overloaded, sample amount is too large</p> <p>(2) Sample agglutinates in the system</p>	<p>(1) Reduce sample amount</p> <p>(2) raise the temperature of the column first, then select the appropriate injector, column and detection temperature</p>
5. No detached peaks	<p>(1) The column temperature is too high</p> <p>(2) Column is too short</p> <p>(3) Loss of fixed liquid</p> <p>(4) Fixed fluid or carrier is not correct</p> <p>(5) The carrier gas flows too fast</p> <p>(6) Injection is not well done</p>	<p>(1) Lower column temperature</p> <p>(2) Select a longer column</p> <p>(3) Change column</p> <p>(4) Select appropriate column</p> <p>(5) Reduce gas flow rate</p> <p>(6) Improve injection method</p>
6. Circular top peak	<p>(1) Beyond detection linearity range</p> <p>(2) Too much attenuation</p>	<p>(1) Reduce sample amount</p> <p>(2) Readjust the attenuation</p>
7. Flat top peak	<p>(1) Amplifier input saturation</p>	<p>(1) Reduce sample amount, reduce the sensitivity of the amplifier</p>
8. Serrated baseline	<p>(1) Change of carrier- gas cylinder reducing valve output pressure</p>	<p>(1) Adjust the pressure of the pressure reducing valve</p>

9. No injection, but baseline changes(FID)	(1) The temperature of the detector is too low  (2) The column Temperature stops warming or out of control	(1) Increase the temperature of the detector over 100°C to clean the detector, or increase the temperature of the detector at 200 °C to eliminate the water vapor (2) Detect temperature control system and heating wire platinum resistance
10. Baseline mutation	(1) Plug is not well connected (2) External electric field interference (3) Improper selection of hydrogen and air flow (FID)	(1) Reconnect the plug  (2) Eliminate external electric field interference (3) Readjust hydrogen and air flow, especially air flow
11. Baseline drift	(1) Low sensitivity of acquisition board (2) Poor grounding of acquisition board	(1) Raise the sensitivity (2) Ensure the good grounding of the collection board and the whole machine
12. Detention time lengthens, sensitivity is low	(1) Gas carrying velocity is too slow  (2) Change of carrier gas flow after sampling (3) Sample silicone rubber leaks	(1) Increase the velocity of carrier gas. If there is a blocking in the airflow path, try to exclude it (2) Change sampling silicone rubber (3) Change sampler silicone rubber
13. Inverse peak	(1) The sample goes into another column (2) Position error of positive and negative switch	(1) Enter the sample into appropriate column (2) Put the positive and negative switches in the correct position
14. Irregular baseline fluctuations in constant temperature operation	(1) The instrument is not in good position  (2) Poor grounding of the instrument (3) The column fixed fluid loses  (4) The carrier gas leaks	(1) Put the instrument in the place without strong vibration and no strong air convection, position the instrument horizontally. It's better to put the instrument on a cement table or on a rubber table. (2) The instrument and recorder should be well grounded (3) Select the appropriate fixed fluid and fully age the column. The column temperature cannot be raised to the use limit of the fixed liquid.(especially high sensitivity detector) (4) Detect the leakage

	<p>(5) Detector is polluted</p> <p>(6) Improper selection of carrier gas flow</p> <p>(7) Improper selection of hydrogen and air(FID)</p> <p>(8) The amplifier is not stable</p> <p>(9) Acquisition board is not good</p>	<p>(5) Clean the detector</p> <p>(6) Adjust the flow rate of the carrier gas properly with carrier gas stable-flow valve, ensure the total pressure of the gas cylinder is between 50kg/cm<sup>2</sup>~150kg/cm<sup>2</sup></p> <p>(7) Adjust hydrogen and air flow properly</p> <p>(8) Check the repair amplifier</p> <p>(9) Disconnect the signal line of the acquisition board, repair the acquisition board</p>
<p>15. Additional peak</p> <p>*The peak width at half height suddenly increases</p>	<p>(1) High component peaks of the previous sample</p> <p>(2) When the column temperature rises, the water or other impurity that condenses in the column is in the peak</p> <p>(3) Air peak</p> <p>(4) Sample decomposition</p> <p>(5) Sample pollution</p> <p>(6) The reaction of the the fixed columns in order to reaction of the sample and the the attached agent</p> <p>(7) Chromatographic stigma glass cotton contamination or syringe contamination</p> <p>(8) Sample silicone rubber contamination or low molecular component slips out</p>	<p>(1) Enter the sample when all the previous samples slipped out</p> <p>(2) Install or regenerate purifier to select appropriate operating conditions</p> <p>(3) Remove the air from the syringe</p> <p>(4) Lower the sampler temperature(do not use fixed liquid or carrier that can be easily decomposed)</p> <p>(5) Ensure that the sample is clean, no impurity is mixed with other components.</p> <p>(6) Use other chromatographic sample with avoid the liquid, the carrier gas or stationary phase</p> <p>(7) Replace the column head glass cotton or clean syringe</p> <p>(8) Bake silicone rubber at 200°C for 16 hours before use</p>

16. Baselines do not return to zero	(1) Zero regulation position is abnormal (2) The excessive loss of the column (FID) (3) Detector pollution Acquisition board failure	(1) Short-circuit the signal with wire, calibrate to zero (2) Using less lost chromatographic columns (3) Clean detector Repair acquisition board
17. There is a spike peak in the irregular distance	(1) Dust particles or exotic substances burn in flames irregularly(FID) (2) Leakage of insulator or high impedance connection relay (3) Amplifier failure  (4) Flame pulsation	(1) Remove the water from the pipe and replace or activate the desiccant in the hydrogen filter  (2) Detect the leakage  (3) Remove impurities in the flow path, if there are impurities in the chromatographic column, raise the column temperature properly (4) Adjust proper hydrogen and air flow
18. There are short spines in equal intervals	(1) Water condenses in hydrogen pipeline  (2) Gas leakage (3) There is a blockage in the flow  (4) Flame pulsation	(1) Remove the water from the pipe and replace or activate the desiccant in the hydrogen filter (2) Detect the leakage (3) Remove impurities in the flow path, if there are impurities in the chromatographic column, raise the column temperature properly (4) Adjust proper hydrogen and air flow
19. Large baseline noise	(1) Chromatographic column contamination or chromatographic column loss is too large (2) Carrier gas contamination (3) Carrier gas flows too fast (4) Carrier gas leakage (5) Grounding is not good (6) High resistance contamination (7) Injector pollution	(1) Change chromatography column  (2) Replace or regenerate carrier gas filter (3) Reregulate gas flow velocity (4) Detect leakage (5) Ensure that the instrument is well grounded (6) Find out the polluted resistance and clean (7) Clean injection tube and



	<p>(8) Hydrogen flows too fast or too slow</p> <p>(9) Air flows too fast or too slow</p> <p>(10) Air or hydrogen contamination</p> <p>(11) Water condenses in FID</p> <p>(12) Detector cable is not well contacted</p> <p>(13) Detector insulation becomes smaller (Ionization detector)</p> <p>(14) Detector electrode, nozzle and bottom pollution</p>	<p>silicon rubber</p> <p>(8) Readjust the hydrogen flow velocity</p> <p>(9) Readjust air flow velocity</p> <p>(10) Change hydrogen, air filter</p> <p>(11) Increase FID temperature to eliminate the water</p> <p>(12) Change or repair the cable</p> <p>(13) Clean the detector</p> <p>(14) Clean the detector</p>
20. Periodic baseline fluctuation	<p>(1) Bad temperature control of detector</p> <p>(2) Improper temperature regulation of chromatographic column oven</p> <p>(3) Improper regulation of carrier gas flow</p> <p>(4) Carrier gas flow pressure is too low</p> <p>(5) Air, hydrogen is not regulated properly(FID)</p>	<p>(1) Check platinum resistance, improve control precision</p> <p>(2) Check platinum resistance, improve control precision</p> <p>(3) Reregulate carrier gas flow velocity</p> <p>(4) Change carrier gas cylinder</p> <p>(5) Reregulate hydrogen, air flow</p>
21. Single direction baseline drift	<p>(1) The temperature of the detector is greatly increased or reduced.</p> <p>(2) Amplifier zero drift</p> <p>(3) A large increase or decrease in the temperature of a column</p> <p>(4) The carrier gas is running out</p>	<p>(1) Keep detector temperature stable. Temperature change after starting up is normal</p> <p>(2) Detect and repair amplifier</p> <p>(3) Keep chromatography column temperature stable. Temperature change after starting up is normal</p> <p>(4) Change carrier gas cylinder</p>
22. Baseline change after program temperature rise	<p>(1) Column loss increases when temperature rises</p> <p>(2) Column flow is not</p>	<p>(1) Choose proper column or age the chromatography column</p> <p>(2) Reregulate column flow</p>

	<p>regulated well</p> <p>(3) Chromatography column pollution</p> <p>(4) 2 columns have different fixed liquid amount</p>	<p>velocity</p> <p>(3) Change column</p> <p>(4) 2 columns should have same fixed liquid amount</p>
<p>23. Irregular baseline change when temperature rises</p>	<p>(1) Column loss is too much</p> <p>(2) Operation condition is not selected correctly</p> <p>(3) Column pollution</p> <p>(4) Ghost peak appears when silicon rubber temperature rises</p>	<p>(1) Choose proper column, column use temperature should be far below fixed liquid highest use temperature</p> <p>(3) Change column</p> <p>(4) Silicon rubber should be baked at 200 °C for 16 hours before use</p>

**Drawell International Technology Limited**  
**Shanghai Drawell Scientific Instrument Co.,Ltd**

**Add** : Suite 1506,Lane581 XiuChuan Rd.,PuDong New Area,Shanghai,China

**Tel**: 0086 21 50966080

**Fax**: 0086 21 50966080

**Web** : [www.drawell.com.cn](http://www.drawell.com.cn)

**Email** : [sales01@drawell.com.cn](mailto:sales01@drawell.com.cn)