

# **LIO Far Infrared Drying Oven**

## **User Manual**



**Drawell International Technology Limited**  
**Chongqing Drawell Instrument Co., Ltd.**  
**Shanghai Drawell Scientific Instrument Co.,Ltd.**

**Chongqing Center** : Suite 2705,Building No.12,Shiyou Road No.1, Yuzhong District,  
Chongqing, China.

**Shanghai Office** : Suite 1117,Lane561 XiuChuan Rd.,PuDong New  
Area,Shanghai,China

**Homepage** : [www.drawell.com.cn](http://www.drawell.com.cn)

**Tel** : 0086-023-63268643

**Email** : [sales05@drawell.com.cn](mailto:sales05@drawell.com.cn)

## 1. General information

The incubator adopts high efficiency, low consumption far-infrared heating technology, which has good effects on fast drying work and sample test. The product is widely used in laboratories of industrial, agricultural, medical and scientific research field. The heating temperature can be freely selected and the radiation performance is not degraded for long-term use, reliable and easy for operation.

## 3: Technical specifications

- 1) Power supply: AC 220V  $\pm$  10%; 50Hz  $\pm$  1%
- 2) Working temperature: Room temperature +10~300°C
- 3) Temperature fluctuation:  $\pm$ 1 °C
- 4)Temperature uniformity:  $\pm$ 3% °C
- 5) Far infrared radiation wavelength: 2.5~6 $\mu$ m
- 6)Spectral emission coefficient: 0.92

## 4. Operation

- 1.Place the sample in the chamber, close the inner glass door and the outer door, open the cover on the top of the incubator in half.
2. Turn on the incubator,in order to shorten the heating time, turn the temp. switch to the second level.

## 5、 1.Panel Instructions

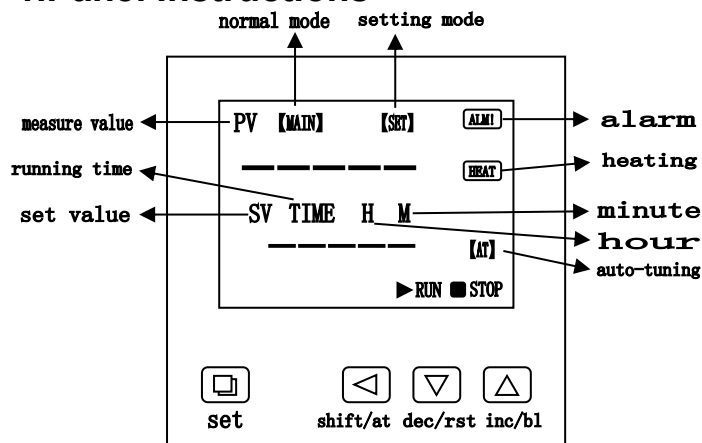

### Definitions of symbols:

1. **【MAIN】**: Only in normal state(not setting mode),this symbol appears
2. **【SET】**: Only in setting mode , this symbol appears
3. **RUN**: This symbol always appear unless the timing program is over.
4. **STOP**: This symbol appears to show you timing program is over.
5. **【AT】**: This symbol twinkles only when you start an Auto-tuning procedure
6. **ALM!**: This symbol appears to show you over-temperature alarm
7. **HEAT**: This symbol appears or twinkles to show you the heater is working.

## 2. Operation and using

- 1) When the controller is switched on, display windows show the version number and the value of temperature range for 3 seconds, then it starts running.
- 2) “◀” button: In the setting state, click on the button to shift the set value.
- 3) “▼” button: In the setting state, click on the button to reduce the set value. If you keep pressing on the button, the set value will reduce continuously.
- 4) “▲” button: In the setting status, click on the button to increase the set value. If you keep pressing on the button, the set value will increase continuously. In the Normal status, click on the button to open or close the backlight lamp.
- 5) In the setting mode, If no button is pressed within 60s, the controller will automatically return to normal display.
- 6) Temperature and time setting
  - No timing function

Press the “SET” button in the non-set state, windows display the prompt “SP” and temperature set value. Using the “SHIFT”、”DEC” and “inc” buttons, user can modify the settings to the desired value, then press the “SET” button again, controller will return to the normal display, the setting value will be saved automatically.
  - With timing function

Press the “SET” button in the non-set state, windows display the prompt “SP” and temperature set value. Re-press the “SET” button, windows display the prompt “ST” and time set value. Press the “SET” button again, controller will return to the normal display, the setting value will be saved automatically.

When the time is set to “0”, it indicates the timer is inoperative, the controller will run continuously. If there is time set, the under window of controller will display temperature setting value or the running time according to the value of “ndt” in Parameters table 2. When display the running time, the unit decimal point is lit, Start timing when the measured temperature reaches to the setting value, When the runtime is over, the under window of controller will display “End”, the buzzer will sound for 60s, it can be muted by pressing any button, press the “RST” button for 3s at this time, the controller will restart.
- 7) When Over-temperature alarm, the buzzer beeps continuously, "ALM" warning light is lit.
- 8) When the buzzer sounds, press any key to mute.
- 9) If the controller upper display window displays “----”, said temperature sensor or the controller itself fails, please carefully check the temperature sensor and wiring.

## 3. Auto-tuning of PID

Use auto-tuning function when the temperature control is not good.

In the non-set state, press the “AT” button for 6s, the window displays ‘AT’ and ‘oFF’, change ‘oFF’ to ‘oN’ by ‘Inc’ or ‘Dec’ button, then the controller will run the auto-tuning program, the “AT” symbol flashes, after auto-tuning end, the light stops flashing, parameter value is saved automatically. In the auto-tuning process, press the

“AT” button for another 6s, the controller will stop the auto-tuning program.

In the auto-tuning process, the “SET” button is invalid, the under window always displays temperature set value.

**Action please:** the temperature is not precisely controlled when you start an auto-tuning program, there must be over-temp situation, please take out your stuffs from the oven before auto-tuning.

#### 4. Internal parameters settings

In the non-set state, Press the “Set” button for 3s, controller will display the password prompt “Lc”. Adjust the password to the required value, then press the “Set” button again, it will run into the internal parameter setting state. If press the “Set” button for another 3s, it will return to the running state, the setting value will be saved automatically.

**Parameter table 1**

Parameter prompt	Name	Instruction of the function	(Setting range) factory set value
<b>Lc-</b>	Password key	When Lc=3, enter the next parameters.	0
<b>ALH-</b>	Over-temp alarm	If “SV>(SP+ALH)”, the “ALM” light turns on. The buzzer sounds and the heating output turns off.	(0~ 100.0℃) 20.0
<b>ALL-</b>	Under-temp alarm	If “SV<(SP-ALL)”, the “ALM” light flashes, the buzzer sounds.	(0~ 100.0℃)
<b>P-</b>	Proportional band	Adjustment of proportional function.	(1~ 400.0℃) 50.0
<b>I-</b>	Integration time	Adjustment of integration function.	(1~2000S) 700
<b>d-</b>	Differential time	Adjustment of differential function.	(0~1000S) 350
<b>T-</b>	Control cycle	The temperature control cycle.	(1~60S) 5
<b>Pb-</b>	Zero point adjust	When the zero error comparatively larger, to update this value should be needed. Pb= actual value – measure value	(-12.0~ 12.0℃) 0
<b>PL-</b>	Full point adjust	When the full point error also comparatively larger, to update this value should be needed. PK=1000×(actual value – measure value) / measure value.	(-999~ 999) 0
<b>Addr</b>	Address	The communication address. invalid	(1~32) 1

<b>Loc</b>	Setting lock	0:you are allowed to alter the set value of temperature and time; 1:the set value of temperature or time is not allowed to alter	0(0~1)
------------	--------------	---	--------

**Parameter table 2**

<b>Parameter prompt</b>	<b>Name</b>	<b>Instruction of the function</b>	<b>(Setting range) factory set value</b>
<b>Lc-</b>	Password key	When Lc=9, enter the next parameters.	0
<b>ndA-</b>	Temp alarm mode	0: With over-temp alarm only. 1: With over-temp alarm and under-temp alarm at the same time.	(0~1) 0
<b>ndt-</b>	Timer mode	0: No timer function. 1: The timer get to work as soon as the set temperature value is achieved.. 2: The timer start to work as soon as the instrument get to work.	(0~2) 1
<b>Hn-</b>	Timer unit	0: Minute. 1: Hour.	(0~1) 0
<b>SPD</b>	Timer parameter	When measured value of temperature >SPD+set value of temperature,timer get to work	(0.1~100.0℃) 0.5
<b>SPT</b>	Constant temperature tip time	In timing mode(set value of temperature is achieved),the buzzer reminds you when the tip time you've set is achieved.	(0~9999S) 0
<b>EST</b>	Tip after timing	When timing program is over,the buzzer reminds you as soon as the tip time you've set is achieved	(0~9999S) 0
<b>EH-</b>	Timer end mode	0: Continue to maintain the constant temperature when the running time is over. 1: Stop the temperature control when the running time is over.	(0~1) 0
<b>ndo-</b>	Switch-output	0: when timing program is over 1: when over-temperature alarm occurs	(0~2) 0
<b>SPL-</b>	Minimum set point	The minimum temperature set point.	(-50.0~50.0)
<b>SPH-</b>	Maximum set point	The maximum temperature set point.	(0~400.0) 300.0

**Parameter table 3**

Parameter prompt	Name	Instruction of the function	(Setting range) factory set value
<b>Lc-</b>	Password key	When Lc=27, enter the next parameters.	0
<b>FC</b>	Temperature unit	0:Centigrade 1:Fahrenheit	(0~1)0

**5、Wiring**

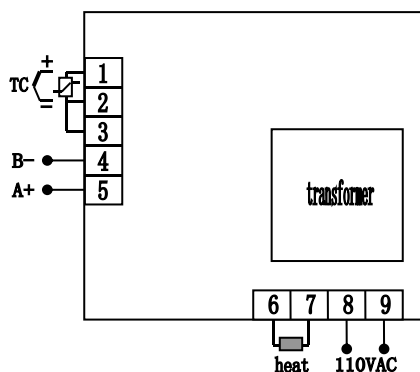

**1. PCD-C6000**

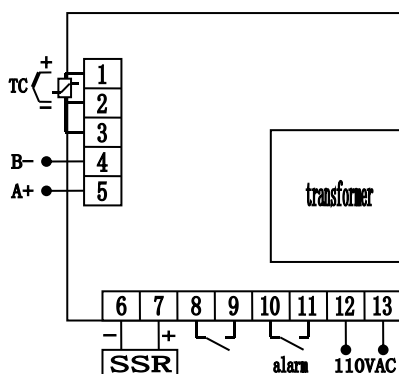

**2. PCD-C6001**

**6、List of specifications**

Model	DW-LIO-300	DW-LIO-400	DW-LIO-500	DW-LIO-600
Packing size(cm)	64×50×60	73×53×69	78×69×80	88×73×95
Chamber size(cm)	35×35×35	45×40×45	50×50×55	60×60×70
shelf (块)	2	2	3	3
Input Power w	1400	2000	2800	4000
attaching plug A	10	10	15	25
NW/GW (Kg)	36/56	51/81	76/111	111/151

## 7、Electrical diagram

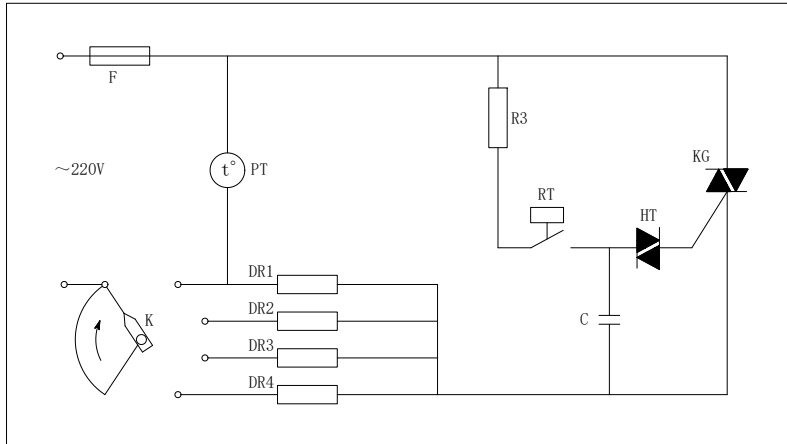

- K: Temp. Switch                      KG: Two-way thyristor
- PT: Temp. controller                F: Fuse tube
- HT: Two-way trigger.                DR1-DR4 :Heater
- R3: Resistor                            C: Capacitor

## 8、Matters needing attention :

1. The drying oven shell must be effective grounding, to ensure the safety in use.
2. The drying oven should be placed in good indoor ventilation, around its do not place flammable items.
3. The drying oven no explosion-proof device, and may not be in the inflammable and explosive goods and dry.
4. Items placed in the not too crowded, especially surrounding the temperature sensor, must make room, hot air circulation.
5. Box should be always kept clean inside and outside, not for a long time should be set good plastic dust cover, put in the dry room.
6. Use of the abnormal phenomenon, please cut off the power supply and promptly get in touch with our company!

## 9、 Fault handling:

phenomenon	principle	Deal
No resource	No power supply socket	Replace the socket
	Good is not plugged in or disconnected	Insert the plug or good pick up line
	Fuse open	Change the fuse
	The power switch is not closed	Close the power switch
The temperature in the cabinet does not rise	Set temperature low	Adjust the set temperature
	Electric heater is bad	In electric heater
	Temperature controller is bad	Change the temperature controller
	The temperature sensor cable is loose	Tighten the sensor connecting nut
The great error in the set temperature and the temperature in the cabinet	Temperature sensor is bad	In the temperature sensor
Temperature is out of control	Temperature sensor is fixed	Fixed temperature sensor
	Temperature controller is bad, silicon controlled rectifier	In the temperature sensor, silicon controlled rectifier

## 10、 After-sales service

Our company guarantees the incubator (repair, replacement or return), warranty period is one year (in addition to the heating element). Warranty for damage occurred all non-artificial factors or doesn't work, our company is responsible for free repair or replacement parts; After a year in line with the spirit of service to users, try our best to provide convenience for the user.

## Packing list

Item No.	Description	Category	Unit	Qty.	Remarks
1	Far Infrared Fast Drying Oven	Main body	pc	1	
3	This manual	Document	Copy	1	
4	Warranty	Document	Copy	1	



5	Quality certificate	Document	Copy	1	
6	Packing list	Document	Copy	1	
7	fuse	Spare parts	pc	1	

The items listed in the packing list are in accordance with the actual parts packed in the carton..

Packing & QC:

**Drawell International Technology Limited**



**Chongqing Drawell Instrument CO.,Ltd**

Add: Suite 2705, Building No. 12, Shiyou Road No. 1, Yuzhong District,  
Chongqing, China  
Tel: 0086-023-63268643

**Shanghai Drawell Scientific Instrument Co.,Ltd**

Add : Suite 1117, Lane 561 XiuChuan Rd., PuDong New Area, Shanghai, China

Web : [www.drawell.com.cn](http://www.drawell.com.cn)  
Email : [sales05@drawell.com.cn](mailto:sales05@drawell.com.cn)